

Part number:

13.0 Through Drives

Pump Frame Size (K3VL cc/rev)		45,60,80,112,140,200			80,112,140,200			112,140,200	200	
		28								
Mounting Code		A	B	BB	C4	C	CC	D	E	
Dimensions [in (mm)]	Pilot Diameter	3.25 (82.55)	4.000 (101.60)		5.000 (127.0)			6.000 (152.4)	6.50 (165.1)	
	Pilot Depth	0.315 (8.0)	0.433 (11.0)		0.551 (14.0)			0.551 (14.0)	0.710 (18)	
	Mounting Bolt Hole Thread	M10 - 1.5	M12 - 1.75		M12 - 1.75	M16 - 2.0		M20 - 2.5		
	Shaft Length	1.358 (34.5)	1.929 (46.0)		2.185 (55.5)			2.756 (70.0)		
	Spline Engagement	0.984 (25.0)	1.535 (39.0)		1.772 (45.0)			2.480 (63.0)		
Shaft Spline Detail [in (mm)]	Standard	SAE Flat Root Side Fit - Tolerance Class 5								
	Number of Teeth	9	13	15	14	17	13			
	Diametral Pitch	16/32			12/24			8/16		
	Pressure Angle	30°								
	Major Diameter	0.625 (15.875)	0.875 (22.225)	1.000 (25.4)	1.283 (32.588)	1.533 (38.938)	1.850 (46.990)			
	Internal Diameter Over Pins	0.397 (10.089)	0.653 (16.589)	0.780 (19.807)	0.961 (24.407)	1.207 (30.648)	1.301 (33.056)			
	Pin Diameter	0.108 (2.743)			0.144 (3.658)			0.216 (5.486)		
Allowable Torque [lbf-ft (Nm)]		45 (31)	150 (203)	166 (226)	295 (400)	412 (559)	516 (699)			

Kit Detail

SAE A Kit (K3VL 28-140)

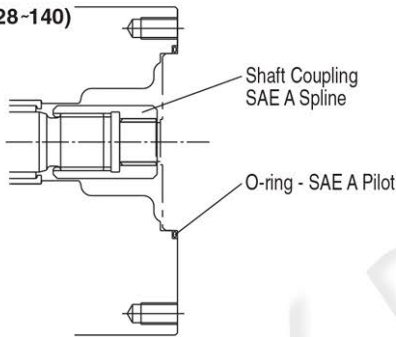

SAE B-D Kits (K3VL 28-140)

SAE A-E Kits (K3VL 200)

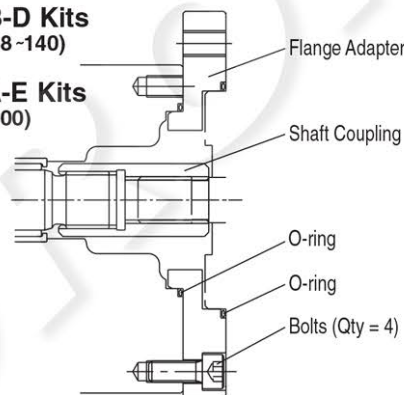

CAUTION: Second pump should have solid pilot so o-ring can seal against the corner.

Bending Moment Limitation

	Symbol	Units	K3VL28	K3VL45/60	K3VL80	K3VL112/140	K3VL200
Maximum Allowable Bending Moment	B _{max}	lbf-ft (Nm)	81 (110)	101 (137)	180 (244)	341 (462)	685 (930)
Pump Weight Without Through Drive	M	lb (kg)	44 (20)	55 (25)	77 (35)	143 (65)	209 (95)
Pump Weight With SAE A Through Drive	M _a	lb (kg)	44 (20)	62 (28)	84 (38)	152 (69)	226 (103)
Pump Weight With SAE B/BB Through Drive	M _b	lb (kg)	48 (22)	73 (33)	97 (44)	167 (76)	249 (113)
Pump Weight With SAE C/CC Through Drive	M _c	lb (kg)	-	-	99 (45)	172 (78)	249 (113)
Pump Weight With SAE D Through Drive	M _d	lb (kg)	-	-	-	183 (83)	253 (115)
Pump Weight With SAE E Through Drive	M _e	lb (kg)	-	-	-	-	264 (120)
Distance from Mounting Face to Pump Center of Gravity Not Including Through Drive Kit	d ₂	in (mm)	4.33 (110)	4.72 (120)	5.12 (130)	5.91 (150)	7.48 (190)
Distance from Mounting Face to Pump Center of Gravity Including Through Drive Kit (Approximation)	d ₁	in (mm)	4.72 (120)	5.12 (130)	5.71 (145)	6.89 (175)	8.47 (215)
Through Drive Pump Length from Front to Rear Mounting Flanges	D#	in (mm)	Page 19	See Page 30 With through drive pump length			Page 31

K3VL45 – 140 Through Drive Installation Details

SAE A SAE A 2 hole
SAE J744-82-2

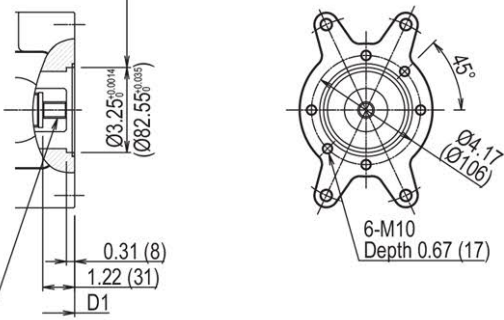

SAE A 30° Involute Spline
SAE J744-16-4 9T 16/32DP

SAE B SAE B 2 hole
SAE J744-101-2

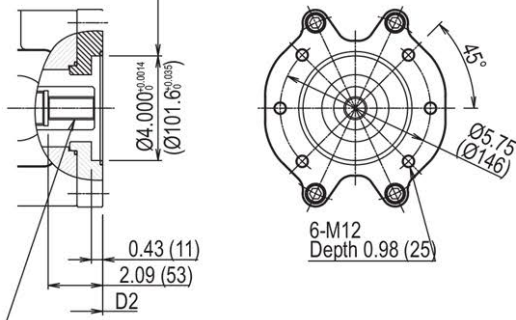

SAE B 30° Involute Spline
SAE J744-22-4 13T 16/32DP

SAE B-B SAE BB 2 hole
SAE J744-101-2

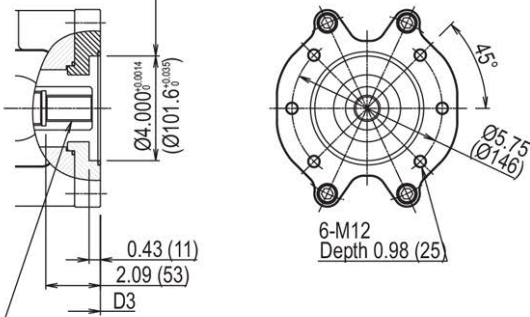

SAE BB 30° Involute Spline
SAE J744-25-4 15T 16/32DP

SAE C SAE C 2 hole
SAE J744-127-2

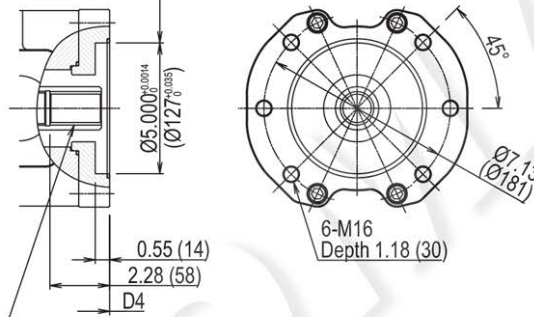

SAE C 30° Involute Spline
SAE J744-33-4 14T 12/24DP

SAE C 4 hole
4.500^{+0.007}
(114.5^{+0.20})

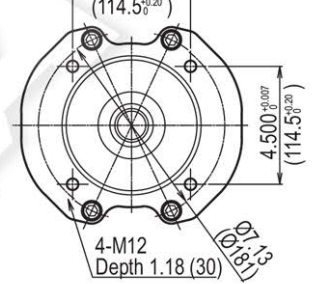

SAE C-C SAE CC 2 hole
SAE J744-127-2

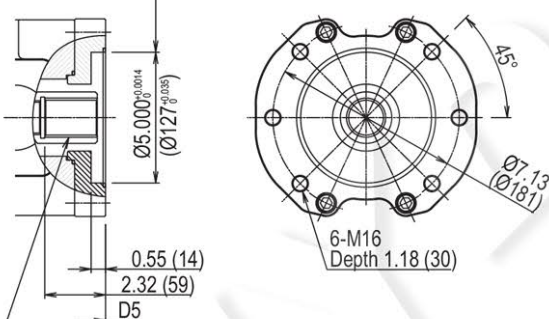

SAE CC 30° Involute Spline
SAE J744-38-4 17T 12/24DP

SAE CC 4 hole
4.500^{+0.007}
(114.5^{+0.20})

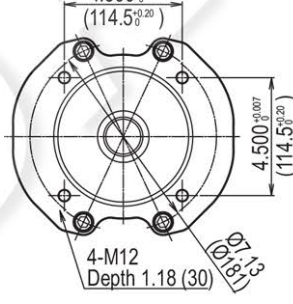

SAE D SAE D 4 hole
SAE J744-152-2

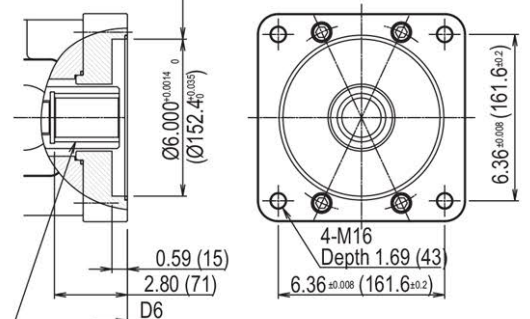

SAE D 30° Involute Spline
SAE J744-47-4 13T 8/16DP

Through Drive Pump Length From Front to Rear Mounting Flanges

Note	Interface	Units	K3VL45/60	K3VL80	K3VL112/140	K3VL200
D1	SAE A	in (mm)	9.61 (244.0)	10.71 (272.0)	12.11 (307.5)	14.37 (365)
D2	SAE B		10.39 (264.0)	11.50 (292.0)	13.09 (332.0)	15.12 (384)
D3	SAE B-B		-	11.50 (292.0)	13.09 (332.0)	15.12 (384)
D4	SAE C		-	11.67 (296.5)	13.29 (337.5)	15.12 (384)
D5	SAE C-C		-	-	13.29 (337.5)	15.12 (384)
D6	SAE C-4		-	-	-	15.12 (384)
D7	SAE D		-	-	13.80 (350.5)	15.63 (397)
D8	SAE E		-	-	-	15.63 (397)

WARNING: Do not attempt to use UNC threaded bolts in METRIC bolt holes.