

Part number:

HYDROMA

HYDRAULICKÉ SYSTÉMY

**HIDROMA
SYSTEMS**

UKŁADY HYDRAULICZNE

HYDROMA

ГИДРАВЛИЧЕСКИЕ СИСТЕМЫ

411 series

Axial Piston
Fixed displacement pump
Bent axis design

Technical Catalogue

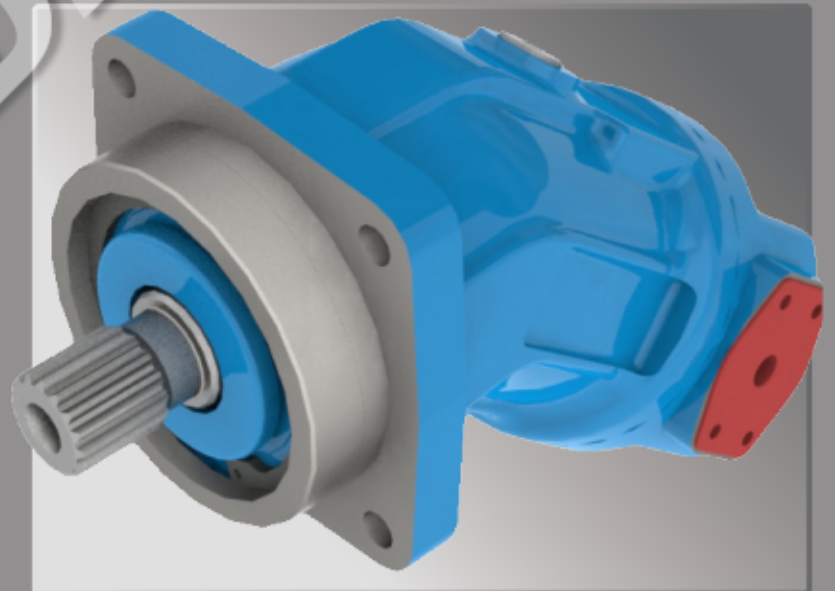

Contents

General information.....	2
Ordering Code.....	3
Standard program.....	3
Technical characteristics.....	4
Requirements for working fluids.....	4
Pump nominal size range determination.....	4
Allowed radial and axial loads on shaft.....	5
The scheme for choosing the optimum angle of gear and V-belt drives adjustment.....	5
Overall-mounting dimensions. Size 56 cc/rev.....	6
Overall-mounting dimensions. Size 107 cc/rev.....	7
Recommendations for mounting.....	8

General information.

The pumps of 411 series is the product of worldwide application, designed for the world market as per international standards.

The pumps convey the mechanical energy of the shaft rotation into the working fluid energy. Hydraulic pump flow is proportional to shaft rotation frequency and to working displacement.

Fixed displacement axial-piston bent-axis pumps are intended for application in mobile and stationary units.

411 series pumps have the following displacements:

- 56 cc/rev
- 107 cc/rev

Max working pressure - 40 MPa
Peak pressure - 45 MPa

Connection:
mounting flanges - ISO 3019/2, 4 bolts

high pressure hoses connection flanges - SAE 3000psi
- SAE 6000psi

drain lines ports - M18x1,5-12 DIN 9974-1 / ISO 3852-1

spline shafts - as per GOST 6033-80
- as per DIN 5480

key shafts - as per DIN 6885

Ordering Code

A	B	C	D	E	F	G	H	I
4	1	1

● = standart
 ○ = optional
 - = not available

A - series

code	description
411	series 411

B - product version

code	description	411.0.56	411.0.107
0	basic	●	●

C - displacement

code	description	411.0.56	411.0.107
56	56 cm ³	●	-
107	107 cm ³	-	●

D - rotation

code	description	411.0.56	411.0.107
L	left	●	●
R	right	●	●

E - shaft end

code	description	411.0.56	411.0.107
A1	splined shaft W30x2x30x14x9g DIN5480	●	-
A2	splined shaft W35x2x30x16x9g DIN5480	●	-
A3	splined shaft W40x2x30x18x9g DIN5480	-	●
A4	splined shaft W45x2x30x21x9g DIN5480	-	●
A5	splined shaft 35xf7x2x9g GOST6033-80	●	-
A6	splined shaft 45xh8x2x9g GOST 6033-80	-	●
Z1	parallel shaft with key Ø30k6 8x7x50 DIN 6885	●	-
Z2	parallel shaft with key Ø40k6 12x8x63 DIN 6885	-	●
Z3	parallel shaft with key Ø35k6 AS10x8x50 DIN 6885	●	-
Z4	parallel shaft with key Ø45k6 AS14x9x63 DIN 6885	-	●

F - end cap ports and options

code	description	411.0.56	411.0.107
F	4 0 1 flange at side, 1 flange at rear	●	●
	↓		
	↓		
	valves		
	0 none		
	system ports (high pressure)		
	4 1 flange at side, 1 flange at rear		

G - special features

code	description	411.0.56	411.0.107
NN	none	●	●

H - shaft seals

code	description	411.0.56	411.0.107
B	NBR	●	●
F	FKM	●	●

I - climatic versions and category of desposition

code	description	411.0.56	411.0.107
Y1	temperate climate, placing on open air	●	●
TB1	tropical climate, placing on open air	●	●

Standard program.

411.0.56.R.A1.F40.NN	411.0.107.R.A3.F40.NN
411.0.56.R.A2.F40.NN	411.0.107.R.A4.F40.NN
411.0.56.R.A5.F40.NN	411.0.107.R.A6.F40.NN
411.0.56.R.Z1.F40.NN	411.0.107.R.Z2.F40.NN
411.0.56.R.Z3.F40.NN	411.0.107.R.Z4.F40.NN
411.0.56.L.A1.F40.NN	411.0.107.L.A3.F40.NN
411.0.56.L.A2.F40.NN	411.0.107.L.A4.F40.NN
411.0.56.L.A5.F40.NN	411.0.107.L.A6.F40.NN
411.0.56.L.Z1.F40.NN	411.0.107.L.Z2.F40.NN
411.0.56.L.Z3.F40.NN	411.0.107.L.Z4.F40.NN

Technical characteristics.

Size	411.0.56	411.0.107
Displacement V_g , cc/rev	56	107
Speed n , rev/min		
- minimal n_{min}	500	400
- nominal n_{nom}	1500	1200
- maximum n_{max} at inlet pressure 0,8bar	2000	1600
- peak n_{peak} at inlet pressure 2bar	3750	3000
Flow Q , l/min		
- minimal Q_{min}	28.0	42.8
- nominal Q_{nom}	84.0	128.4
- maximum Q_{max}	112.0	171.2
- peak Q_{peak}	210.0	321.0
Pressure (difference) ΔP , bar		
- nominal ΔP_{nom}	250	250
- maximum working ΔP_{max}	400	400
- peak ΔP_{peak}	450	450
Drain pressure P_{dr} , bar		
- maximum working	2.5	2.5
- maximum shorttime (t<5 min)	5	5
Power N , kW		
- nominal N_{nom} (at $n_{nom}, V_{g,nom}, P_{nom}$)	65.3	99.8
- maximum N_{max} (at $n_{max}, V_{g,max}, P_{max}$)	74.7	114.1
- peak N_{peak} (at $n_{peak}, V_{g,peak}, P_{peak}$)	84.0	128.4
Torque T , Nm		
- nominal T_{nom} (at $V_{g,nom}, P_{nom}$)	311.9	596.0
- maximum T_{max} (at $V_{g,max}, P_{max}$)	356.5	681.2
- peak T_{peak} (at $V_{g,peak}, P_{peak}$)	401.1	766.3
Volumetric efficiency	0.95	0.95
Weight, kg	17	29

Requirements for working fluids

Working fluid temperature:

max constant in hydraulic tank
 max peak (output from drain hole)
 min short term (at cold launch)

+85°C
 +100°C
 -40°C

Working fluid cinematic viscosity:

optimal (constant)
 max starting
 min short term

20-35 mm²/s (cS)
 1500 mm²/s (cS)
 10 mm²/s (cS)

Working fluid fineness:

not worse than class 12 as per GOST 17216-71
 not worse than class 18/15 as per ISO/DIN 4406

Pump nominal size range determination

$$\text{Flow } Q = \frac{V_g \cdot n \cdot \eta_v}{1000} \quad \text{l/min}$$

$$\text{Torque } T = \frac{V_g \cdot \Delta P}{20 \cdot \pi \cdot \eta_{mh}} \quad \text{N}\cdot\text{m}$$

$$\text{Power } N = \frac{Q \cdot \Delta P}{600 \cdot \eta_t} \quad \text{kW}$$

where:

 Q – pump flow, l/min T – torque, N·m N – power, kW V_g – pump working displacement, cc/rev n – shaft rotation frequency, rev/min ΔP – pressure difference, bar η_v – volumetric coefficient of efficiency η_{mh} – hydraulic mechanical coefficient of efficiency $\eta_t = \eta_v \cdot \eta_{mh}$ – coefficient of full efficiency

Allowed radial and axial loads on shaft

Pump bearing unit operation lifetime directly depends on the forces acting on output shaft from outside. In order to avoid soon failure of the pumps, the restrictions for external forces on output shaft of the pump should be observed during the project operations.

Values of limiting loads on shaft are given in the Table:

Показатели	Displacement	
	56	107
A, mm	18	20
F_{max} , N	9200	13600
F/P, N/bar	204	302
$\pm F_{ax,max}$, N	800	1250
$\pm F_{ax,max}/P$, N/bar	87	129

The scheme of acting forces is given on the Fig.:

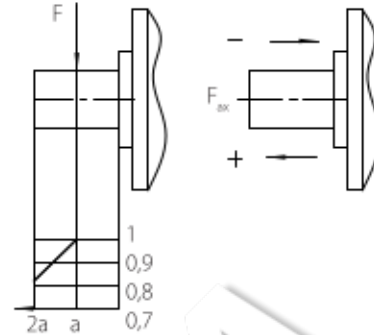

- A - the distance of applied force F from shaft collar
- F_{max} - max radial load at optimum angle of gear mounting
- F/P - radial load acting at pressure P (additional load allowed at pressure P)
- $\pm F_{ax,max}$ - standstill max allowed axial load
- $\pm F_{ax,max}/P$ - max allowed axial load at operation with pressure P

The direction of max allowed axial load should be taken into consideration:

- $F_{ax,max}$ - bearing lifetime increasing
- + $F_{ax,max}$ - bearing lifetime decreasing (should be avoided if possible)

The values of limiting loads on pump shaft are given for optimum angles of gear and V-belt drives adjustment.

The scheme for choosing the optimum angle of gear and V-belt drives adjustment.

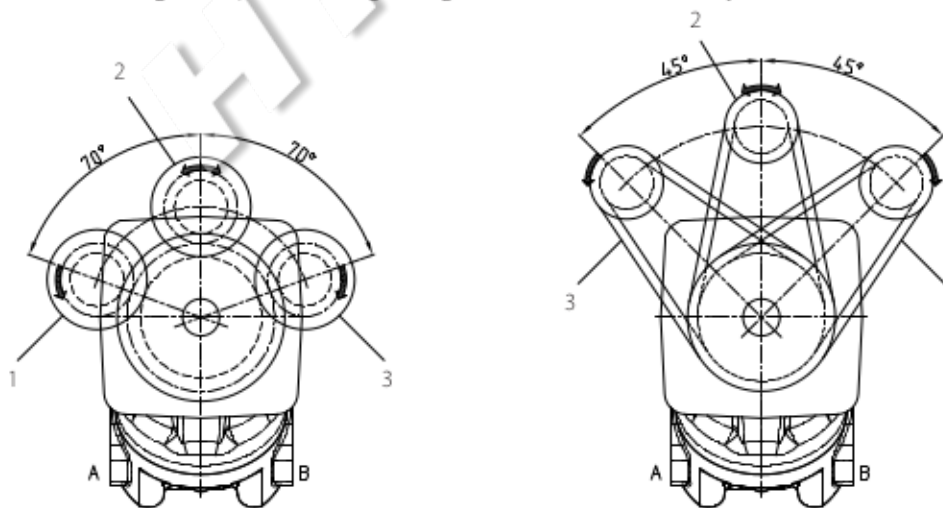

- 1 - for clockwise rotation pump drive (outlet B under pressure)
- 2 - for reverse drive
- 3 - for counterclockwise rotation pump drive (outlet A under pressure)

Choosing other angle of drive adjustment should be negotiated with the manufacturer.

Overall-mounting dimensions. Size 56 cc/rev.

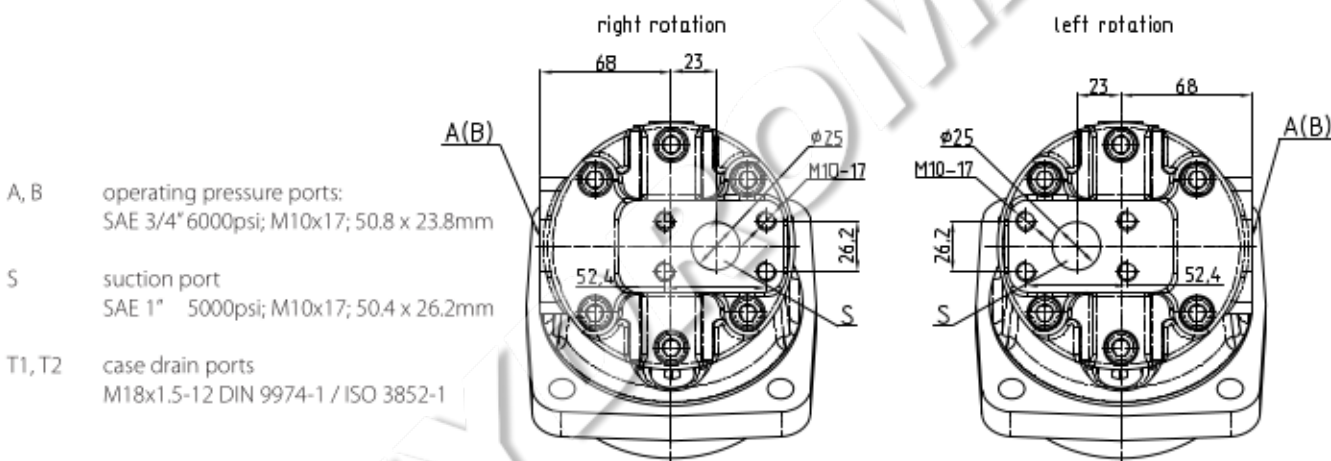
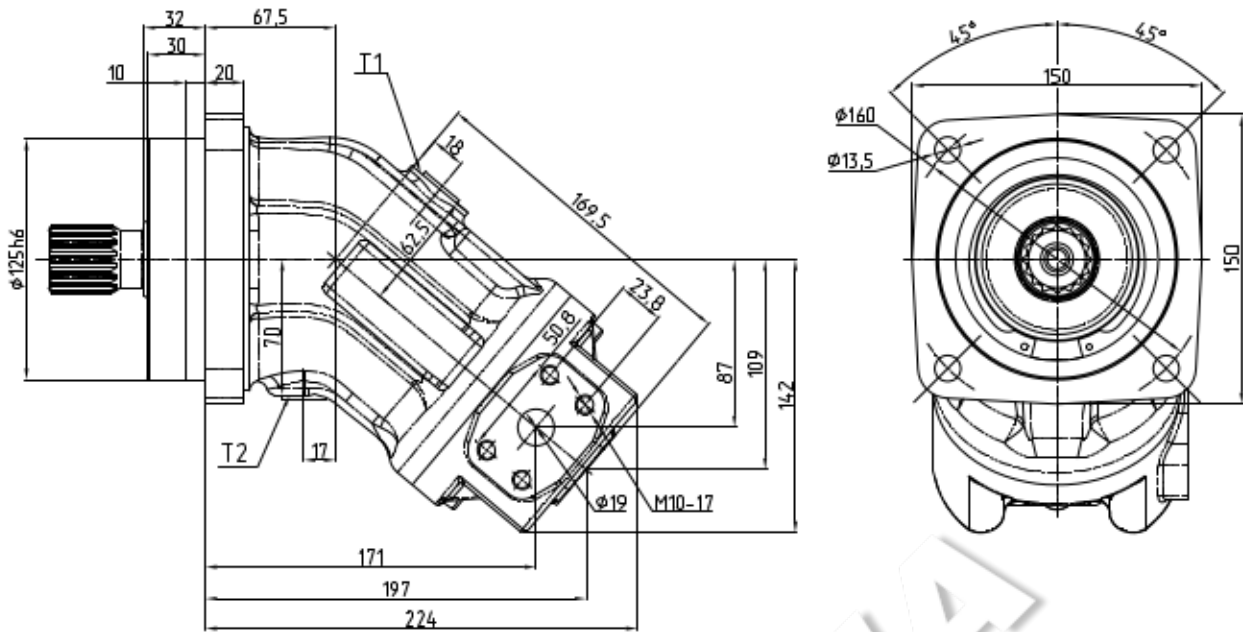

- A, B operating pressure ports:
SAE 3/4" 6000psi; M10x17; 50.8 x 23.8mm
- S suction port
SAE 1" 5000psi; M10x17; 50.4 x 26.2mm
- T1, T2 case drain ports
M18x1.5-12 DIN 9974-1 / ISO 3852-1

Shaft ends

Splined shaft
W30x2x30x14x9g DIN 5480

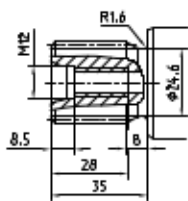

Splined shaft
W35x2x30x16x9g DIN 5480

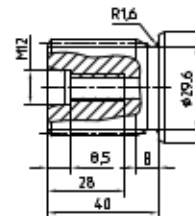

Splined shaft
35x7x2x9g GOST 6033-80

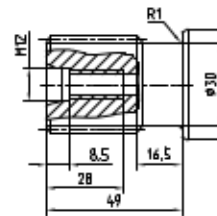

Parallel shaft with key
A 8x7x50 DIN 6885

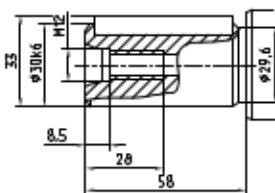

Parallel shaft with key
A 10x8x50 DIN 6885

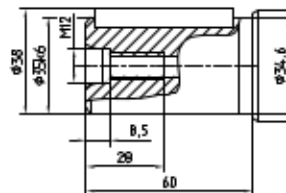

Overall-mounting dimensions. Size 107 cc/rev.

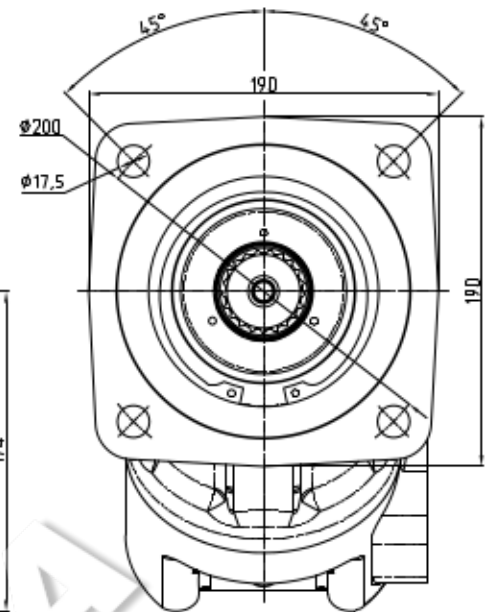
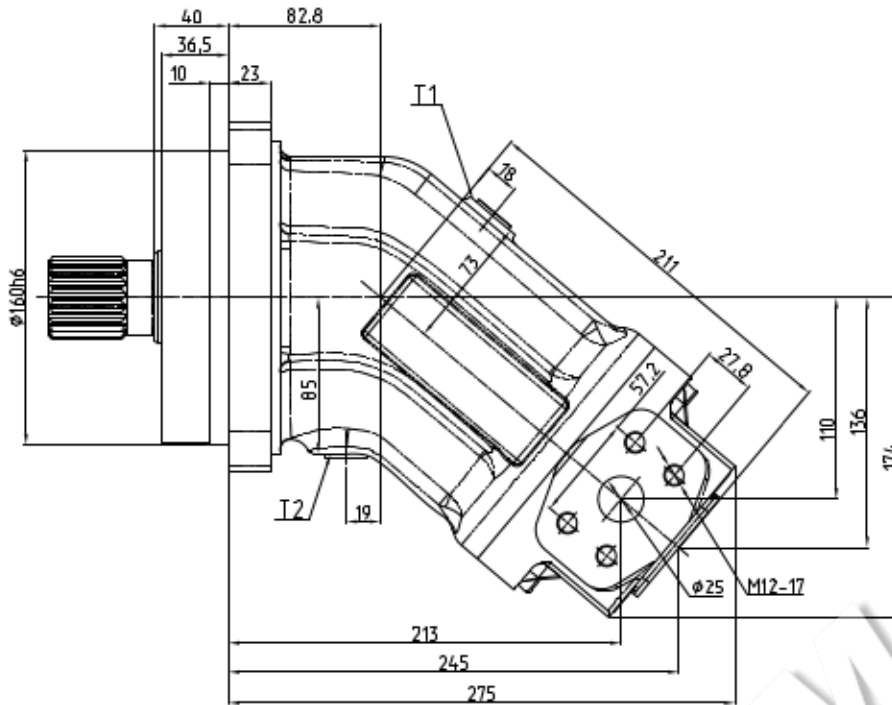

- A, B operating pressure ports:
SAE 1" 6000psi; M12x17; 57.2 x 27.8mm
- S suction port
SAE 1 1/2" 3000psi; M12x20; 69.9 x 35.7mm
- T1, T2 case drain ports
M18x1.5-12 DIN 9974-1 / ISO 3852-1

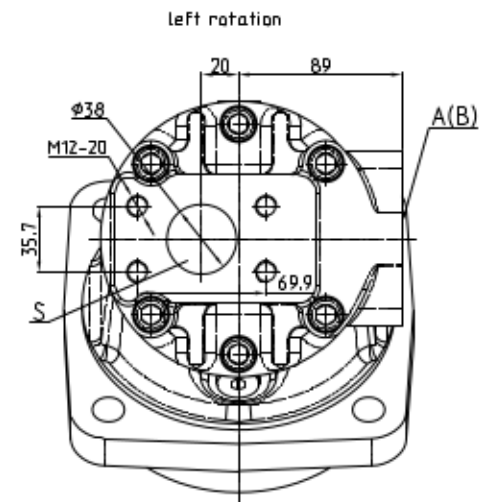
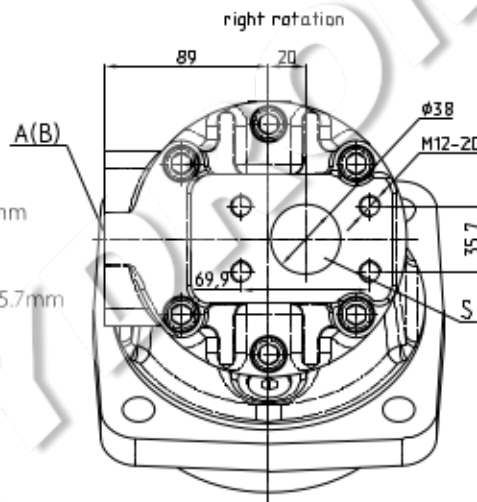

Shaft ends.

Splined shaft
W40x2x30x18x9g DIN 5480

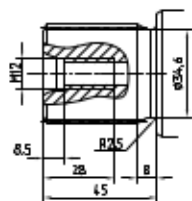

Parallel shaft with key
A 12x8x63 DIN 6885

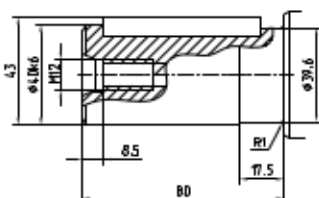

Splined shaft
W45x2x30x21x9g DIN 5480

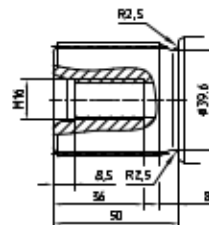

Parallel shaft with key
A 14x9x63 DIN 6885

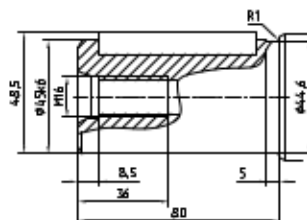

Splined shaft
45xh8x2x9g GOST 6033-80

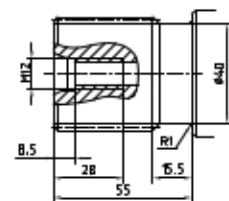

Recommendations for mounting

For 411 series pumps proper operation the requirements of the present section should be met.

Any mounting direction of the pumps is allowed.

Pump drain chamber should always be filled with working fluid. Drain line and sucking line are recommended to be set according to the schemes given on the fig.

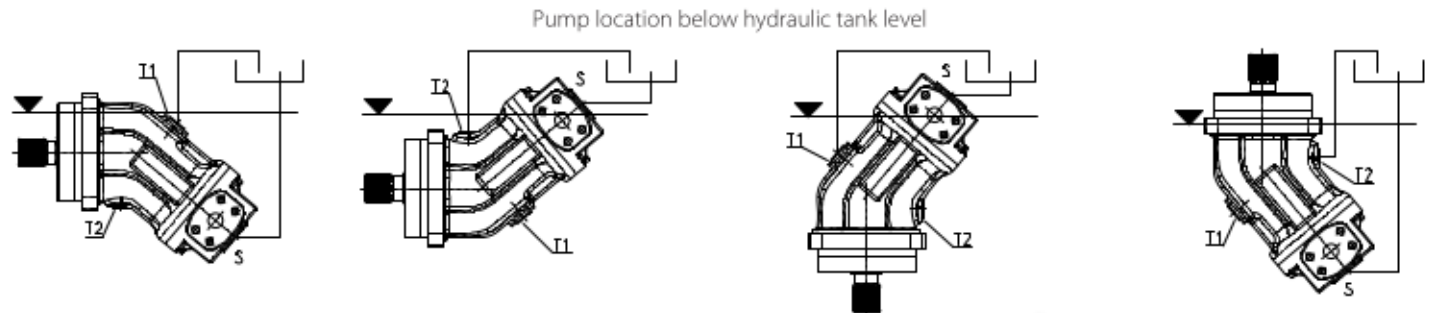

Before the first pump commissioning it is necessary to:

- fill the pump drain chamber with working fluid, for this purpose the air should be output through the top of drain hole;
- fill the sucking line with working fluid;
- perform the first launch at min rotations in order to fill the hydraulic system with working fluid.

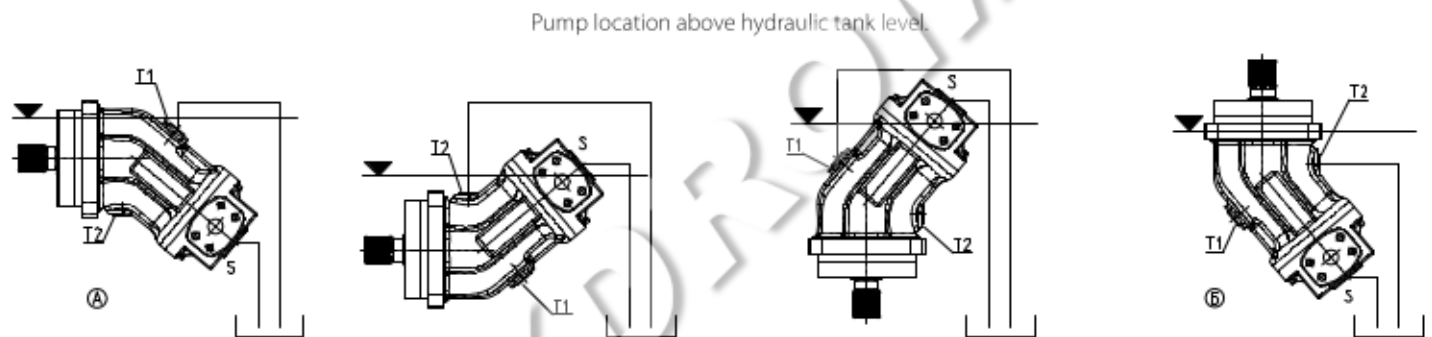

Before the first pump commissioning it is necessary to:

- fill the pump drain chamber with working fluid through the top of drain hole;
- fill the sucking line with working fluid;
- perform the first launch at min rotations in order to fill the hydraulic system with working fluid
- perform the drain chamber filling during each launch; in cases A and B the working fluid outflow from housing into hydraulic tank is possible when the pump is turned off.

Other direction of the pumps is possible after negotiation with the manufacturer.