

Part number:

HYDROMA

HYDRAULICKÉ SYSTÉMY

**HIDROMA
SYSTEMS**

UKŁADY HYDRAULICZNE

HYDROMA

ГИДРАВЛИЧЕСКИЕ СИСТЕМЫ

Tipo / Type

FPMB-*.*

Sez./Section

L

Pag./Page

070/1

Valvola regolatrice di flusso bidirezionale, tipo a manicotto
Needle valve, barrel type

Rev.01-2010/02

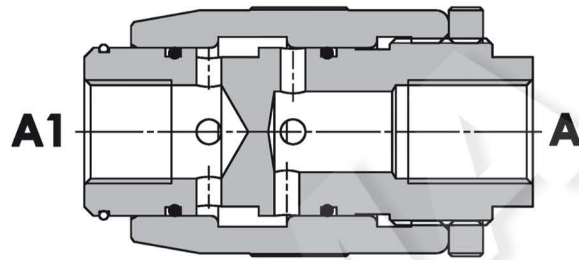
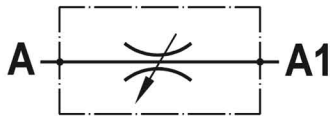

SPECIFICHE TECNICHE

Materiali: corpo e parti interne in acciaio. La superficie esterna è protetta mediante zincatura.

Portata max.: fino a 150 l/min

Pressione max.: 350 bar, vedasi tabella a parte

TECHNICAL SPECIFICATIONS

Materials: body and internal parts are steel made. External surface zinc plated.

Rated flow: up to 150 l/min

Max. pressure: 350 bar, see data sheet

DIAGRAMMA PERDITE DI CARICO - PRESSURE DROP CURVES

Viscosità olio 24 mm²/sec. (3,5 °E)
Temperatura 50 °C

Oil viscosity 24 mm²/sec. (3,5 °E)
Temperature 50 °C

STROZZATORE TUTTO APERTO - FULLY OPEN THROTTLE

A1 → A

A → A1

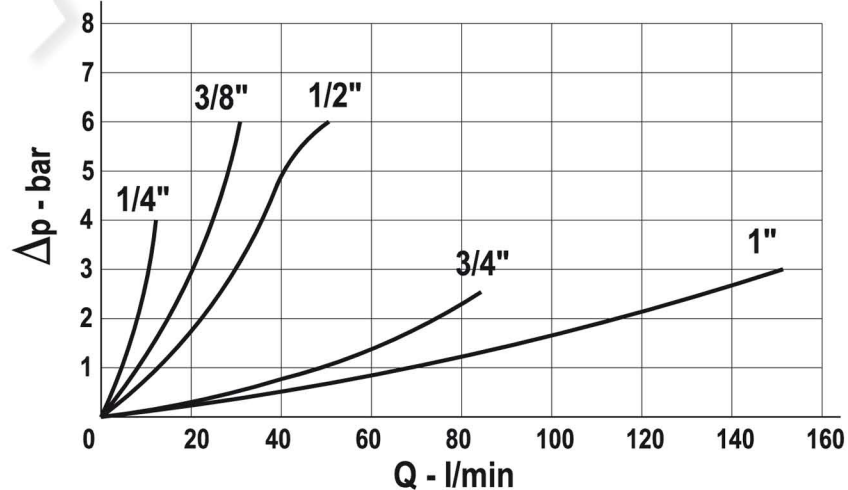

Valvola regolatrice di flusso bidirezionale, tipo a manicotto
Needle valve, barrel type

Rev.01-2010/02

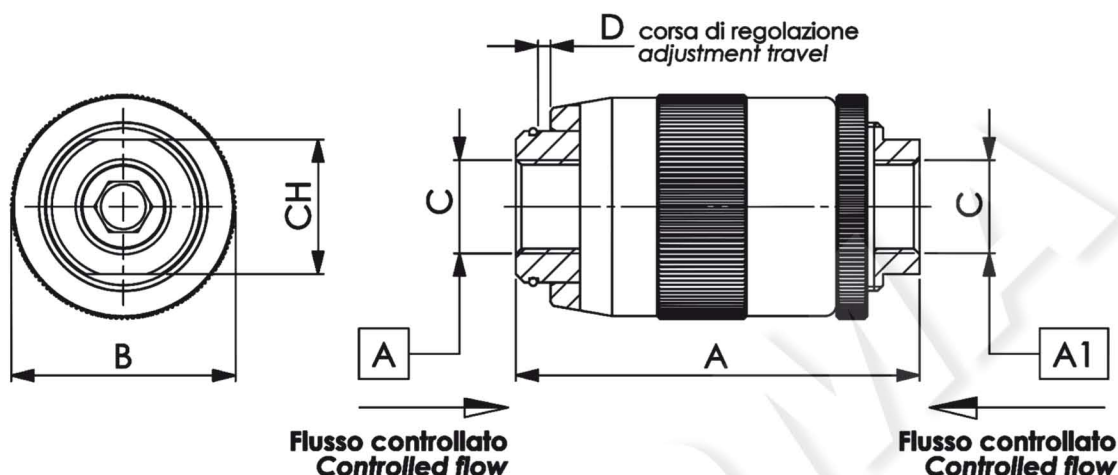

TIPO TYPE	PORTATA MAX. MAX FLOW	PRESSIONE MAX. MAX PRESSURE	A	B	C	D	CH	PESO WEIGHT
	L/MIN	BAR	mm	mm	BSPP	mm	mm	Kg
FPMB 1/4	12	350	62	34	1/4"	4.5	19	0.275
FPMB 3/8	30	350	72	40	3/8"	5.5	24	0.430
FPMB 1/2	45	310	80	46	1/2"	7	30	0.630
FPMB 3/4	85	280	100	54	3/4"	10	36	1.050
FPMB 1	150	250	125	65	1"	12	41	1.960

ESEMPIO DI ORDINAZIONE - ORDERING CODE EXAMPLE

FPMB 1 / 2 *

1/4 - 1/4" BSPP
 3/8 - 3/8" BSPP
 * 1/2 - 1/2" BSPP
 3/4 - 3/4" BSPP
 Connessioni - Port sizes

Guarnizioni - Seals:
 V=Viton *
 Omettere se BUNA-N - Omit if BUNA-N