

Part number:

HYDROMA
HYDRAULICKÉ SYSTÉMY**HIDROMA**
SYSTEMS
UKŁADY HYDRAULICZNE**HYDROMA**
ГИДРАВЛИЧЕСКИЕ СИСТЕМЫ

TECHNICAL SPECIFICATIONS

Pump Model		TPV 20	TPV 30
Max. displacement	cm ³ /n	20	30
Flow rating ⁽¹⁾	lt/min.	72	108
Power rating ⁽¹⁾	kW	25,2	37,8
Boost pump displacement (single pump)	cm ³ /n		6,4
Boost pump displacement (tandem pump)	cm ³ /n		9,5
Rated pressure	bar		210
Max. pressure	bar		350
Boost pressure ⁽²⁾	bar		10 - 18
Absolute suction pressure	bar		>= 0.8
Cold start absolute suction pressure	bar		>= 0.5
Max. case pressure	bar		1.5
Minimum speed	n/min.		700
Rated speed	n/min.		3600
Max. speed	n/min.		3900
Max. fluid temperature	°C		80
Fluid viscosity	mm ² /s		15 - 35
Fluid contamination		18/15/12 according ISO 4406 (NAS 9)	
Dry weight (single pump)	kg		12,2
Dry weight (tandem pump)	kg		28,5

(1) 3600 n/min. 210 bar

(2) 1500 n/min.

PERFORMANCE (Indicative Data)

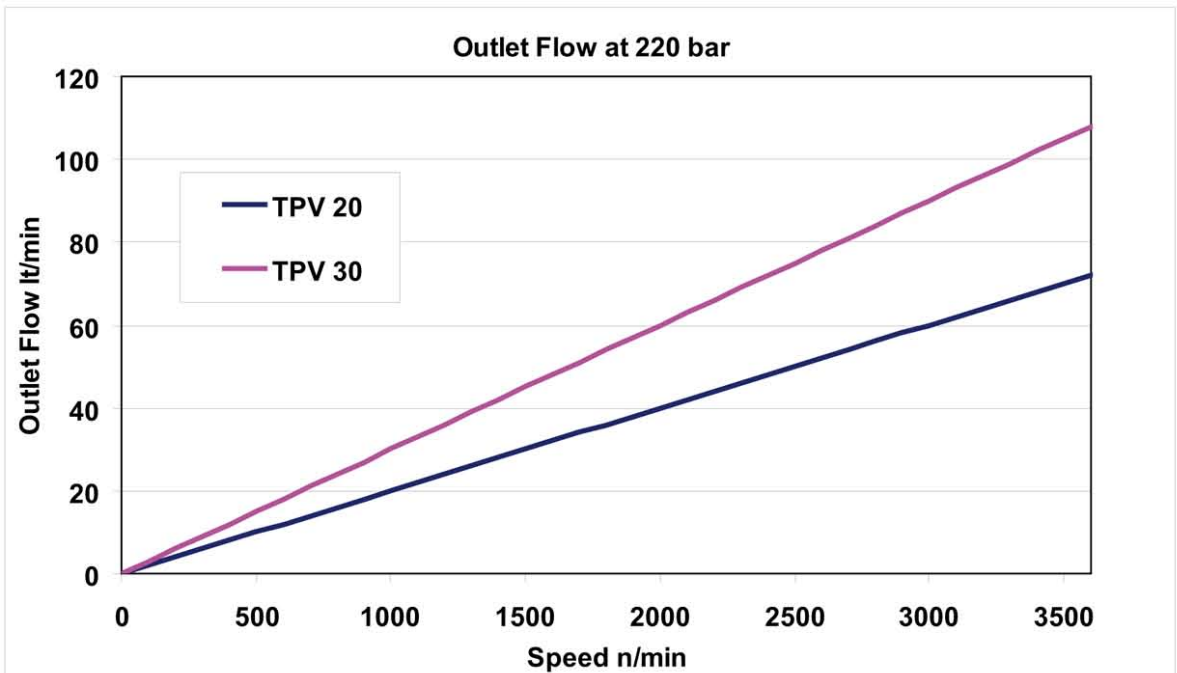
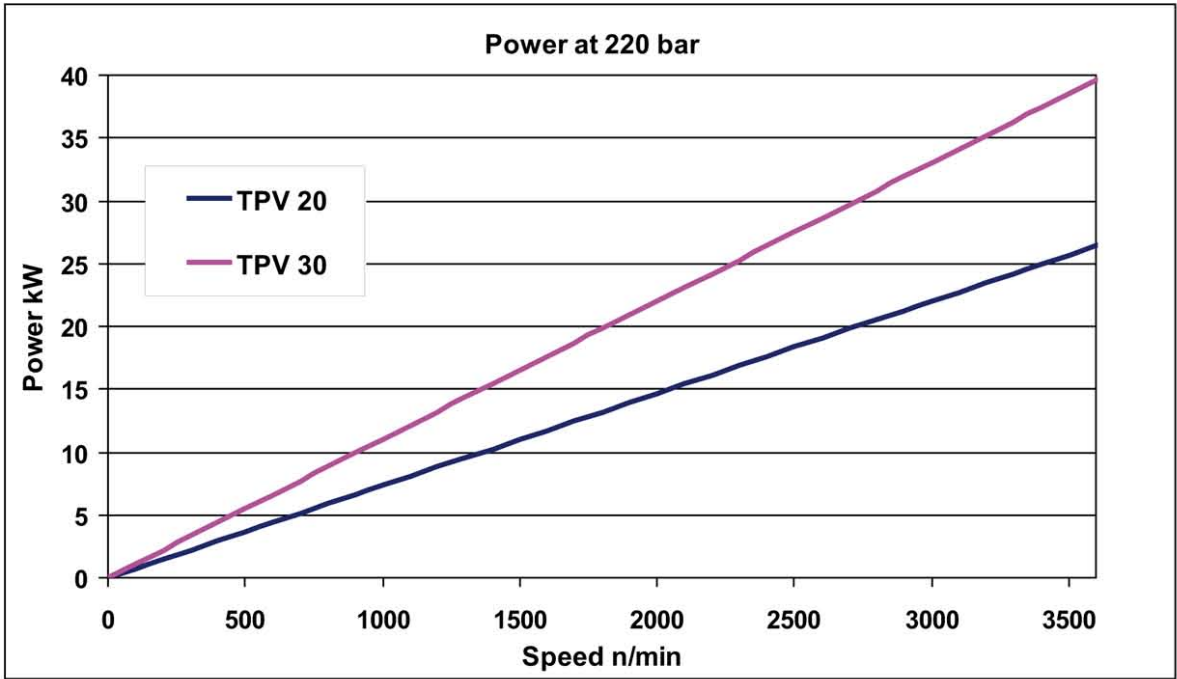

SINGLE PUMP - Direct Mechanical Control
INSTALLATION DRAWING

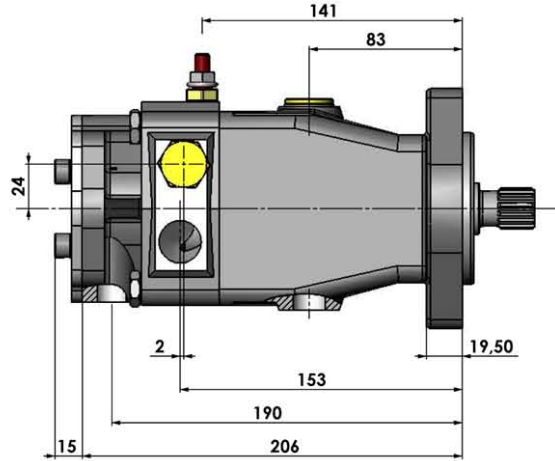
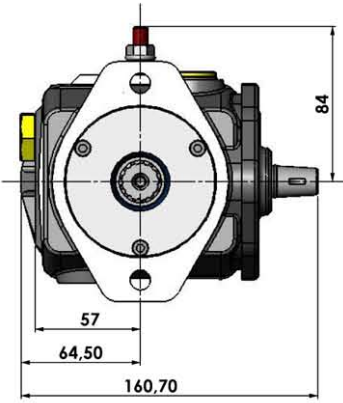

See shaft and flange details

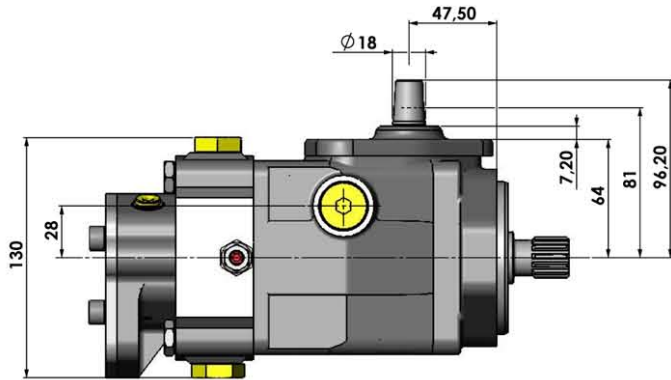
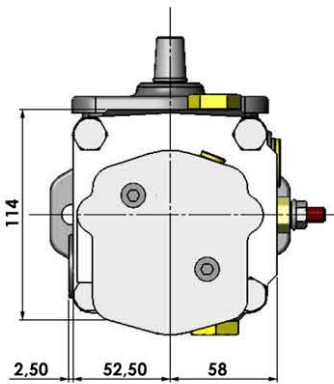

Hydraulic Diagram

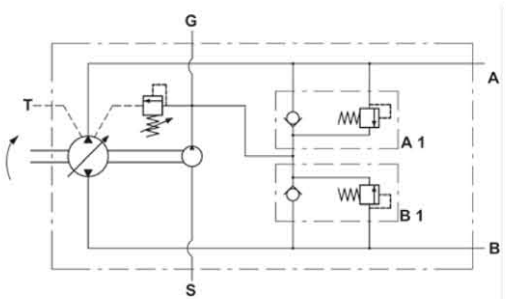

Pipe Connection		
A - B	Main Ports	3/4" BSP
D1 - D2	Drain	1/2" BSP
S	Suction	1/2" BSP
G	Charge System	1/2" BSP

TANDEM PUMP - Direct Mechanical Control

INSTALLATION DRAWING

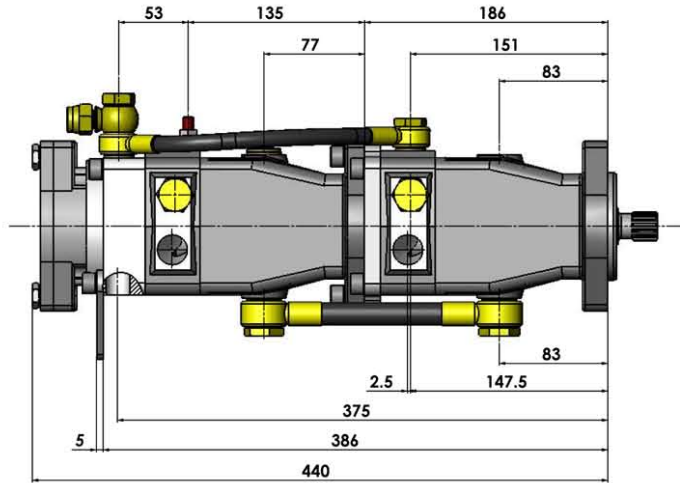
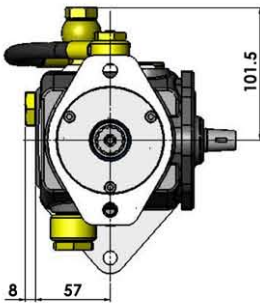

See shaft and flange details

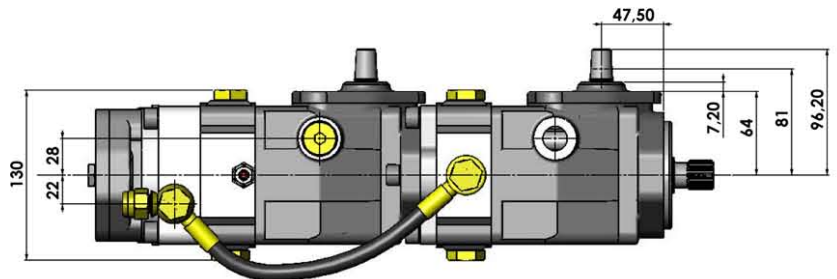
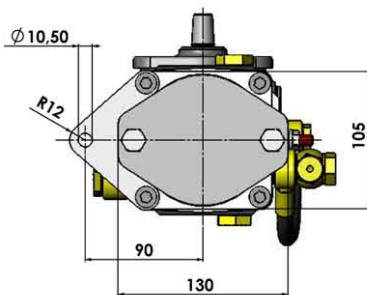

Pipe Connection		
A1 - B1	Main Ports Pump 1	3/4" BSP
A2 - B2	Main Ports Pump 2	1/2" BSP
D1 - D2	Drain	1/2" BSP
S	Suction	1/2" BSP
G	Charge System	1/2" BSP

Hydraulic Diagram

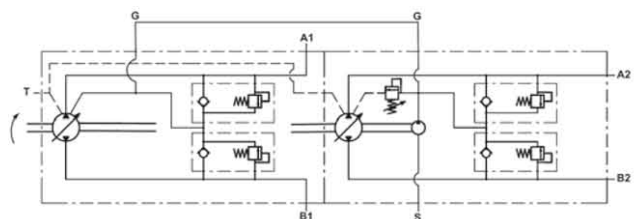

Mounting FLANGE

SAE A - 2 Holes Flange **F1**

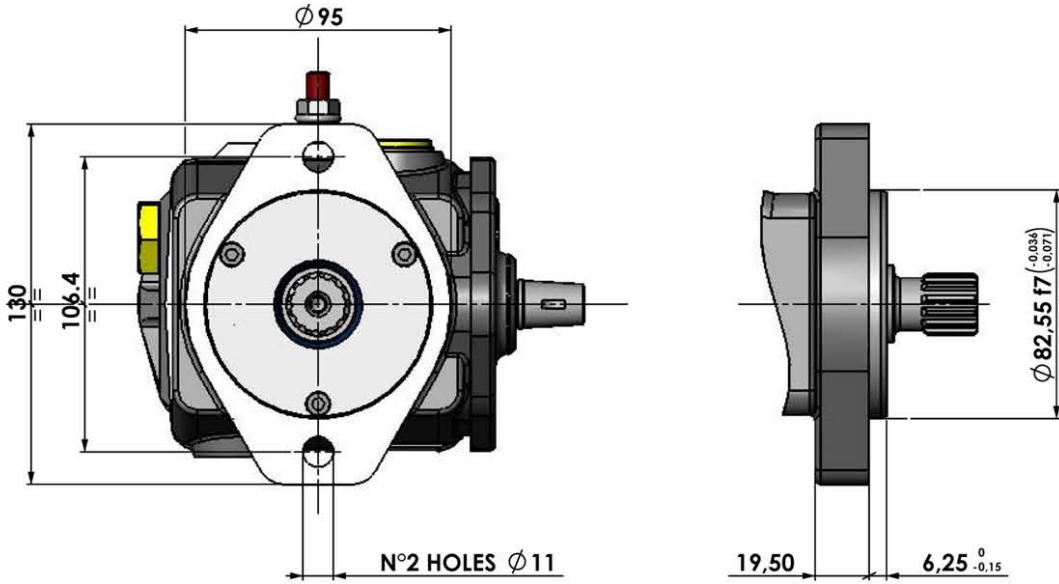

OPTIONAL

Adaptors Flange from SAE A to SAE B **FB**

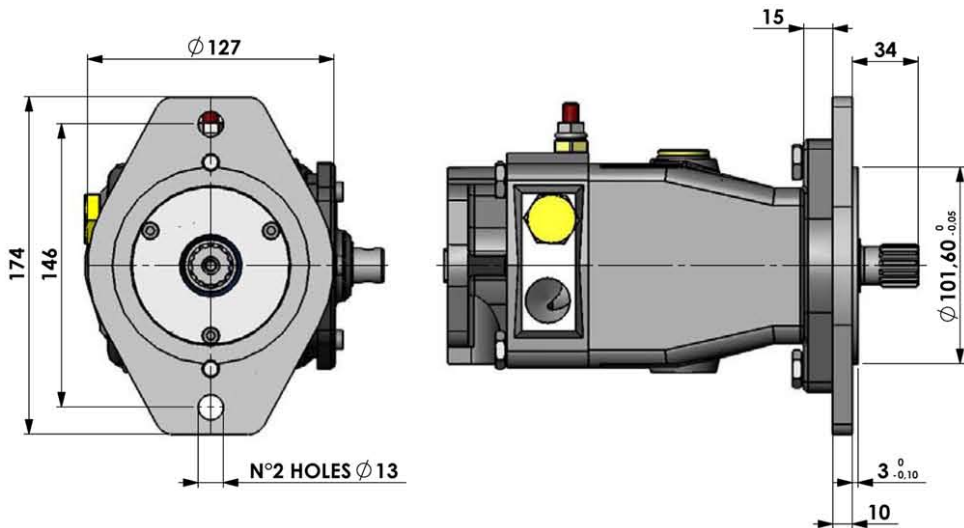

SHAFT

Parallel keyed shaft 22,22 mm. diam. **PS2**

Max. torque = 140 Nm

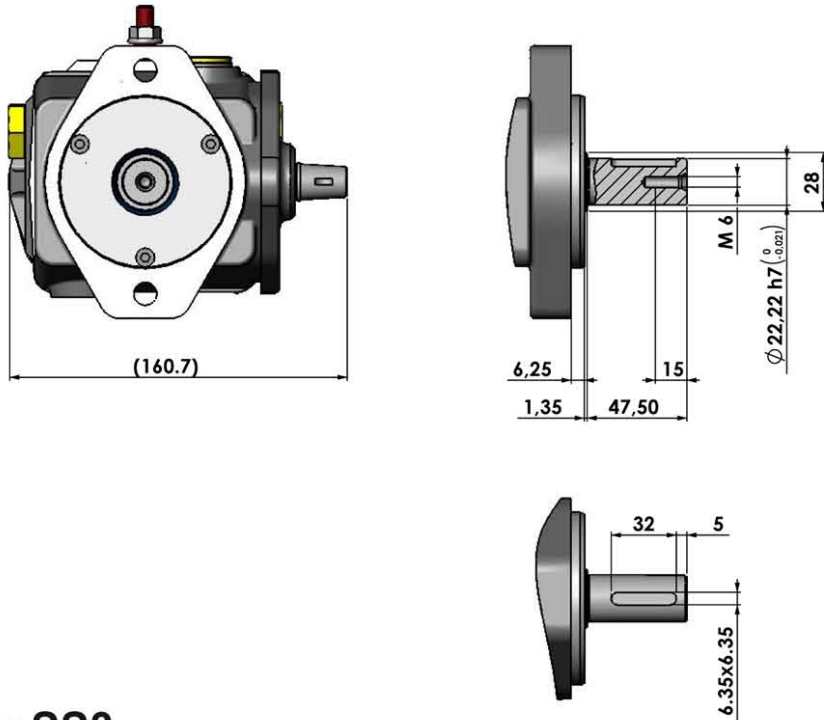

Splined shaft Z = 13 **SS3**

Max. torque = 320 Nm

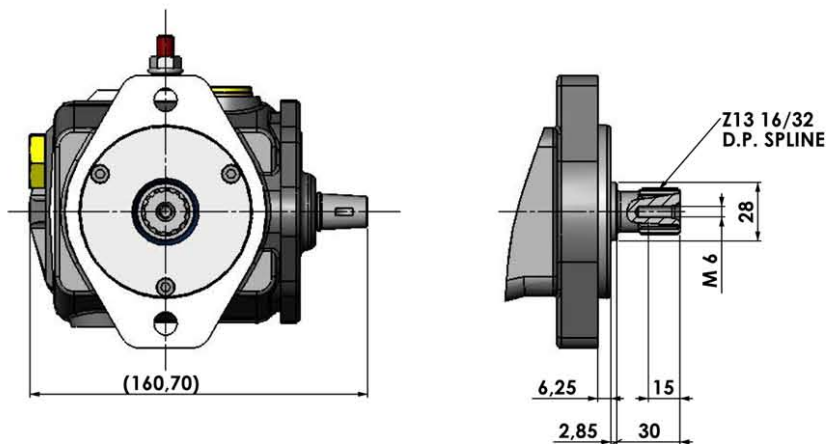

Attention: for the application of multiple pumps the total absorbed torque must not exceed the indicated value.

**Rear Pump Flange Connections
(Pump with Direct Mechanical Control)**

B1 - Gr 1 - German Standard

Max. torque = 48 Nm

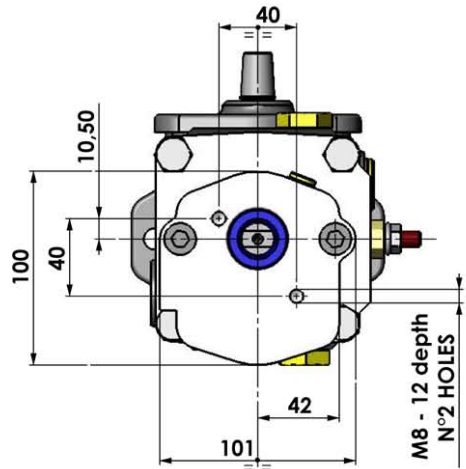
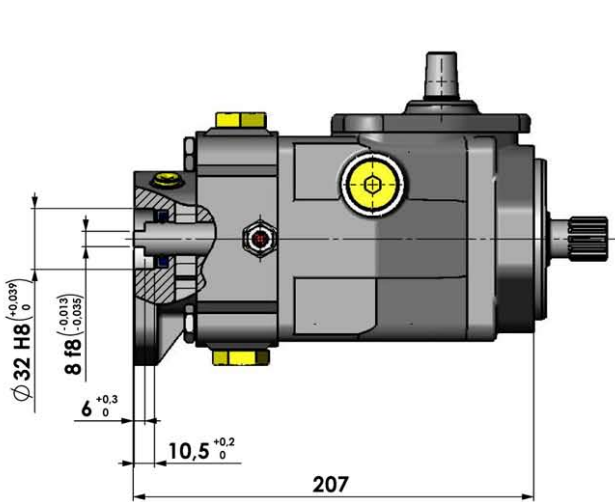

B2 - Gr 2 - German Standard

Max. torque = 52 Nm

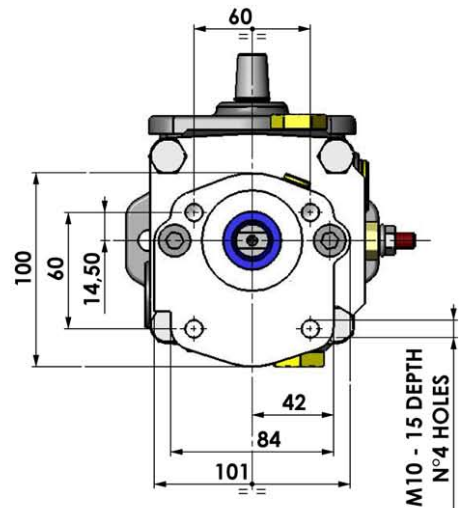
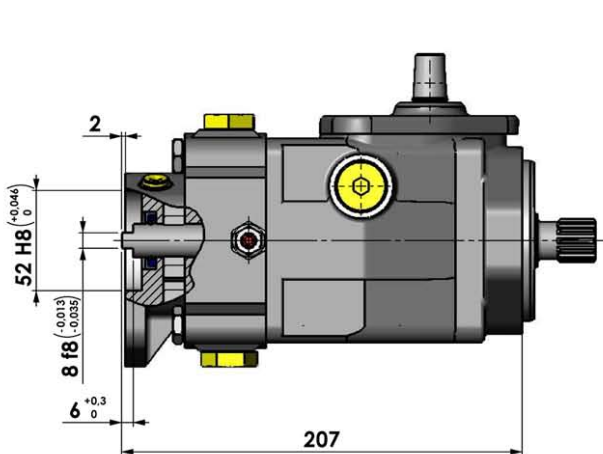

CONTROL DEVICES

Direct Mechanical Control Lever LC-TS

The pump displacement variation is obtained by rotate the control lever in a clockwise or counter-clockwise direction.
The control pin is linked to the pump swashplate with a 1:2 reduction ratio.

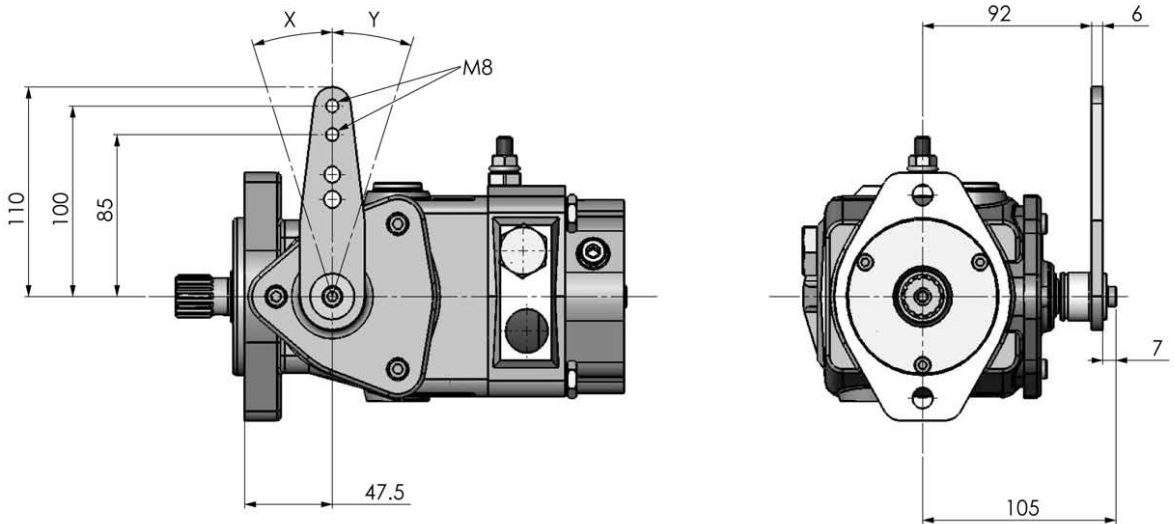

Flow Direction			
Pump Rotation	Lever Position	Flow Out	Flow In
Clockwise R	X	B	A
	Y	A	B

	X	Y
TPV 20	24°	24°
TPV 30	36°	36°

CONTROL DEVICE POSITION - Primary and Secondary Pump

OA



OB



LA



LB



RA



RB



ORDER CODE

2000	TPV	20	-	CR	SS3	F1	BC	OA	-	15	00	B1	000	00
0	1	2	3	4	5	6	7	8	9	10	11	12	13	14

Pag.

0 - Pump series

2000 = TPV pump 2000 (Ex 20-30)

1 - Pump model

TPV = Closed loop circuit single pump

TPV-T = Closed loop circuit tandem pump

TPVS* = Closed loop circuit special pump upon customer request

8

9

2 - Pump displacement (single or primary pump)

20 = 20 cm³/n

30 = 30 cm³/n

6

3 - Tandem pump displacement (secondary pump)

20 = 20 cm³/n

30 = 30 cm³/n

6

4 - Pump Rotation

CR = Clockwise Rotation (right)

5 - Shaft (mounting side)

SS3 = Splined shaft Z 13 - 16 / 32 D.P.

PS2 = Keyed Parallel shaft 22,22 diam. mm

11

6 - Mounting side flange

F1 = SAE A - 2 holes - pilot diam. 82,5 mm.

10

7 - Controls

DM-TS = Direct mechanical (tapered pin, without lever)

LC-TS = Standard control lever with tapered pin

DMS(40) = Integrated spring return control lever (spring diameter 4 mm)

BC = Tapered bush

16

14

15

16

8 - Control devices position (single or primary pump)

OA = Position A (without lever)

OB = Position B (without lever)

LA = Position A-left

RA = Position A-right

LB = Position B-left

RB = Position B-right

17

9 - Control devices position (secondary pump)

OA = Position A (without lever)

OB = Position B (without lever)

LA = Position A-left

RA = Position A-right

LB = Position B-left

RB = Position B-right

17

ORDER CODE (continued)

Pag.

10 - Relief valve pressure setting *

15	= 150 bar
18	= 180 bar
20	= 200 bar
25	= 250 bar
30	= 300 bar
35	= 350 bar

* **Attention:** the rated pressure value are changing with different speed.

11 - Charge pump

00	= Without charge pump
06	= Single boost pump 6,4 cm ³ /n - pressure 10 bar (1500 n/min)
09	= Tandem boost pump 9 cm ³ /n - pressure 10 bar (1500 n/min)

12 - Rear pump connection option

B1	= German standard group 1	12
B2	= German standard group 2	12
SA	= SAE A 2 holes mounting flange (female shaft)	13
C-B1	= Closed cover (with german standard group 1 pump's predisposition)	
C-B2	= Closed cover (with german standard group 2 pump's predisposition)	
C-SA	= Closed cover (with SAE A - 2 holes flange's predisposition)	

13 - Auxiliary gear pump displacement

000	= Without pump
-----	----------------

Group 1 German Standard (B1)

112 = 1,2 cm ³ /n	117 = 1,7 cm ³ /n	122 = 2,1 cm ³ /n	126 = 2,6 cm ³ /n
132 = 3,1 cm ³ /n	138 = 3,6 cm ³ /n	143 = 4,2 cm ³ /n	149 = 4,9 cm ³ /n
159 = 5,9 cm ³ /n	165 = 6,5 cm ³ /n	178 = 7,5 cm ³ /n	

Group 2 German Standard (B2)

204 = 4,2 cm ³ /n	206 = 6,0 cm ³ /n	209 = 8,4 cm ³ /n	211 = 10,8 cm ³ /n
214 = 14,4 cm ³ /n	217 = 16,8 cm ³ /n	219 = 19,2 cm ³ /n	222 = 22,8 cm ³ /n
226 = 26,2 cm ³ /n			

Group 2 SAE A

S 204 = 4,2 cm ³ /n	S 206 = 6,0 cm ³ /n	S 209 = 8,4 cm ³ /n	S 211 = 10,8 cm ³ /n
S 214 = 14,4 cm ³ /n	S 217 = 16,8 cm ³ /n	S 219 = 19,2 cm ³ /n	S 222 = 22,8 cm ³ /n
S 226 = 26,2 cm ³ /n	S 230 = 30,0 cm ³ /n		

14 - Optional

00	= Without optional
FB	= From SAE A to SAE B adaptor flange
SP	= Multiple pump support

10

ACCESSORIES

Hydraulic Gear Pump German Standard **B1**

Hydraulic Gear Pump German Standard **B2**

Hydraulic Gear Pump Gr 2 SAE A - 2 Holes **SA**



For more detailed information ask for catalogue HT 15 F.....

Flanges and Couplings for Gasoline and Diesel Engines

GASOLINE OR DIESEL ENGINES

FLANGES AND COUPLINGS

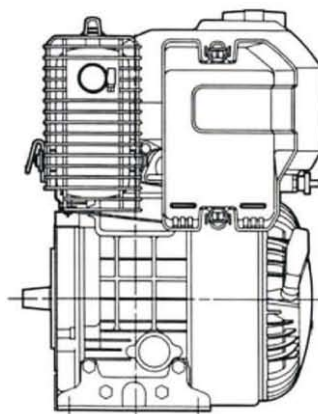
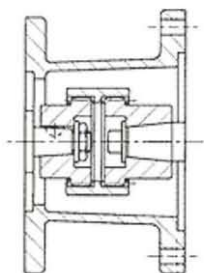

For more detailed information ask for specific catalogue