

Part number:

HYDROMA

HYDRAULICKÉ SYSTÉMY

**HIDROMA
SYSTEMS**

UKŁADY HYDRAULICZNE

HYDROMA

ГИДРАВЛИЧЕСКИЕ СИСТЕМЫ

RADIAL PISTON PUMP

RKP

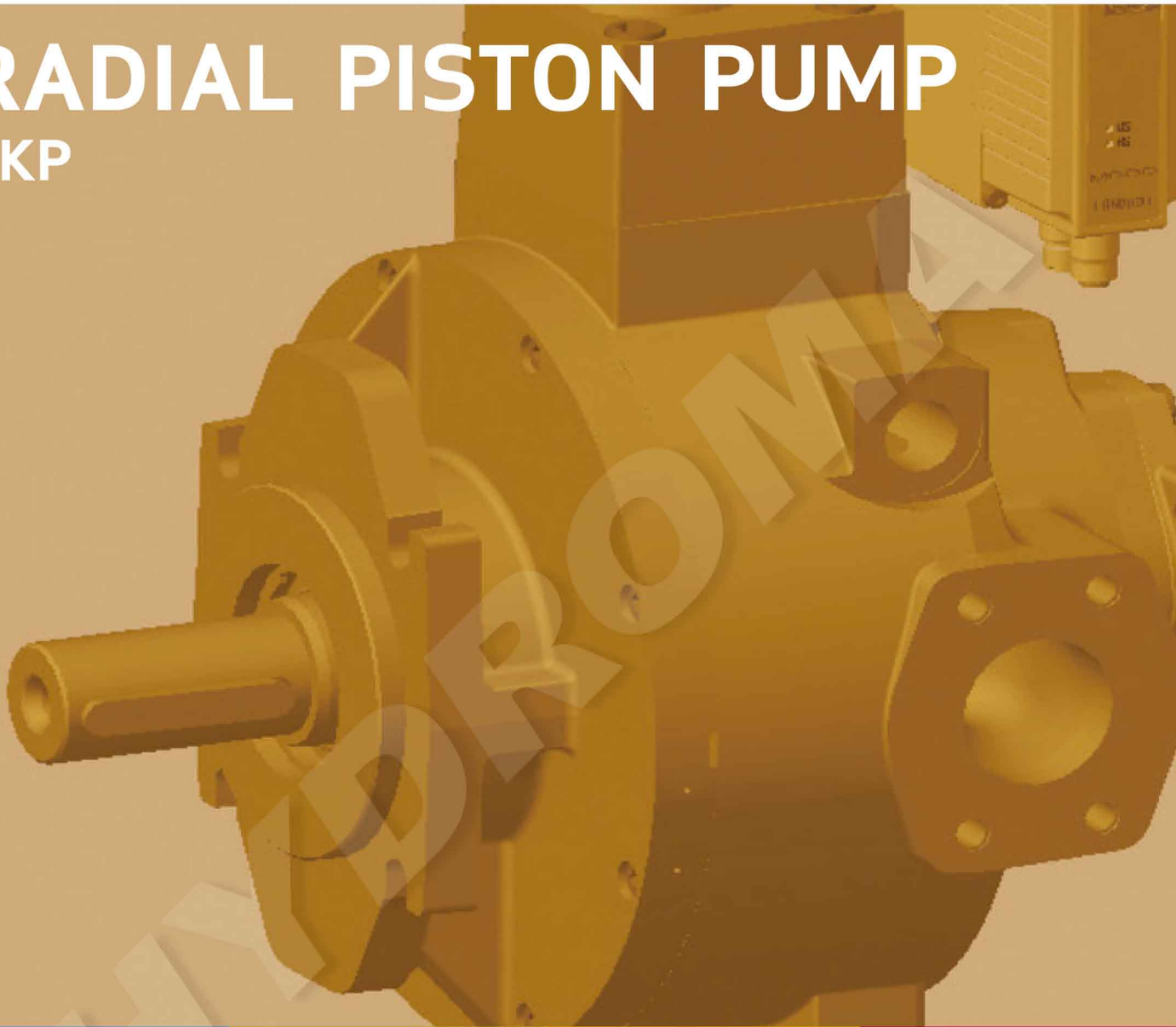

Rev. G, February 2015

MODULAR DESIGN FOR SUPERIOR PERFORMANCE
QUIET AND ROBUST

GENERAL INFORMATION

Outstanding Motion Control Solutions

For over 50 years, we have been a leader in motion control technology, specialising in the manufacture and application of high performance products. Today, we incorporate the latest motion control technology into our products and offer innovative ideas that can help our customers achieve new levels of machine performance.

Proven Pump Technology

The Radial Piston Pump product line (also known as RKP), is a range of high performance variable displacement pumps intended for use in industrial applications. Based on a proven concept, the RKP's robust and contamination resistant design results in long life and a high degree of reliability.

Its rapid response time and high volumetric efficiency have led to it being the first choice for many machines with demanding flow and pressure control needs.

We produce a wide range of radial piston pumps of different sizes, single and multiple arrangements, with various forms of control (mechanical, hydro-mechanical, electro-hydraulic, digital and analog) in order to provide maximum flexibility to machine builders.

Applications

Thanks to the flexible, high performance design, the RKP is the ideal solution for all types of industrial applications. The RKP is already used in machines for injection molding, die casting, forming equipment such as presses and rolls, as well as in general hydraulic applications. In the field of plastic and metal processing, the RKP is used on equipment to produce plastic and metal parts, for the packaging and automotive industries. The RKP is also used in test equipment, construction, rubber processing, and the mining industry.

The RKP is particularly well suited to applications where power, low noise and robust design, in combination with precision and speed are needed.

Low-Noise and Rugged Design

With a number of innovative design features we have been able to reduce both the primary and the secondary noise level from the RKP. For sizes 63 and 80 cm³/rev, the number of pistons have been increased from 7 to 9, reducing the working piston diameter leading to lower dynamic transverse forces acting on the housing.

As a result the flow and pressure pulsations on the high pressure side have been reduced, enabling the RKP to help machine manufacturers comply with EU directive "2003/10/EC" on noise emissions.

The design minimizes wear on the internal pump components, even under the most demanding operating conditions, thereby extending the service life of the machine.

RKP-II and RKP

During the introduction of the new pump design we have used the term "RKP-II" for clarity. By now only a very small portion of the deliveries remain on the old design, used mainly for replacements in existing equipment. The actual configuration is unequivocal in the model number. Therefore we have discontinued the use of the term "RKP-II" in our publications. In this catalog we use only the term "RKP" when we refer to the radial piston pump.

Digital or Analog Control

The control technology of the RKP pump has been significantly improved with a new integral closed-loop proportional valve, with digital on-board electronics for flow and pressure regulation, tuning, and diagnostics.

The RKP can be digitally controlled via a CANopen or EtherCAT interface or controlled by analog command signals.

Details of the significant benefits available from running the RKP in either fieldbus or analog modes are outlined in a separate catalog for the RKP-D pump.

PRODUCT DESCRIPTION

Quiet and Robust

Design

The RKP pumps benefit from low noise levels. Sizes 32 to 250 are fitted with a sliding stroke ring. The big suction port supports the use of wide suction lines. The control port of the compensators is built in G 1/4".

RKP stands for reliability, low noise, and durability and this is underlined by its extended warranty. Under the conditions described on page 5, warranty for mineral oil is covered for 10,000 operating hours or 24 months.

Further Advantages of the Moog Radial Piston Pump RKP are:

- Fast response
- Compact modular design enabling the pump selection to match the application
- Good suction characteristics
- Low pressure ripple

The following RKP features are available:

- Medium pressure series (280 bar (4,000 psi)) and high pressure series (350 bar (5,000 psi)) for mineral oil
- Large selection of compensators including mechanical, hydraulic and electro-hydraulic (analog or digital with CANopen or EtherCAT)
- Mechanical flow limitation
- Multiple pumps by tandem mounting
- Various drive flanges
- Suitable for most hydraulic oils such as mineral oil, transmission oil, biodegradable oil and synthetic esters (HFD)
- Suitable pump versions are also available for special fluids such as oil in water emulsions, (HFA and HFB), water-glycol (HFC), lubricating oils and cutting emulsions. See the catalog Radial Piston Pump RKP for Low-Flammability Fluids for details of these pumps.

Mode of Operation

The shaft (5) transfers the drive torque to the star-shaped cylinder block (3), free of any transverse forces via a crossdisc coupling (4). The cylinder block is supported on the control journal (1). The radial pistons (9) in the cylinder block run against the stroke ring (7) through hydrostatically balanced slipper pads (8). Piston and slipper pads are joined by ball and socket joints which is locked by a ring. The slipper pads are guided in the stroke ring by two retaining rings (2) and, when running, are held against the stroke ring by centrifugal force and oil pressure. As the cylinder block rotates, the pistons perform a reciprocating motion due to the eccentric positioning of the stroke ring, the piston stroke being twice the eccentricity. The eccentric position of the stroke ring is controlled by two diametrically opposed control pistons (6, 10) and the compensator (11). The oil flow to and from the pump passes through the pump ports and into and out of the pistons through the porting in the control journal. The rolling bearing, supporting the drive shaft, is only subjected to external forces. The compensator setting limits the system pressure and adjusts the pump flow between zero and full flow to maintain the set pressure. At the RKP-D the position of the stroke ring is detected by an LVDT (12) and high dynamically controlled by a servo pilot valve (13).

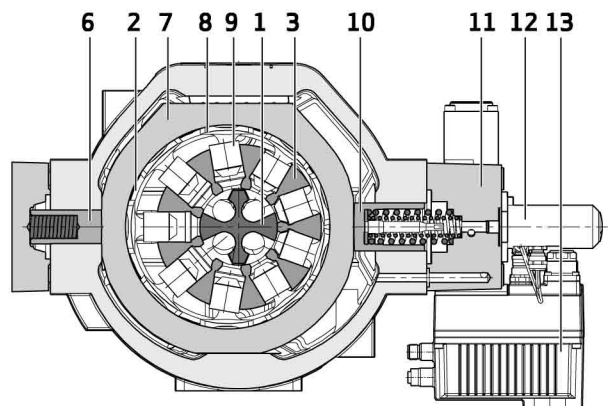
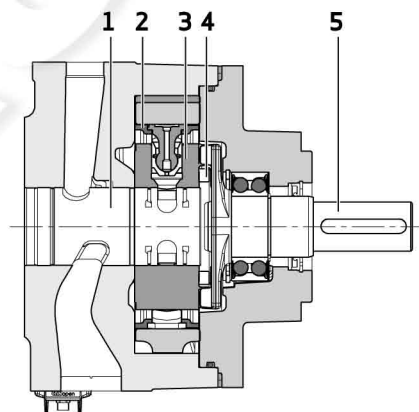

PRODUCT OVERVIEW

Displacement [cm ³ /rev]	19	32	45	63	80	100	140	250
Type of construction	Pump for open circuit with various control devices							
Type of mounting	End mounting, centering and hole-circle diameter to ISO 3019-2 (metric) Mounting flange to ISO 3019-1 (inch), Mounting flange to ISO 3019-2 (metric)							
Mounting position	Optional							
Weight [kg (lb)]	22 (49)	33 (73)	33 (73)	71 (157)	71 (157)	71 (157)	105 (232)	236 (521)
Mass moment of inertia [kg cm² (10⁻⁴ lbf in s²)]	17.7 (157)	61.0 (540)	61.0 (540)	186.3 (1,649)	186.3 (1,649)	186.3 (1,649)	380.0 (3,363)	1,555 (13,671)
Line connections according to ISO 6162:								
Medium pressure series 280 bar (4,000 psi)								
Pressure port	SAE 3/4"	SAE 1"	SAE 1"	SAE 1 1/4"	SAE 1 1/4"	SAE 1 1/4"	SAE 1 1/2"	
Suction port	3,000 psi SAE 3/4" 3,000 psi	3,000 psi SAE 1 1/2" 3,000 psi	3,000 psi SAE 1 1/2" 3,000 psi	3,000 psi SAE 2" 3,000 psi	3,000 psi SAE 2" 3,000 psi	6,000 psi SAE 2" 3,000 psi	6,000 psi SAE 2 1/2" 3,000 psi	
High pressure series 350 bar (5,000 psi)								
Pressure port	SAE 3/4"	SAE 1"		SAE 1 1/4"	SAE 1 1/4"			SAE 1 1/2"
Suction port	6,000 psi SAE 3/4" 6,000 psi	6,000 psi SAE 1 1/2" 3,000 psi		6,000 psi SAE 2" 3,000 psi	6,000 psi SAE 2" 3,000 psi			6,000 psi SAE 3" 3,000 psi
Recommended pipe OD for drain lines (lightweight version) [mm (in)]	15 (5/8")	18 (3/4")	18 (3/4")	22 (7/8")	22 (7/8")	22 (7/8")	22 (7/8")	35 (1 1/4")
Drain	The drain line is to be routed so that the pump housing is always full of the pumped fluid. The pressure at the drain port must not exceed 1 bar (15 psi) gauge pressure (2 bar (29 psi) absolute). The drain line to be piped directly to tank without filter, cooler, check valve etc. and must terminate below the minimum fluid level.							
Type of drive	Direct drive with coupling (please inquire from your Moog contact for other types)							
Ambient temperature range [°C (°F)]	-15 to +60 (+5 to +140)							
Maximum speed at inlet pressure 0.8 bar (12 psi) abs. [min⁻¹] 1 bar (15 psi) abs. [min⁻¹]	2,700 2,800	2,500 ¹⁾ 2,600 ¹⁾	2,000 ¹⁾ 2,100 ¹⁾	2,400 ¹⁾ 2,500 ¹⁾	2,000 ¹⁾ 2,050 ¹⁾	1,800 1,850	1,800 1,900	1,800 1,850
Maximum speed for quiet running [min⁻¹]	1,800	1,800	1,800	1,800	1,800	1,800	1,800	1,800
Minimum inlet pressure suction connection [bar (psi)]	0.8 (12) absolute							
Maximum housing pressure [bar (psi)]	2 (29) (1 (15) gauge pressure)							

For special fluids e.g., HFA, HFC and emulsions the above pressure, viscosity and filtration parameters may be changed. See the relevant special fluids catalog for details.

¹⁾ Maximum speed increase upon request

PRODUCT OVERVIEW

Displacement [cm ³ /rev]	19	32	45	63	80	100	140	250
Pressures [bar (psi)]								
Medium pressure series								
Continuous pressure	280 (4,000)	280 (4,000)	280 (4,000)	280 (4,000)	280 (4,000)	280 (4,000)	280 (4,000)	
Maximum pressure ²⁾	315 (4,500)	315 (4,500)	315 (4,500)	315 (4,500)	315 (4,500)	315 (4,500)	315 (4,500)	
Pressure peak	350 (5,000)	350 (5,000)	350 (5,000)	350 (5,000)	350 (5,000)	350 (5,000)	350 (5,000)	
High pressure series								
Continuous pressure	350 (5,000)	350 (5,000)		350 (5,000)	350 (5,000)			350 (5,000)
Maximum pressure ²⁾	385 (5,500)	385 (5,500)		385 (5,500)	385 (5,500)			385 (5,500)
Pressure peak	420 (6,000)	420 (6,000)		420 (6,000)	420 (6,000)			420 (6,000)
Hydraulic fluid	Mineral oil according to DIN 51524							
Hydraulic fluid temperature range [°C (°F)]	-15 to +80 (+5 to +176)							
Viscosity mm²/s (cSt)	Allowable viscosity operational range 12 to 100 Recommended viscosity 16 to 46; hydraulic fluid viscosity class VG 46 or VG 32 according to ISO 3448 Maximum viscosity 500 during start-up with electric motor at 1,800 min ⁻¹							
Filtering	NAS 1638, class 9; ISO 4406, class 20/18/15; obtained with filter fineness of $\beta_{20} = 75$ ³⁾ NAS 1638, class 7; ISO 4406, class 18/16/13; with electro-hydraulic control (RKP-D)							

For special fluids e.g., HFA, HFC and emulsions the above pressure, viscosity and filtration parameters may be changed. See the relevant special fluids catalog for details.

²⁾ Maximum pressure to ISO 5598

³⁾ Dirt particles retention rate > 20 μm is 1: 75, i.e. 98.67%

PERFORMANCE CURVES

Adjustment range

Caution: The rotation of the pump cannot be changed

Clockwise Rotation

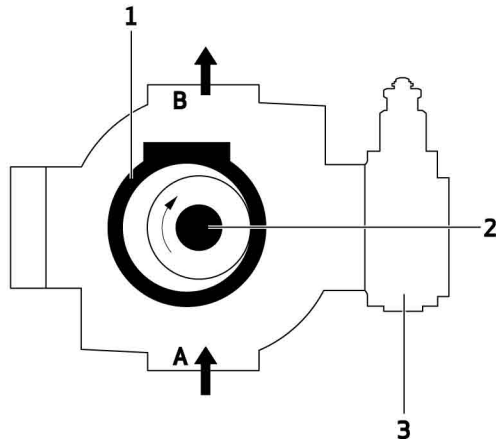

- 1 Stroke ring
- 2 Control journal
- 3 Compensator

Counterclockwise Rotation

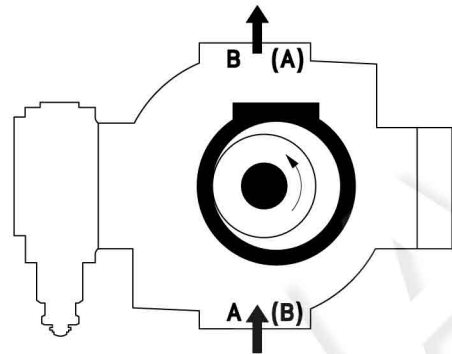

Suction port A
Suction port B

Power Consumption P

At maximum flow
Hydraulic fluid: Mineral oil
Viscosity $\nu = 35 \text{ mm}^2/\text{s}$ (cSt)
Temperature $T = +50 \text{ }^\circ\text{C}$ (+122 $^\circ\text{F}$)

Note: For RKP 19

Suction port (B)
Pressure port (A)

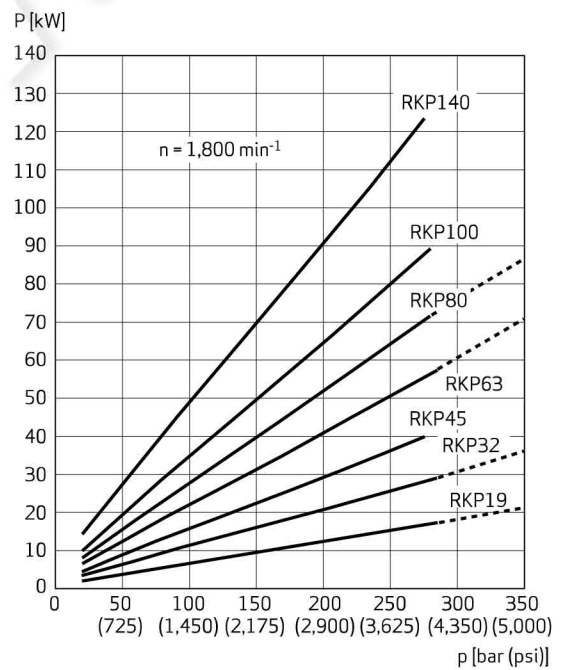
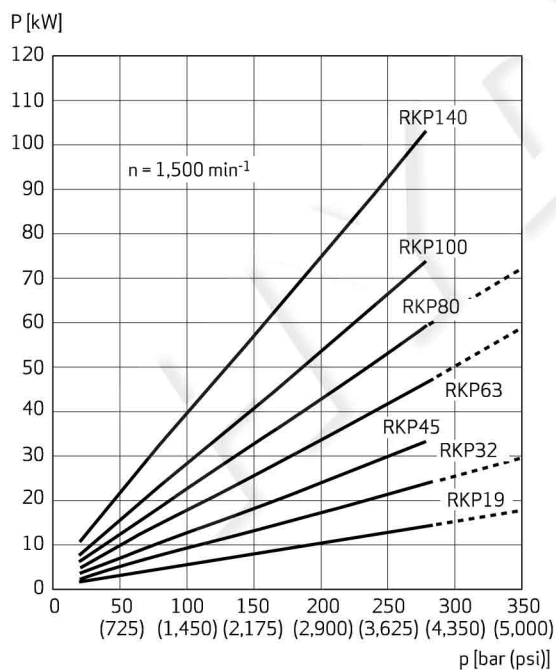

———— Standard version
 High-pressure version

PERFORMANCE CURVES

Noise Diagram

$n = 1,500 \text{ min}^{-1}$ at Q_{maximum}

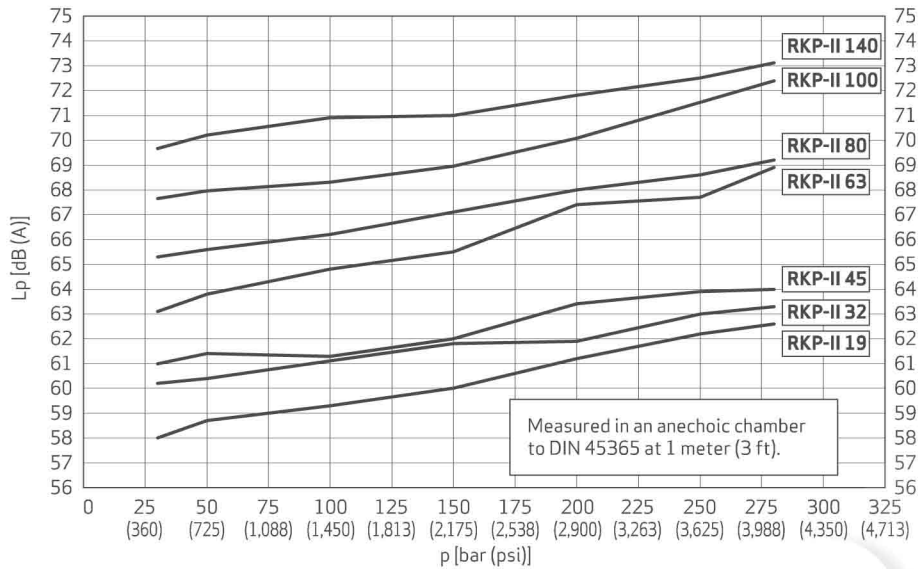

Noise emission values with combined pressure/flow compensator. These are average values over the operating range.

Performance Curves of Drive Power and Displacement

Response time $V_{\text{maximum}} \rightarrow V_{\text{minimum}}$: 20 to 50 ms (approx. value)

Response time $V_{\text{minimum}} \rightarrow V_{\text{maximum}}$: 50 to 100 ms

from 70 bar (1,015 psi) pressure setting (approx. value)

$n = 1,500 \text{ min}^{-1}$; $v = 35 \text{ mm}^2/\text{s}$ (cSt); $T = +50 \text{ }^\circ\text{C}$ (+122 $^\circ\text{F}$)

V = 19 cm³/rev

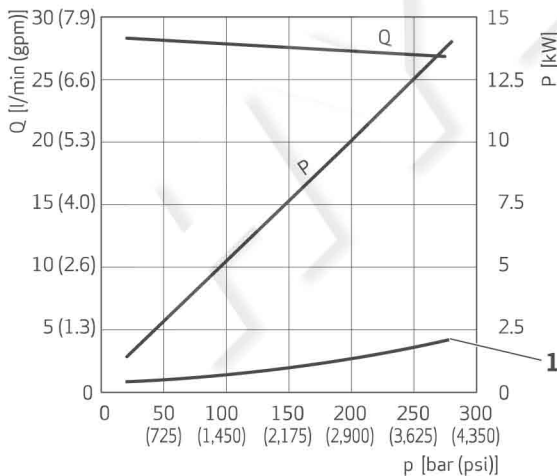

V = 32 cm³/rev

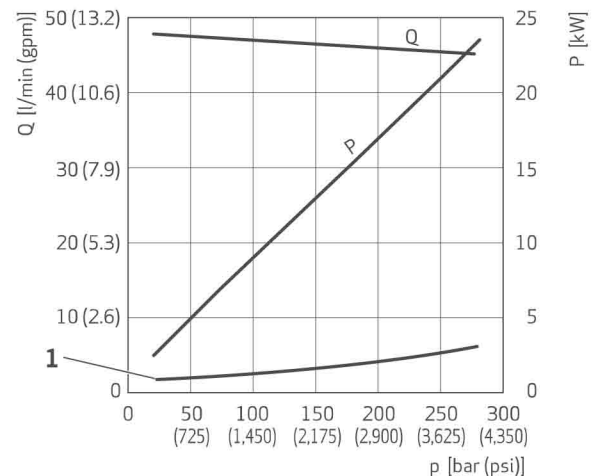

1 P at zero stroke

PERFORMANCE CURVES

V = 45 cm³/rev

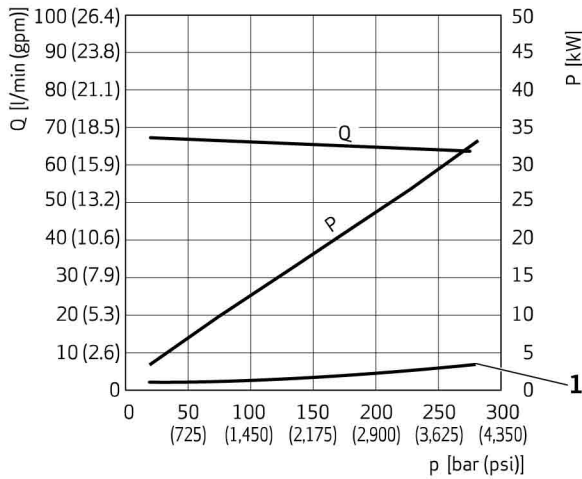

V = 63 cm³/rev

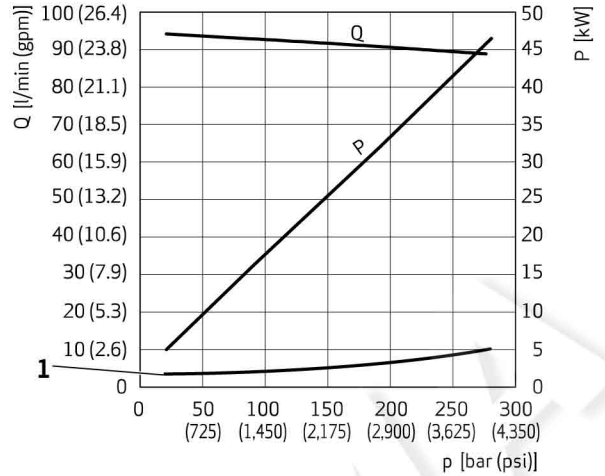

V = 80 cm³/rev

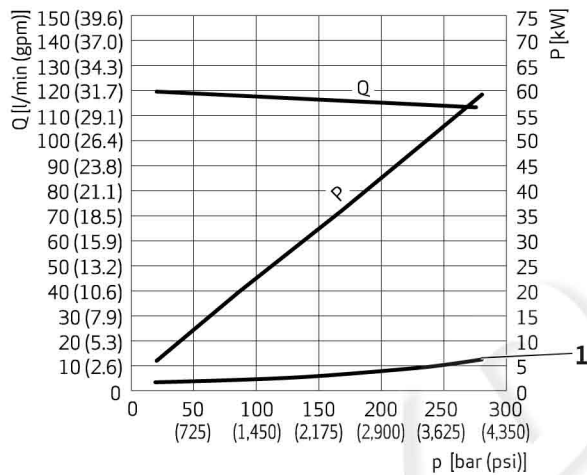

V = 100 cm³/rev

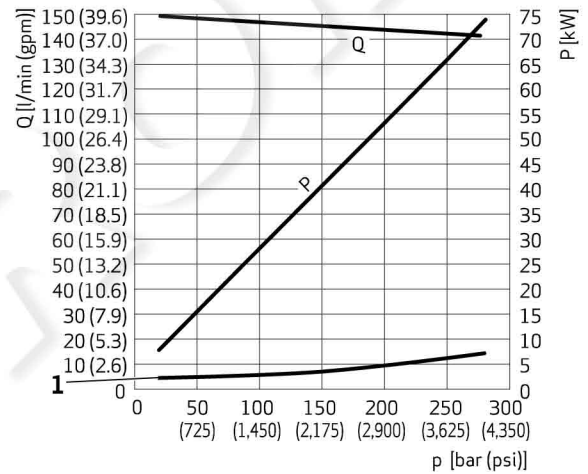

1 P at zero stroke

V = 140 cm³/rev

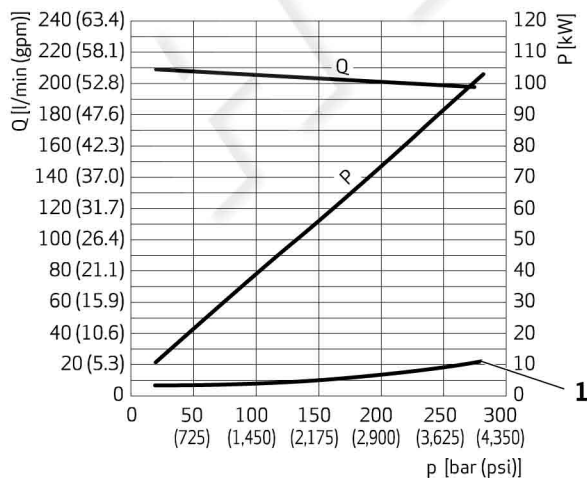

COMPENSATOR OPTIONS

RKP enables a variety of compensator options to be used thereby ensuring maximum flexibility.

The following options are described in more detail in appendix A.

Compensator option, Model code	Description/characteristics/application
1. Adjustable pressure compensator, Type F	For constant pressure systems with a fixed pressure setting
2. Remote pressure compensator, Type H1	For constant or variable pressure systems with remote pressure
3. Pressure compensator with Mooring control, Type H2	For constant pressure systems with a variable pressure setting for mooring control
4. Combined pressure and flow compensator, Type J	For displacement systems with a variable flow and load sensing pressure control
5. Combined pressure and flow compensator with P-T control notch, Type R	As 4. with additional active reduction of pressure peaks in the event of dynamic control process
6. Mechanical stroke adjustment, Type B	For displacement systems with a fixed displacement that may be manually adjusted as needed
7. Servo control, Type C1	Adjustment of displacement using a hand lever or an actuator
8. Constant horse-power control (force comparison system), Typ S1	Automatic reduction of displacement in the event of an increasing load so that the capacity of the drive motor is not exceeded
9. Constant horsepower control with remote pressure and flow control, Type S2	As 8. but with additional adjustable maximum limit for pressure and flow
10. Electro-hydraulically adjustable compensator with digital on-board electronics, Type D	For displacement systems with variable flow and/or pressure limitation
11. Dual-displacement, Type N1	For use in both speed variable operation and displacement controlled systems with two displacements at constant speed

MULTIPLE ARRANGEMENTS

Additional pumps can be tandem mounted on the radial piston pump, so that all pump stages can be driven by the same shaft. Radial piston pumps (the same size or smaller than the first pump stage) can be mounted directly.

Other pumps may be added on using adapter flanges for SAE-A, SAE-B or SAE-C respectively. For the maximum permitted through-drive torque for driving add-on pumps, please refer to the table below.

Adding on RKP, SAE-A, SAE-B or SAE-C Adapters Permissible Through-Drive Torques

Pump stage 1	Pump stage 2								
RKP	RKP					SAE-A	SAE-B	SAE-C	
Size (cm³/rev)	19	32 45	63 80 100	140	250				
19	90 Nm (797 lbf in)	–	–	–	–	90 Nm (797 lbf in)	–	–	–
32/45	185 Nm (1,637 lbf in)	185 Nm (1,637 lbf in)	–	–	–	110 Nm (974 lbf in)	185 Nm (1,637 lbf in)	–	–
63/80/100	400 Nm (3,540 lbf in)	400 Nm (3,540 lbf in)	400 Nm (3,540 lbf in)	–	–	110 Nm (974 lbf in)	280 Nm (2,478 lbf in)	400 Nm (3,540 lbf in)	–
140	400 Nm (3,540 lbf in)	400 Nm (3,540 lbf in)	400 Nm (3,540 lbf in) ¹⁾	620 Nm (5,487 lbf in)	–	110 Nm (974 lbf in)	280 Nm (2,478 lbf in)	620 Nm (5,487 lbf in)	–
250	400 Nm (3,540 lbf in)	400 Nm (3,540 lbf in)	400 Nm (3,540 lbf in)	620 Nm (5,487 lbf in)	1,470 Nm (13,009 lbf in)	110 Nm (974 lbf in)	280 Nm (2,478 lbf in)	1,300 Nm (11,505 lbf in)	–

¹⁾ Special flange for 620 Nm (5,487 lbf in) upon request

The through-drive torque required to drive add-on pumps is determined by reference to the following variables:

V [cm³/rev] Displacement
 p [bar] Pressure
 η_{hm} [%] Hydro-mechanical efficiency
 M [Nm] Through-drive torque

Through-drive torque from pump stage 1 to 2:

$$M_1 = 1.59 \cdot \sum_{i=2}^n \frac{V_i \cdot p_i}{\eta_{hmi}}$$

Example

If we take the following pump combination RKP 63 + RKP 63 + RKP 32 + AZP 16 280 bar (4,000 psi), 210 bar (3,000 psi), 150 bar (2,176 psi), 50 bar (725 psi), the following considerations apply:

Design of 1st Through-Drive

The pressure and flow of the 1st pump stage are irrelevant to the torque transferred by the through-drive. This torque can be calculated using the above formula.

$$M_1 = 1.59 \cdot \left(\frac{V_2 \cdot p_2}{\eta_{hm2}} + \frac{V_3 \cdot p_3}{\eta_{hm3}} + \frac{V_4 \cdot p_4}{\eta_{hm4}} \right)$$

$$M_1 = 1.59 \cdot (63 \cdot 210/95 + 32 \cdot 150/93 + 16 \cdot 50/90) \text{ Nm}$$

$$M_1 = 318 \text{ Nm}$$

The value 318 Nm (2,814 lbf in) is below the threshold value of 400 Nm (3,540 lbf in) specified in the above table for mounting an RKP 63 on another RKP 63.

Design of 2nd Through-Drive Torque

$$M_2 = 1.59 \cdot \left(\frac{V_3 \cdot p_3}{\eta_{hm3}} + \frac{V_4 \cdot p_4}{\eta_{hm4}} \right)$$

$$M_2 = 1.59 \cdot (32 \cdot 150/93 + 16 \cdot 50/90) \text{ Nm}$$

$$M_2 = 96 \text{ Nm}$$

Likewise, the value 96 Nm (850 lbf in) lies below the relevant threshold value of 400 Nm (3,540 lbf in) for the through-drive from RKP 63 to an RKP 32.

Design of 3rd Through-Drive Torque

Similarly, a value of 14 Nm (124 lbf in) is obtained for the torque required to drive the add-on gear pump. Thus, the through-drives for this pump combination are permissible with the stated pressures.

TECHNICAL INFORMATION

Important

The pump must be put into service by a trained hydraulic systems engineer.

Installation

The radial piston pump can be mounted in any position. The drive shaft must not be subject to radial or axial loads and should therefore to be driven through a flexible coupling. The pump must be driven in the correct direction of rotation. All plugs on the pump should only be removed immediately before the pipes are connected and standard hydraulic cleanliness procedures to be used. The use of cold drawn seamless steel pipes in accordance with DIN 2391 is recommended.

Suction Line (A)

It is recommended that final piping connections to the pump are flexible hoses. The shortest possible suction line should be used with a diameter large enough to give a fluid velocity below 1.5 m/s (0.06 in/s). Sharp angles and screwed pipe joints should be avoided due to the danger of air ingress and excessive pressure drop therefore, pipe bends and/or hoses should be used. The minimum permissible inlet pressure must be maintained. If a suction filter (minimum 0.15 mm (0.01 in) mesh aperture) or an isolating valve is to be used, it must be installed below the fluid level.

Pressure Line (B)

Ensure the pressure pipework is securely clamped and the screws are correctly torque tightened.

Drain Line (L)

The upper drain port must be used for the drain line and the pipework is to be routed to ensure the housing is always full of fluid. The pipe should lead directly to the tank, separate from other return lines. For RKP250 port L1 must be used for drain line connection. The bearing cover of the pump must be assembled with port L1 in upper position. For description of port L2 see further information in chapter "Flushing the housing". It must terminate below the lowest fluid level and should be as far away from the suction take off as possible. Do not fit a filter, cooler or non-return valve in the drain line. The maximum recommended length for the drain line is 3 m (10 ft). The pressure at drain port is not to exceed 1 bar gauge (15 psi) (2 bars absolute (29 psi)). The recommended outside pipe diameters for drain lines (lightweight version) are:

RKP 19: 15 mm (5/8")

RKP 32 and 45: 18 mm (3/4")

RKP 63, 80, 100 and 140: 22 mm (7/8")

RKP 250: 35 mm (1 1/4")

Flushing the Housing

For heat dissipation it is necessary to flush the pump under the following conditions:

- Pump sizes 63 to 100 cm³/rev
If the pump is operated at low pressure without flow for long periods ($t > 15$ min, $p < 30$ bar (435 psi), $Q = 0$ l/min (0 gpm))
- Pump sizes 140 and 250 cm³/rev
Flushing the Housing is necessary in general at any time

The flushing line to the pump must be connected to the lower drain port. For RKP 250 the flushing line to the pump must be connected to port L2.

Flush volume

Displacement V [cm ³ /rev]	63, 80, 100	140	250
Flush volume [l/min (gpm)]	4 to 6 (1 to 1.5)	6 to 8 (1.5 to 2)	10 to 12 (2.5 to 3)

Noise Development

Radial piston pumps have a low primary noise level. However, the overall noise level hydraulic of the unit depends on the pump mounting and piping layout and the transmitted noise can be prevented by:

- Connecting the pump to the bellhousing using an anti-vibration flange.
- Use flexible hoses instead of solid pipes.
- Clamp the pipework with elastic insert clamps.

Connections

Suction line to port A and pressure line from port B. Except for RKP 19 counterclockwise: Suction port B, pressure port A.

Putting into Service

Do not start up the pump without hydraulic fluid. Before switching on, the pump housing must be filled with hydraulic fluid using the higher drain port.

Jog start the electric motor to check the correct direction of rotation. Run the pump at low pressure until the hydraulic system has been fully de-aerated. When putting pumps for HF fluids into operation, the system must be run at low pressure of between 30 to 50 bar (435 to 725 psi) for approximately 1 hour.

Important

The oil temperature in the tank must not exceed the temperature of the pump by more than +25 °C (+77 °F).

If this should occur, the pump must be jog started for intervals of approximately 1 to 2 seconds until pump casing has heated up. When changing a pump, clean the suction pipe, drain line and tank. Refill the tank with filtered oil.

APPENDIX A – COMPENSATOR OPTIONS

Remote Pressure Compensator H1

Pressure pilot valve:

Manual remote adjustable or proportional pressure valve.

$Q = 0.5$ to 1.5 l/min (0.1 to 0.4 gpm)

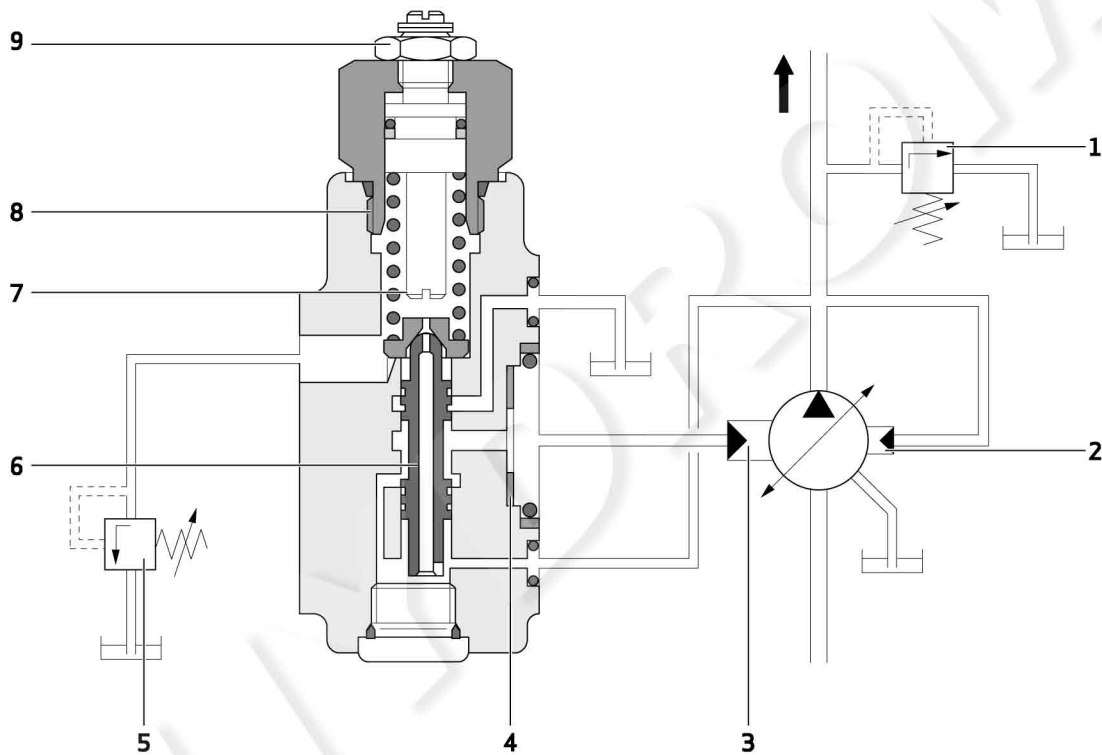
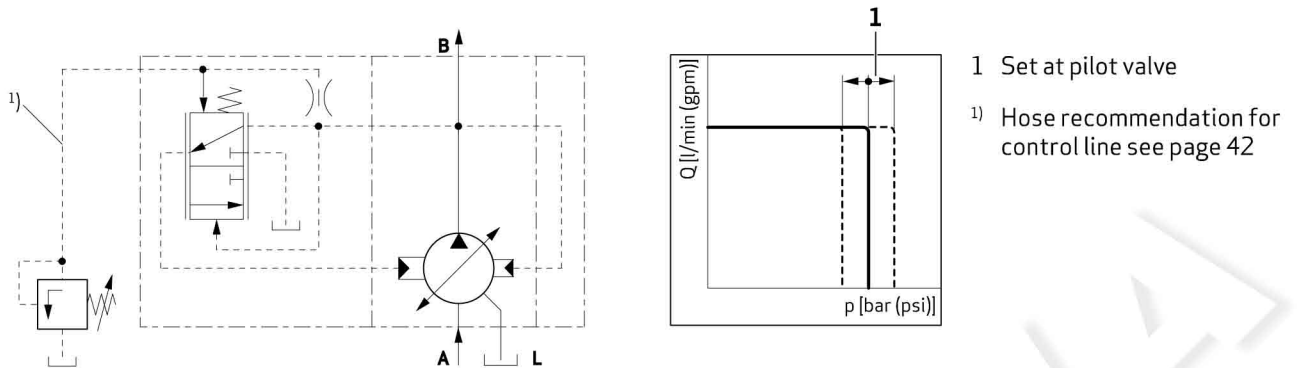

1 Safety valve $p = p_{\text{maximum}} + 30$ bar (435 psi)

2 Control piston 2

3 Control piston 1

4 Adjustment of zero stroke

5 Pressure pilot valve

6 Valve spool

7 Orifice

8 p_{minimum} -spring

9 Locked screw

APPENDIX B – TECHNICAL DRAWINGS RKP 19 TO 100

Housings

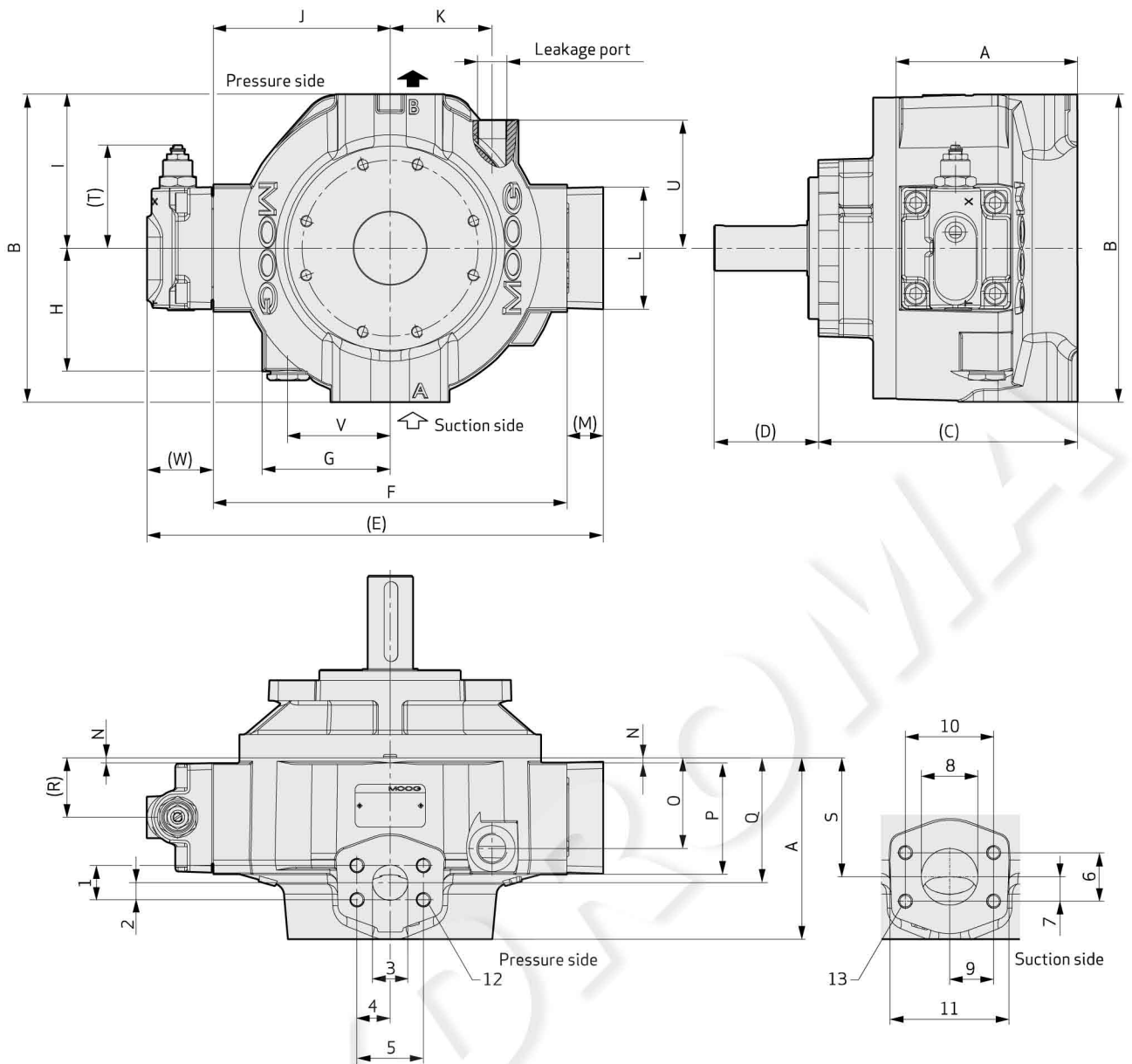

Caution! Figure presents clockwise direction.

For counterclockwise direction the compensator is build for the opposite side. Change of rotation is **not** possible.

Multiple arrangement: Example RKP 63 + RKP 32

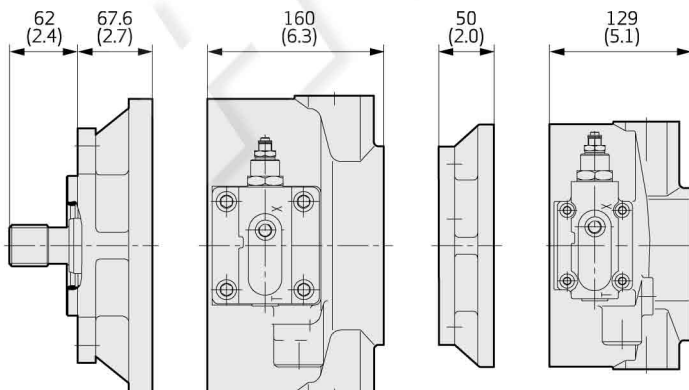

APPENDIX B – TECHNICAL DRAWINGS RKP 19 TO 100

Housings

[mm (in)]		RKP 19	RKP 32/45	RKP 63/80/100	
Length	A	104.00 (4.09)	129.00 (5.08)	160.00 (6.30)	
	B	181.00 (7.13)	225.00 (8.87)	272.00 (10.72)	
Height	(C)¹⁾	163.10 (6.43)	193.10 (7.60)	228.60 (9.00)	
	(D)¹⁾	46.10 (1.81)	78.00 (3.07)	92.00 (3.62)	
	(E)²⁾	290.50 (11.45)	319.30 (12.58)	402.50 (15.86)	
	F	212.00 (8.35)	241.00 (9.50)	312.10 (12.30)	
	G	78.00 (3.07)	97.00 (3.82)	113.00 (4.45)	
	H	83.00 (3.27)	87.00 (3.42)	108.00 (4.26)	
	I	90.50 (3.57)	112.50 (4.43)	136.00 (5.36)	
	J	106.00 (4.18)	120.50 (4.75)	156.00 (6.14)	
	K	56.00 (2.20)	84.00 (3.30)	90.00 (3.55)	
	Leakage port		M18 x 1.5 (0.06) – 13 (0.51) deep	M22 x 1.5 (0,06) – 14 (0.55) deep	M26 x 1.5 (0.06) – 16 (0.63) deep
		L	80.00 (3.15)	81.40 (3.20)	107.70 (4.24)
(M)²⁾		26.00 (1.02)	26.00 (1.02)	32.00 (1.26) (51.7 (2.04) at D2, D3, D6)	
N		1.00 (0.03)	7.50 (0.31)	4.30 (0.17)	
O		55.00 (2.17)	66.00 (2.60)	80.00 (3.15)	
P		70.00 (2.76)	75.50 (2.98)	98.50 (3.88)	
Q		67.00 (2.63)	88.00 (3.47)	110.00 (4.33)	
(R)²⁾		35.00 (1.38)	41.20 (1.62)	52.25 (2.06)	
S		67.00 (2.63)	85.00 (3.35)	105.00 (4.13)	
(T)²⁾		Maximum 103.00 (4.06)	Maximum 103.00 (4.06)	Maximum 98.00 (3.86)	
U		83.00 (3.27)	87.00 (3.42)	113.00 (4.45)	
V		56.00 (2.20)	78.00 (3.07)	90.00 (3.55)	
(W)²⁾		52.50 (2.07)	52.30 (2.06)	58.40 (2.30)	

¹⁾ Value for flange A7

²⁾ Value for compensators F, H, J, R without maximum flow limiter

APPENDIX B – TECHNICAL DRAWINGS RKP 19 TO 100

Housings

[mm (in)]	RKP 19		RKP 32/45		RKP 63/80/100	
Pressure port	SAE 3/4" 3,000 psi	SAE 3/4" 6,000 psi	SAE 1" 3,000 psi	SAE 1" 6,000 psi	SAE 1 1/4" 3,000 psi	SAE 1 1/4" 6,000 psi
1	22.20 (0.87)	23.90 (0.94)	26.20 (1.05)	27.80 (1.10)	30.16 (1.19)	31.70 (1.25)
2	11.10 (0.44)	11.95 (0.47)	13.10 (0.52)	13.90 (0.55)	15.08 (0.59)	15.85 (0.62)
3	19.00 (0.75)	19.00 (0.75)	25.00 (0.98)	25.00 (0.98)	26.00 (1.02)	31.00 (1.22)
4	23.81 (0.94)	25.40 (1.00)	26.20 (1.05)	28.60 (1.13)	29.37 (1.16)	33.34 (1.31)
5	47.60 (1.87)	50.80 (2.00)	52.40 (2.06)	57.20 (2.25)	58.74 (2.31)	66.68 (2.63)
12	M10 16 (0.63) deep	M10 16 (0.63) deep	M10 16 (0.63) deep	M12 21 (0.83) deep	M12 21 (0.83) deep	M14 24 (0.94) deep
Suction port	SAE 3/4" 3,000 psi	SAE 3/4" 6,000 psi	SAE 1 1/2" 3,000 psi		SAE 2" 3,000 psi	
6	22.20 (0.87)	23.90 (0.94)	35.70 (1.41)		42.80 (1.69)	
7	11.10 (0.44)	11.95 (0.47)	17.85 (0.70)		21.40 (0.84)	
8	19.00 (0.75)	19.00 (0.75)	38.00 (1.50)		50.00 (1.97)	
9	23.81 (0.94)	25.40 (1.00)	34.95 (1.38)		38.90 (1.53)	
10	47.60 (1.87)	50.80 (2.00)	69.90 (2.75)		77.80 (3.06)	
11	71.00 (2.80)	71.00 (2.80)	98.00 (3.86)		105.00 (4.13)	
13	M10 16 (0.63) deep	M10 16 (0.63) deep	M12 24 (0.94) deep		M12 22.5 (0.89) deep	

APPENDIX B – TECHNICAL DRAWINGS RKP 19 TO 100

Drive Flanges A1

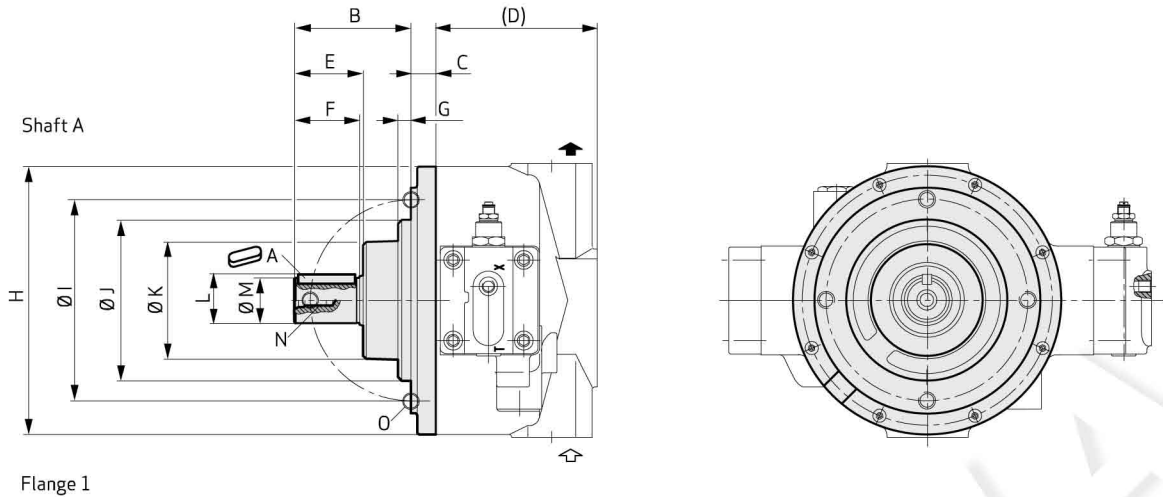

Key to DIN 6885
Metric round flange

[mm (in)]	RKP 19	RKP 32/45	RKP 63/80/100
A	A 8 x 7 x 32 DIN 6885	A 10 x 8 x 45 DIN 6885	A 14 x 9 x 56 DIN 6885
B	70.70 (2.78)	94.50 (3.72)	116.00 (4.57)
C	17.10 (0.67)	18.10 (0.71)	24.70 (0.97)
(D)	104.00 (4.09)	129.00 (5.08)	160.00 (6.30)
E	42.90 (1.69)	57.50 (2.27)	68.50 (2.70)
F	41.20 (1.62)	55.00 (2.17)	65.00 (2.56)
G	11.40 (0.45)	11.00 (0.43)	13.00 (0.51)
H	177.00 (6.97)	220.00 (8.66)	267.00 (10.51)
I	125.00 ±0.15 (4.92 ±0.0059)	160.00 ±0.15 (6.30 ±0.0059)	200.00 ±0.15 (7.87 ±0.0059)
J	100.00 -0.036/-0.09 (3.94 -0.0014/-0.0035)	125.00 -0.043/-0.106 (4.92 -0.0017/-0.0041)	160.00 -0.043/-0.106 (6.30 -0.0017/-0.0041)
K	79.00 (3.11)	101.00 (3.98)	116.00 (4.57)
L	30.75 (1.21)	37.85 (1.49)	48.40 (1.91)
M	28.00 -0.013 (1.10 -0.0005)	35.00 -0.016 (1.38 -0.0006)	45.00 -0.016 (1.77 -0.0006)
N	M10 22 (0.87) deep	M10 22 (0.87) deep	M10 32 (1.26) deep
O	M10 15 (0.59) deep	M12 16 (0.63) deep	M16 23 (0.91) deep

APPENDIX B – TECHNICAL DRAWINGS RKP 19 TO 100

Compensators

Adjustable Pressure Compensator F1, F2

Remote Pressure Compensator H1

Combined Pressure and Flow Compensator J1, J2

Combined Pressure and Flow Compensator with P-T Control Notch R1

RKP 19/32/45

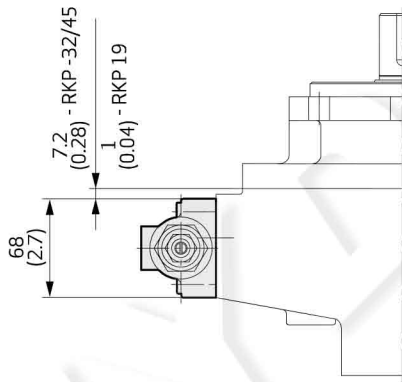
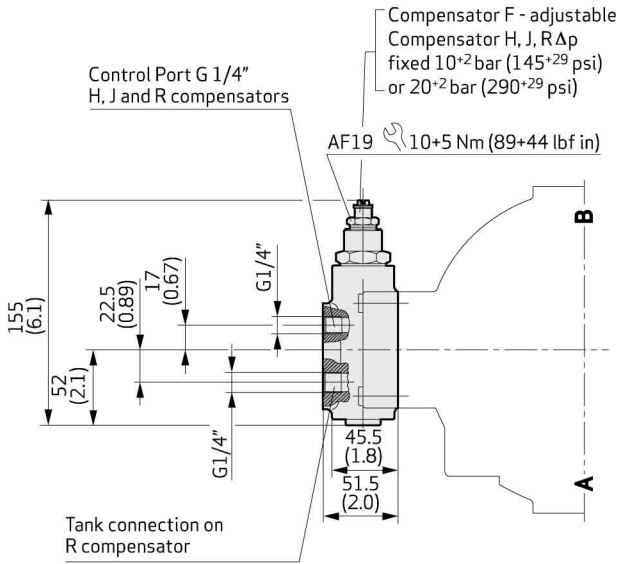

RKP 63/80/100

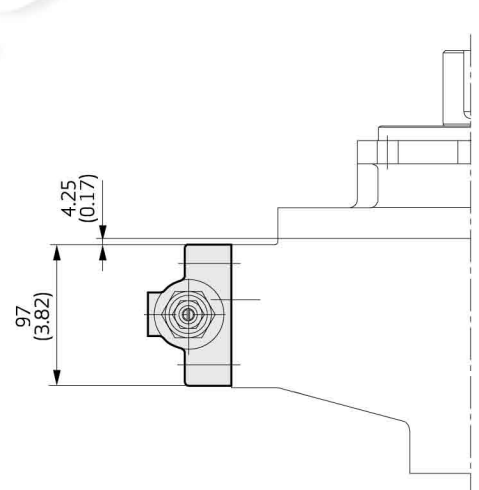
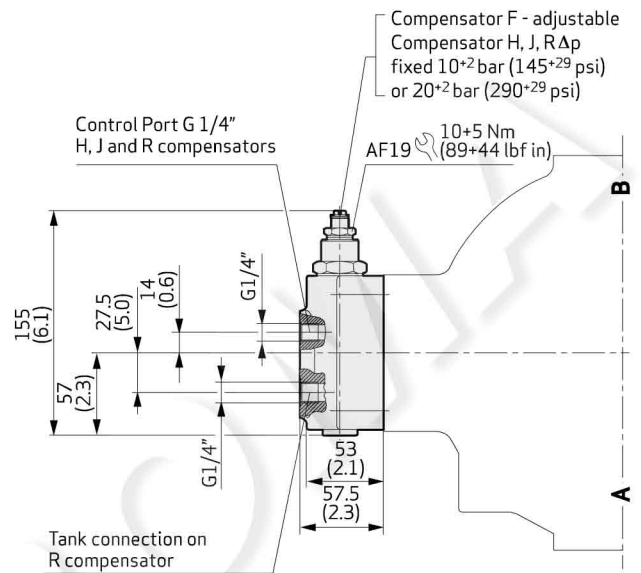

MODEL CODE

Selection

Standard version: Operating pressure 280 bar (4,000 psi), single pump, clockwise rotation, mineral oil operation standard drive flange, metric, key shaft

Compensator	Displacement cm ³ /rev	Model code	Order number
Pressure compensator, adjustable from 80 to 350 bar (1,160 to 5,000 psi)	19	HPR18A1 RKP019SM28F2Z00	D951-2079-10
	32	HPR18A1 RKP032KM28F2Z00	D952-2007-10
	45	HPR18A1 RKP045KM28F2Z00	D953-2015-10
	63	HPR18A1 RKP063KM28F2Z00	D954-2003-10
	80	HPR18A1 RKP080KM28F2Z00	D955-2003-10
	100	HPR18A1 RKP100TM28F2Z00	D956-2003-10
	140	HPR18A7 RKP140TM28F2Z00	D957-2075-10
Pressure compenstor, hydraulically controlled	19	HPR18A1 RKP019SM28H1Z00	D951-2009-10
	32	HPR18A1 RKP032KM28H1Z00	D952-2009-10
	45	HPR18A1 RKP045KM28H1Z00	D953-2017-10
	63	HPR18A1 RKP063KM28H1Z00	D954-2013-10
	80	HPR18A1 RKP080KM28H1Z00	D955-2013-10
	100	HPR18A1 RKP100TM28H1Z00	D956-2011-10
	140	-	-
Combined pressure and flow compensator	19	HPR18A1 RKP019SM28J1Z00	D951-2007-10
	32	HPR18A1 RKP032KM28J1Z00	D952-2001-10
	45	HPR18A1 RKP045KM28J1Z00	D953-2001-10
	63	HPR18A1 RKP063KM28J1Z00	D954-2011-10
	80	HPR18A1 RKP080KM28J1Z00	D955-2017-10
	100	HPR18A1 RKP100TM28J1Z00	D956-2017-10
	140	-	-
RKP-D (digital pQ control)	19	HPR18A1 RKP019SM28D1Z00	D951-2013-10
	32	HPR18A1 RKP032KM28D1Z00	D952-2005-10
	45	HPR18A1 RKP045KM28D1Z00	D953-2059-10
	63	HPR18A1 RKP063KM28D1Z00	D954-2075-10
	80	HPR18A1 RKP080KM28D1Z00	D955-2031-10
	100	HPR18A1 RKP100TM28D1Z00	D956-2039-10
	140	HPR18A7 RKP140TM28D1Z00	D957-2039-10

MODEL CODE

The Model Code Describes Pump Options

There are design interfaces (flange, shaft end and ports), hydraulic parameters (volume flow, operating pressure and hydraulic fluid) and control options.

Examples

Position number	1		2	3	4			
Drive	HP	-	R	18	B1	-		

Position number	5	6	7	8	9	10	11	12
Pump 1	RKP	100	T	M	28	D1	Z	00
Pump 2	RKP	063	K	M	28	D2	Z	00
Pump 3	AZP	008	R	M	28	TP	0	00

	Drive			Radial Piston Pump								
Position	1	2	3	4	5	6	7	8	9	10	11	12
Code	HP	R	18	B1	RKP	100	T	M	28	D1	Z	00
					Radial Piston Pump							
		5	6	7	8	9	10	11	12			
		RKP	063	K	M	28	D2	Z	00			
					Additional Pump Stage							
		5	6	7	8	9	10	11	12			
		AZP	008	R	M	28	TP	0	00			

MODEL CODE

Position	Code	Radial Piston Pump
1	HP HK HZ	Code Hydraulic Pump Explosion protection pump (ATEX) Pump with special features
2	R L	Rotations Clockwise, looking at drive shaft Counterclockwise, looking at drive shaft
3	18	Speed Maximum speed for low noise operation or rated speed for power controlled pumps, e. g. 18 => n = 1,800 min ⁻¹
4	A1 B1 A7 B7 C3 D3 A5 C6 XX	Drive flange Straight key according to DIN 6885, metric round flange (not for RKP 140 and RKP 250) Spline according to DIN 5482, metric round flange (not for RKP 140 and RKP 250) Straight key according to DIN 6885, 4 holes ISO flange according to ISO 3019-2 (metric) Spline according to DIN 5480, 4 holes ISO flange according to ISO 3019-2 (metric) Straight key according to SAE 744 C, 2/4 holes SAE-flange according to ISO 3019-1 (inch) Spline according to SAE 744 C (ISO 3019-1), 2/4 holes SAE-flange according to ISO 3019-1 (inch) Straight key according to DIN 6885, metric round flange for polyurethane foam Straight key according to SAE 744 C, 2/4 holes SAE-flange according to ISO 3019-1 (inch) for polyurethane foam Intermediate flange RKP/RKP
5	RKP AZP DS1	Pump type Radial piston pump, variable displacement Moog gear pump with SAE-A and SAE-B flange Attachment of other pumps Heavy-duty through-drive for RKP attachment and adapter flange for SAE-A, SAE-B or SAE-C
6	019 032 045 063 080 100 140 250 005 008 011 016 019 023 031 033 044 050	Displacement RKP 19 cm ³ /rev 32 cm ³ /rev 45 cm ³ /rev 63 cm ³ /rev 80 cm ³ /rev 100 cm ³ /rev 140 cm ³ /rev 250 cm ³ /rev Displacement and attachment flange of Moog gear pumps (AZP) 5 cm ³ /rev SAE-A 8 cm ³ /rev SAE-A 11 cm ³ /rev SAE-A 16 cm ³ /rev SAE-A 19 cm ³ /rev SAE-A 23 cm ³ /rev SAE-A 31 cm ³ /rev SAE-A 33 cm ³ /rev SAE-B 44 cm ³ /rev SAE-B 50 cm ³ /rev SAE-B
7	K T T S H R	Pump ports Medium pressure series (to 280 bar (4,000 psi)) sizes 32, 45, 63 and 80 cm³/rev Medium pressure series (to 280 bar (4,000 psi)) sizes 100 cm³/rev and 140 cm³/rev High pressure series (to 350 bar (5,000 psi)) sizes 32, 63, 80 and 250 cm ³ /rev Medium pressure series (to 280 bar (4,000 psi)) size 19 cm³/rev High pressure series (to 350 bar (5,000 psi)) size 19 cm ³ /rev German 4 bolt flange (only for gear pumps)

¹⁾ See catalog RKP with digital control (RKP-D)
Options may increase price. Not all combinations may be available.
Note: Preferred configurations are highlighted. Subject to change.

MODEL CODE

Position	Code	Radial Piston Pump
8	M A B C D E	Operating fluid Mineral Oil HFA (oil in water) HFB (oil in water) HFC (water glycol) HFD (synthetic esther) Cutting Emulsion
9	28 35	Operating pressure Maximum operating pressure e.g., 28 => 280 bar (4,000 psi) Maximum operating pressure e.g., 35 => 350 bar (5,000 psi)
10	B1 C1 D1 ¹⁾ D2 ¹⁾ D3 ¹⁾ D4 ¹⁾ D5 ¹⁾ D6 ¹⁾ D7 ¹⁾ D8 ¹⁾ F1 F2 G1 G2 H1 H2 J1 J2 N1 R1 S1 S2 S3 TP	Control/Compensators Mechanical stroke adjustment (V = constant) Servo control RKP-D (electro-hydraulic control with digital on-board electronics), internal pressure supply RKP-D (electro-hydraulic control with digital on-board electronics), external pressure supply RKP-D with external pressure supply, useable for hybrid operation RKP-D with internal pressure supply, useable for hybrid operation RKP-D with internal pressure supply useable for master/slave operation RKP-D with external pressure supply useable for master/slave operation RKP-D with external pressure supply useable for master/slave and hybrid operation RKP-D with internal pressure supply useable for master/slave and hybrid operation For RKP-D with EtherCAT only the options D5, D6, D7, D8 are available Pressure compensator, adjustable from 30 to 105 bar (435 to 1,523 psi) Pressure compensator, adjustable from 80 to 350 bar (1,160 to 5,000 psi) Pressure compensator, adjustable and lockable, from 30 to 105 bar (435 to 1,523 psi) Pressure compensator, adjustable and lockable, from 80 to 350 bar (1,160 to 5,000 psi) Pressure compensator, hydraulically controlled Mooring control Combined pressure and flow compensator $\Delta p = 10$ bar (145 psi) Combined pressure and flow compensator $\Delta p = 20$ bar (290 psi) Dual-displacement Combined pressure and flow compensator with P-T control notch Constant horsepower control Constant horsepower control with pressure-flow limitation, $\Delta p = 10$ bar (145 psi) Constant horsepower control with pressure-flow limitation, $\Delta p = 20$ bar (290 psi) Gear pump
11	Z Y 0	Additional equipment No Accessories Maximum flow limiter Only at gear pump
12	00 01 A0 04 05 07 11 15 18 22 30 37 45 55 75 05 to 50	Additional information For Compensators D1 to D8 CAN bus, actual value output 4 to 20 mA CAN bus, actual value output 2 to 10 V EtherCAT bus, actual value output 4 to 20 mA For compensators S1, S2, S3 power consumption for speed 1,450 or 1,750 min⁻¹ (other speed upon request) 4 kW (RKP 32) 5,5 kW (RKP 32, 45) 7,5 kW (RKP 32, 45, 63) 11 kW (RKP 32, 45, 63, 80) 15 kW (RKP 32, 45, 63, 80, 100) 18 kW (RKP 45, 63, 80, 100) 22 kW (RKP 63, 80, 100) 30 kW (RKP 63, 80, 100, 140) 37 kW (RKP 80, 100, 140) 45 kW (RKP 80, 100, 140) 55 kW (RKP 140) 75 kW (RKP 140) For tandem gear pumps: Displacement of the 2nd gear pump 5 to 50 cm ³ /rev

¹⁾ See [catalog](#) RKP with digital control (RKP-D)
Options may increase price. Not all combinations may be available.
Note: Preferred configurations are highlighted. Subject to change.