

Introduction

Oil Control range dedicated to garbage compactor trucks includes a series of multifunctional blocks providing the control of the typical functions of this application such as the packing cycle performed by carrier and packer and the movements of ejector plate. Oil Control range of blocks provides solutions also for the rear hopper, the bin hoist or other specific applications.

Packing cycle

The valves described below are fitted on the cylinders controlling the packing cycle. The sequence starts with the packer blade opening and the carrier lowering. The packing is achieved by closing the packer blade and rising the carrier.

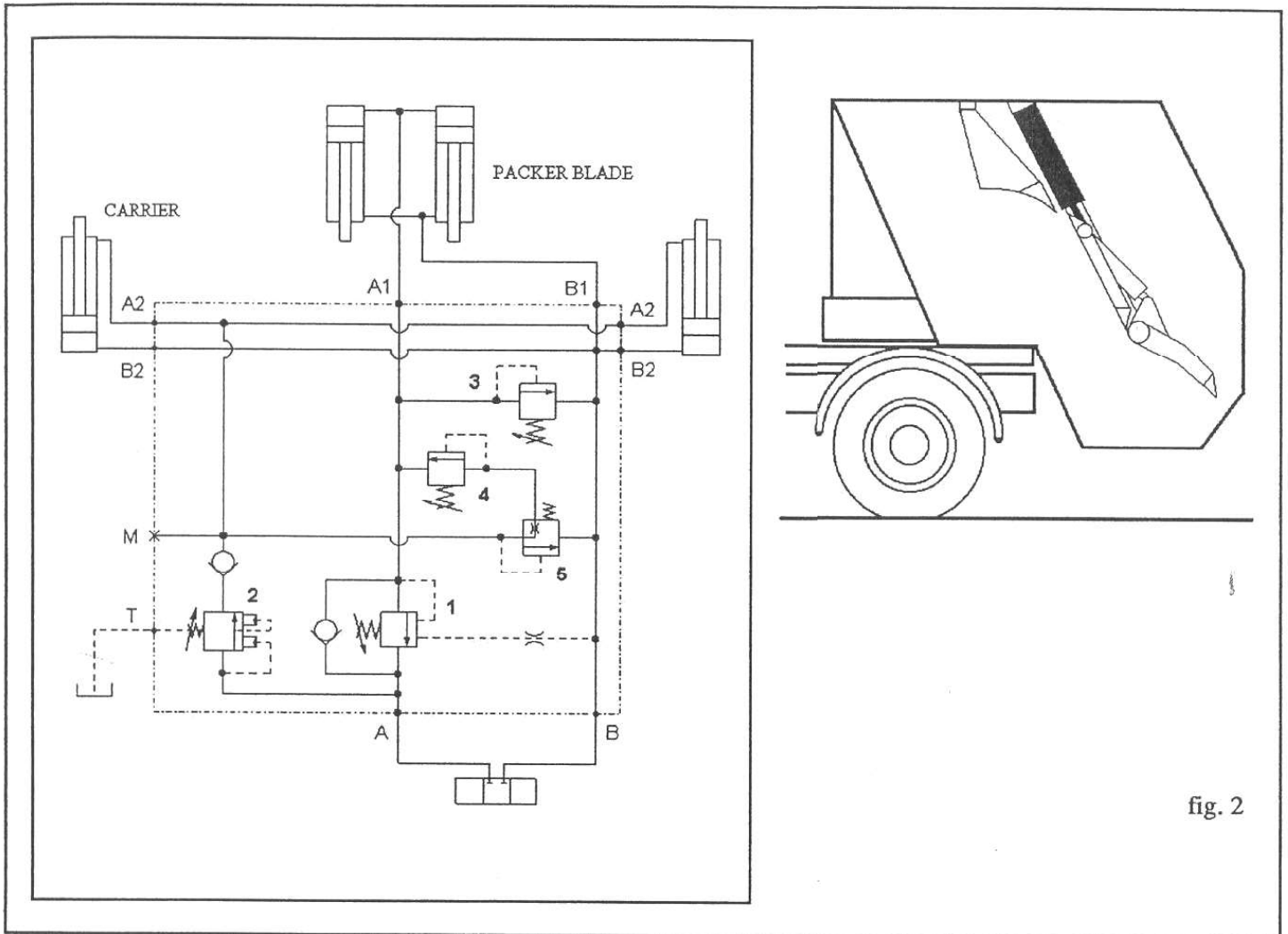

fig. 2

They can be manufactured in 2 versions :

- Type A: it is studied to be fitted on refuse collectors where the packing (actually, the rising of the carrier) is made by sending oil to the full bore side of the cylinder¹ (fig. 1).
- Type B: it is studied to be fitted on refuse collectors where the packing is made by sending oil to the rod side of the cylinder. It provides oil regeneration during the lowering of the carrier in order to increase the speed (fig. 2).

¹ This lay out, in spite of being less compact, enables to exploit the full force generated by the cylinder.

Principles of operation

- Blade opening: oil flows from B to B1 and contemporarily pilots open the overcentre valve (1) in order to allow a controlled oil outlet from the bore side (A1 port) to tank.
 - Carrier lowering:
 - * Type A: when the cylinder controlling the blade gets the stroke end, the pressure grows until piloting open the overcentre valve (4) in order to allow the oil from the bore side (A2 port) to flow back to tank.
 - * Type B: when the cylinder controlling the blade gets the stroke end, the pressure grows until opening the relief valve (4) and allows the opening of the logic element (5) so that oil coming from the rod side is re-injected into the bore side.
 - Blade closing: once the directional valve is switched to the opposite position², oil flows from A to A1.
 - Carrier rising: when the cylinder controlling the blade gets the stroke end, the pressure grows until opening the sequence kick-down valve (2) in order to allow oil from A to A2. The kick-down feature guarantees that the pressure of the system is the one requested by the secondary actuator³.
- The check valve in line with the overcentre valve (1) guarantees the blade to keep the position. The relief valve (3) prevents from any breaking due to possible overload.

² Solenoid or pneumatic controlled directional valves makes the cycle semi-automatic or completely automatic.

³ In the majority of the cycles the working pressure of the carrier cylinders is lower than the setting of the kick down valve.

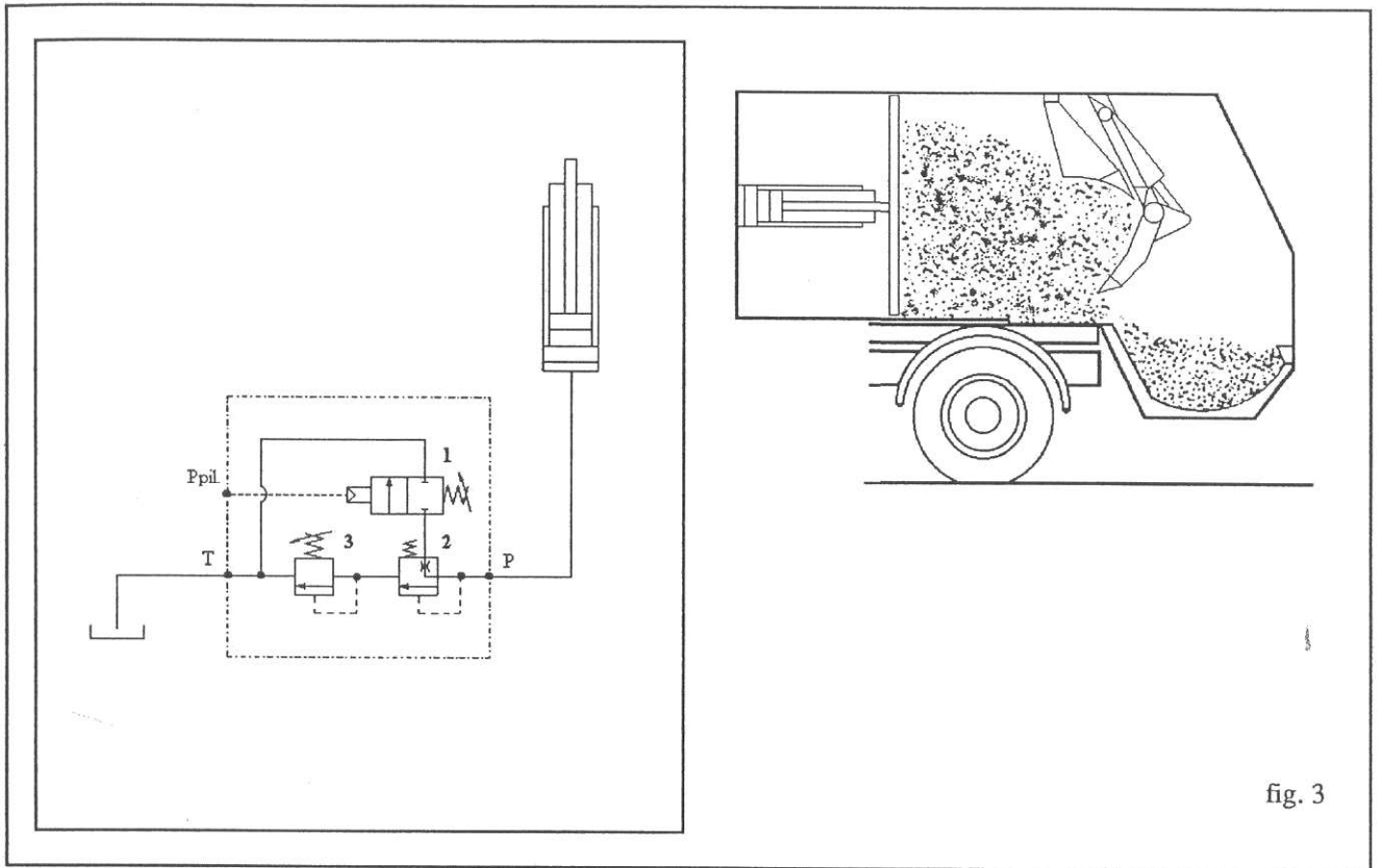

fig. 3

Ejector plate

The valve described below is fitted on the telescopic cylinder of the ejector plate in order to provide its gradual retraction each time the packing cycle increases the load (fig. 3).

Principles of operation:

The pressure of the line controlling the blade closing and the carrier rising pilots open valve (1) and allows the logic element (2) to open. The relief valve (3) prevents an over-retraction of the plate and guarantees the packing of the load. See also the annexed example of a complete hydraulic scheme.

DENOMINAZIONE VALVOLA
VALVE DENOMINATION

CODICE D'ORDINAZIONE
ORDERING CODE

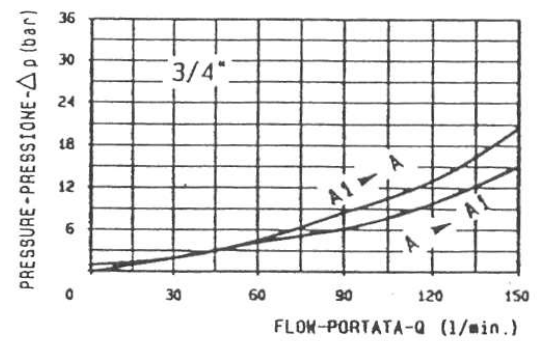
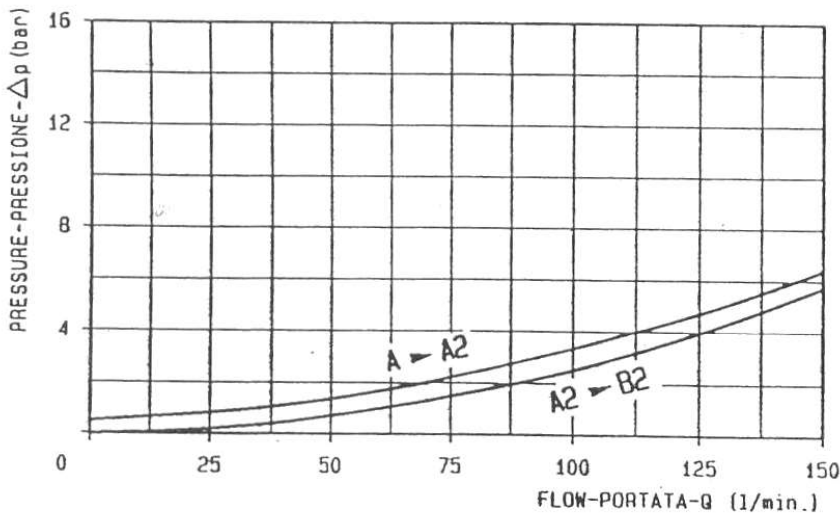
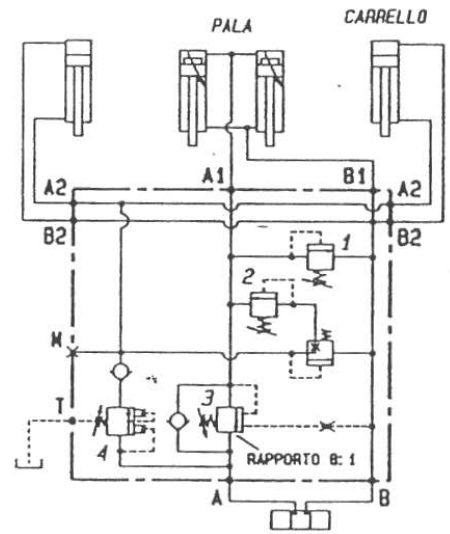
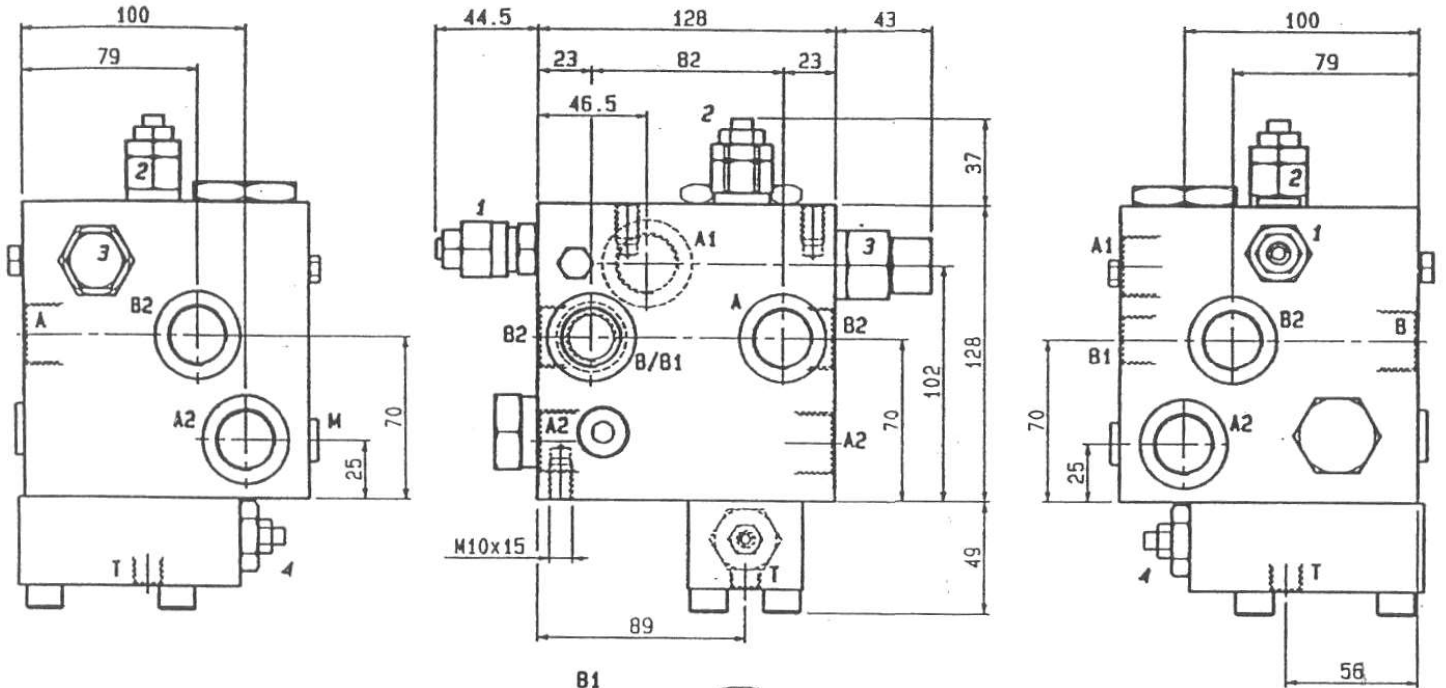

RIFERIMENTO VALVOLA	TARATURA bar (Q=5 l/1')	INCREMENTO PRESSIONE bar/giro vite	ATTACCHI		PRESTAZIONI	
N°1 041118039935	280	82	"A"-"A1"-"A2"-"B"-"B2"	3/4" BSPP	PORTATA ALL'INGRESSO "A"-"B" MAX	150 l/min
N°2 041122039920	50	48	"B1"	1/2" BSPP	PRESSIONE DI LAVORO "A"-"B"-"B1"-"A2"-"B2"	250 bar
N°3	230	201	"M" - "T"	1/4" BSPP	PRESSIONE DI LAVORO "A1"	300 bar
N°4	175	46				

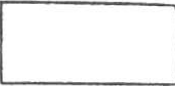

VMS-VS-12

07010217000000A

DENOMINAZIONE VALVOLA
VALVE DENOMINATION

CODICE D'ORDINAZIONE
ORDERING CODE

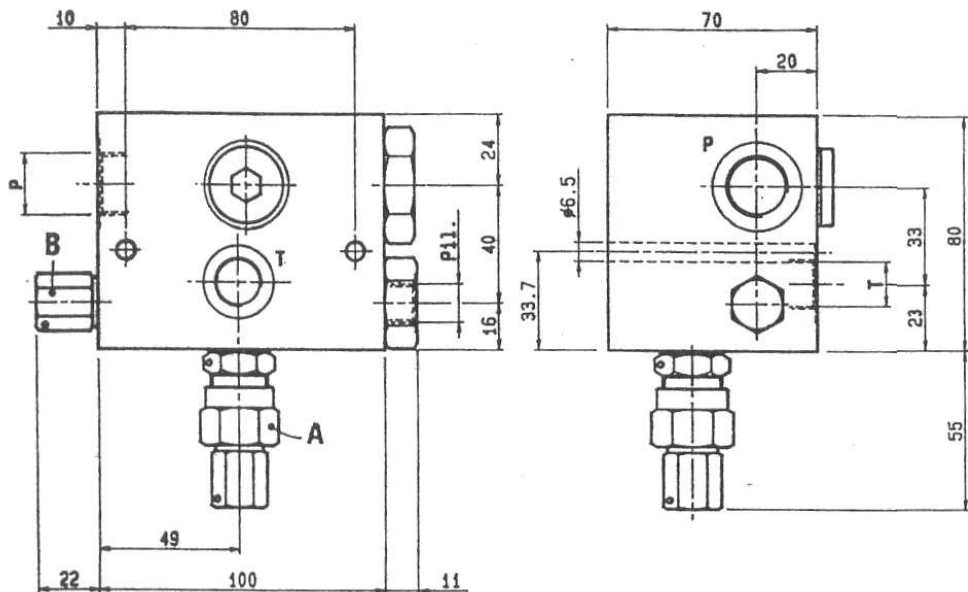

Con fori per piombatura a filo
With holes for wire-locking

Pressione di lavoro
max 350 bar

Portata max della valvola B
30 l/min

Peso Kg 1,9

Max working pressure
350 bar

Flow max of valve B
30 l/min

Weight Kg 1,9

REGOLAZIONI ADJUSTMENTS

vite interna
esagono incassato
leakproof inner hex.
socket screw



VALVOLA VALVE	MOLLE - SPRINGS				
	Campo taratura min-max bar Adj.press. range bar	Incremento pressione bar/giro vite Pressure increase bar/turn	Taratura standard bar (0-5 1/1') Std.setting bar (made at 5 1/1')	Codice ordinazione Ordering code	Colore Colour
A	10-50	12	40	03.51.01.077	nero black
B	50-210	47	180	03.51.01.075	verde green

	ATTACCHI / PORT SIZE		
	P	T	P11
	1/2" BSPP	3/8" BSPP	1/4" BSPP

DENOMINAZIONE VALVOLA
VALVE DENOMINATION

CODICE D'ORDINAZIONE
ORDERING CODE

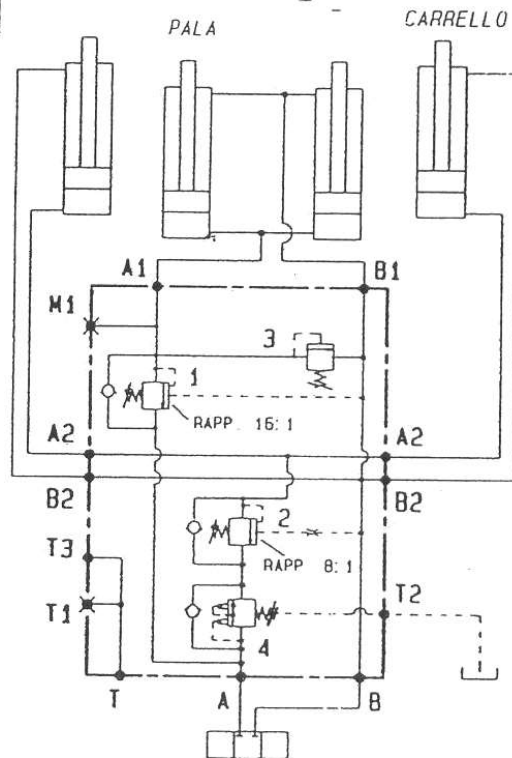
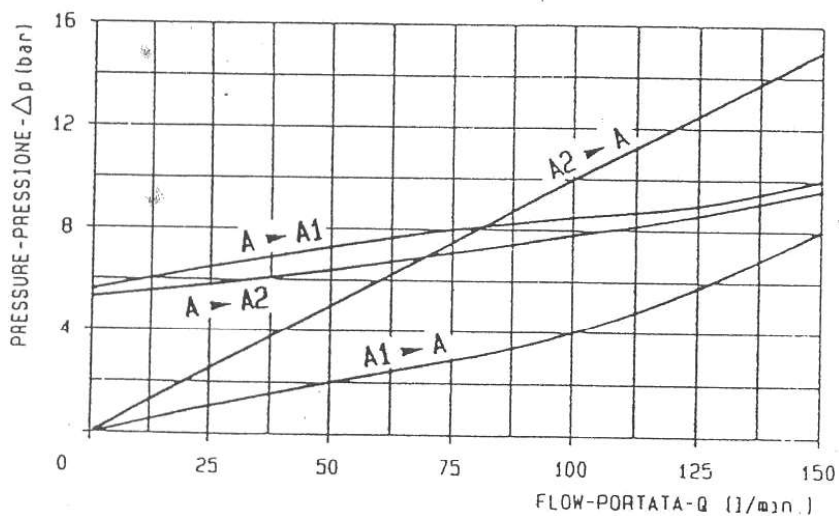
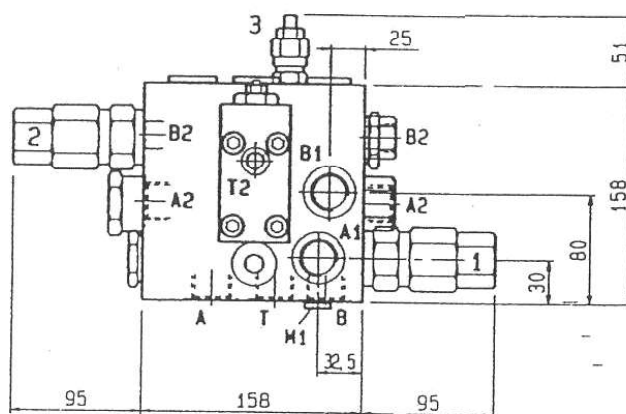
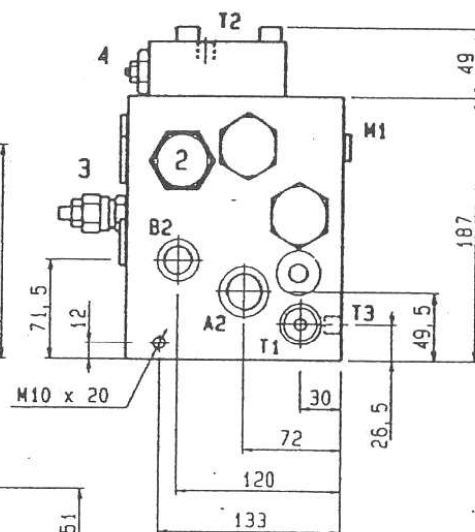
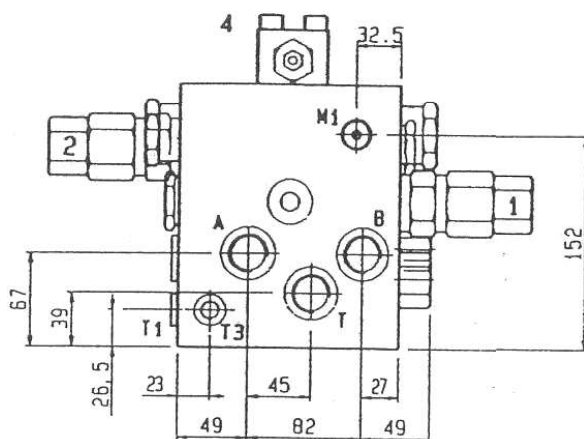
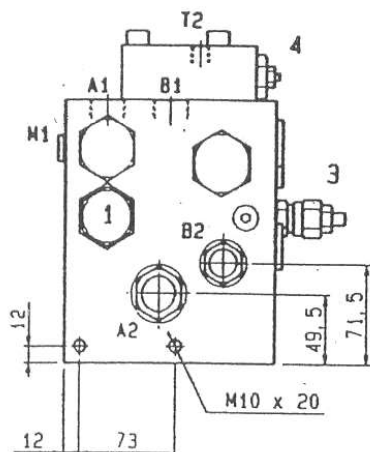

RIFERIMENTO VALVOLA	TARATURA bar (Q=5 l/min)	INCREMENTO PRESSIONE bar/giro vite	ATTACCHI		PRESTAZIONI	
N° 1	300	74	"A" - "A1" - "A2" - "B" - "B1" - "T"	3/4" BSPP	PORTATA ALL'INGRESSO "A" - "B" MAX	150 l/min
N° 2	350	64	"B2" - "T1"	1/2" BSPP	PRESSIONE DI LAVORO "A" - "B" - "B1" - "A2" - "B2"	250 bar
N° 3 041118039935	280	82	"M1" - "T2" - "T3"	1/4" BSPP	PRESSIONE DI LAVORO "A1"	300 bar
N° 4	175	46				