

Part number:

006-10598

HYDROMA

HYDRAULICKÉ SYSTÉMY

**HIDROMA
SYSTEMS**

UKŁADY HYDRAULICZNE

HYDROMA

ГИДРАВЛИЧЕСКИЕ СИСТЕМЫ

1/2

RE 18309-57/07.12

Replaces: RE 18309-57/04.10

Flow divider, combiner

DRF

0M.51.03.90.04 - Z

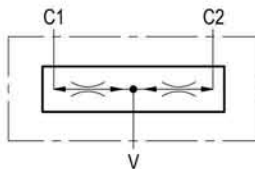
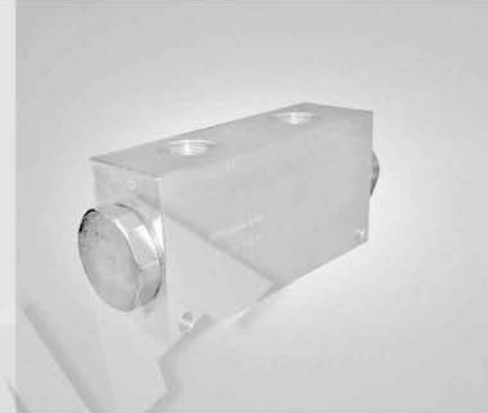

Description

This valve gives division of input flow from V to C1-C2, and re-combines flows in reverse direction from C1-C2 to V. The ratio between the flows through C1 and through C2 is maintained constant (typically 50% / 50%) over a wide range of pressure variations and of pressure imbalance in order to synchronize the motion of 2 actuators in both forward and reverse directions. In flow division mode, should either C1 or C2 be blocked, approximately 1→2% of the available flow can be forced through the port still open.

Performance

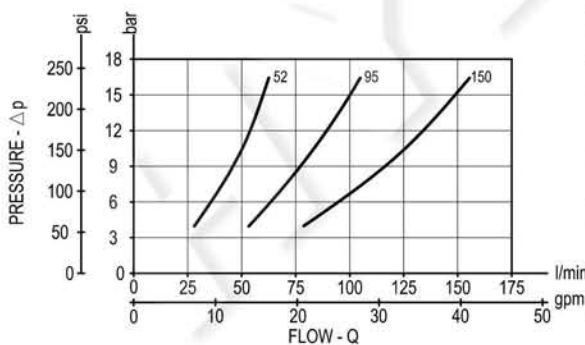

Technical data

Hydraulic

Operating pressure bar (psi) up to 210 (3000)

Flow division ratio: 50% - 50%

For any chosen inlet flow capacity (refer to table Z), the slippage, or the difference from theoretical value between the divided flows, depends from the inlet flow, and is lowest in the top portion of the selected range: generally it never exceeds $\pm 3\%$.

General

Manifold material Aluminium

Note: aluminium bodies are often strong enough for operating pressures exceeding 210 bar (3000 psi), depending from the fatigue life expected in the specific application. If in doubt, consult our Service Network.

Weight kg (lbs) 2.2 (4.9)

Fluid temperature range °C (°F) between -30 (-22) and +100 (212)

Other technical data see data sheet RE 18350-50

Note: for applications outside these parameters, please consult us.

Dimensions

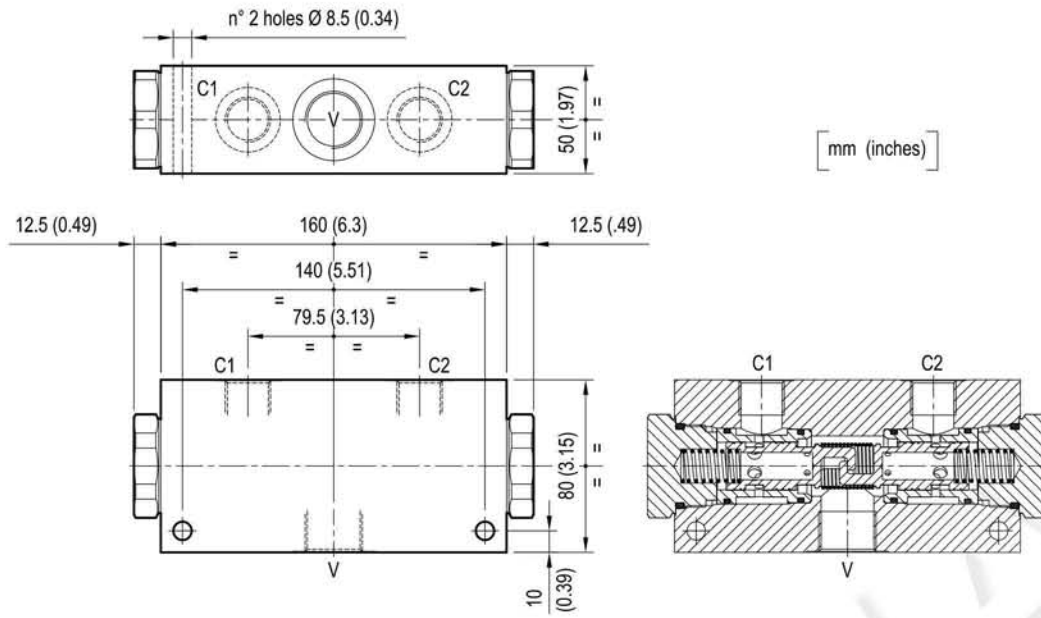

Ordering code

OM.51.03.90 04 Z

Flow divider, combiner

Port sizes	V	C1 - C2
	G 3/4	G 1/2

INLET CAPACITY

= 52	28 to 55 l/min (7.4 to 14.53 gpm)
= 95	56 to 95 l/min (14.8 to 25.1 gpm)
= 150	90 to 150 l/min (27.78 to 39.63 gpm)

Type	Material number
OM510390045200A	R930001930
OM510390049500A	R930001889
OM510390041500A	R930005816

Type	Material number