

Part number:

HYDROMA

HYDRAULICKÉ SYSTÉMY

**HIDROMA
SISTEMS**

UKŁADY HYDRAULICZNE

HYDROMA

ГИДРАВЛИЧЕСКИЕ СИСТЕМЫ

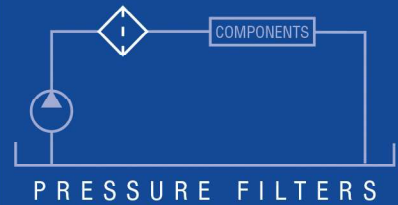

PC5

MATERIALS

Head:
Cast iron

Bowl:
Steel

Bypass valve:
Steel

Seals:
NBR Nitrile
(FKM - on request fluoroelastomer)

Indicator housing:
Brass

PRESSURE (ISO 10771)

Max working:
38 MPa (380 bar)

Collapse, differential
for the filter element (ISO 2941):
series standard: 2 MPa (25 bar)

BYPASS VALVE

Setting:
600 kPa (6 bar) \pm 10%
340 kPa (3,4 bar) \pm 10%

WORKING TEMPERATURE

From -25° to +125° C

COMPATIBILITY (ISO 2943)

Full with fluids: HH-HL-HM-HV-HTG
(according to ISO 6743/4)
For fluids different than the above
mentioned, please contact our Sales
Department.

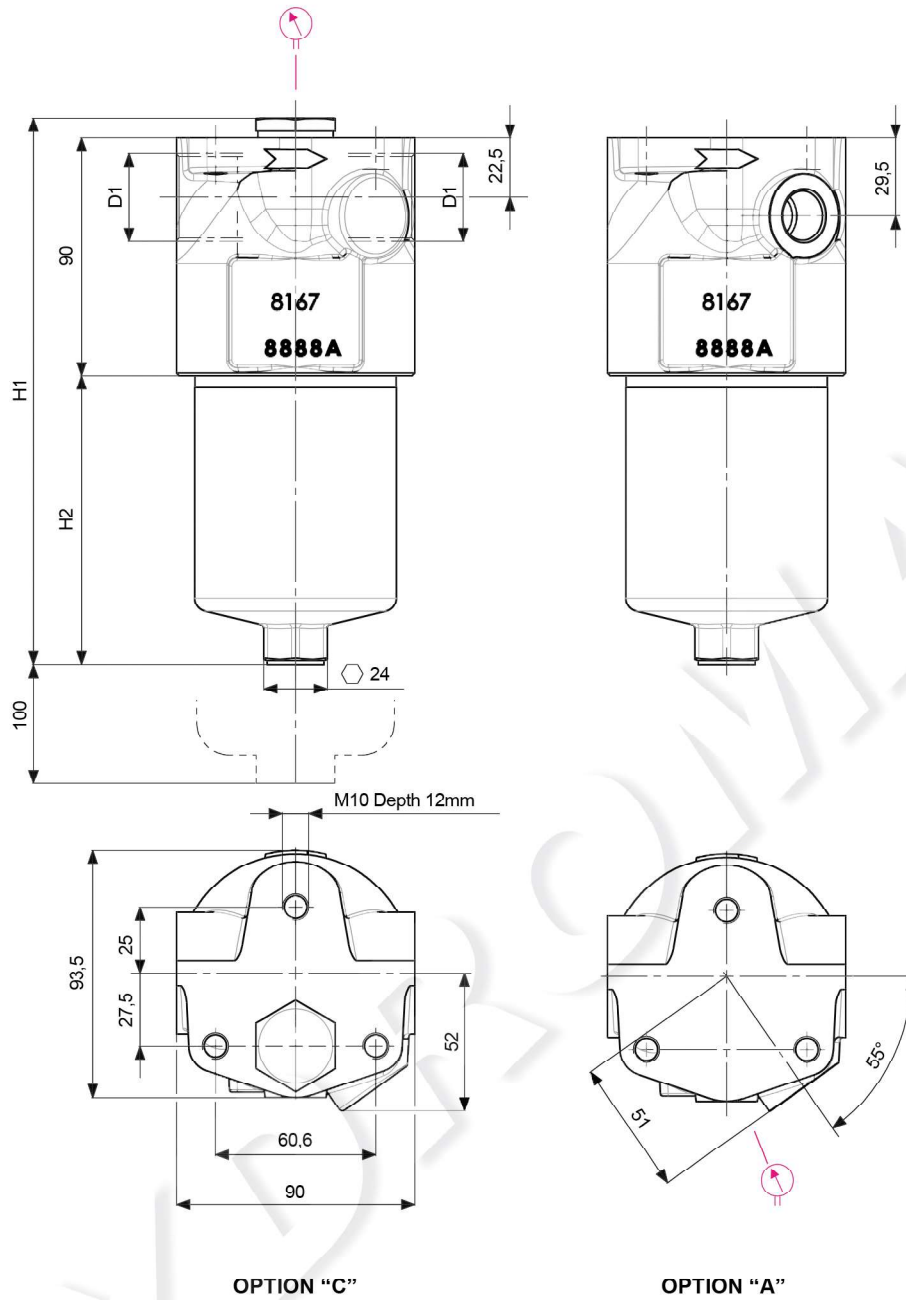

FILTER HOUSING

	D1	H1	H2	kg
FPC51	M22x1,5 - 1/2" - 3/4" - 1" BSP or SAE thread	206,5	109	4,2
FPC53	M22x1,5 - 1/2" - 3/4" - 1" BSP or SAE thread	254,5	157	4,7
FPC55	M22x1,5 - 1/2" - 3/4" - 1" BSP or SAE thread	307	209,5	5,3

TYPE					
F = FILTER COMPLETE		F	F	F	
B = FILTER HOUSING		B	B	B	ELEMENT
P	C	FAMILY SIZE & LENGTH			FAMILY SIZE & LENGTH
		51	53	55	
PORT TYPE					
B = BSP - thread		B	B	B	
M = Metric thread (only M22x1,5)		M	M	M	
S = SAE thread		S	S	S	
PORT SIZE					
04 = 1/2"		04	04	04	
06 = 3/4"		06	06	06	
08 = 1"		08	08	08	
BYPASS VALVE					
W = without		W	W	W	
C = 600 kPa (6 bar)		C	C	C	
D = 350 kPa (3,5 bar)		D	D	D	
SEALS					SEALS
N = NBR Nitrile		N	N	N	N = NBR
F = FKM Fluoroelastomer		F	F	F	F = FKM
FILTER MEDIA					FILTER MEDIA
FA = fiber 5 μm _e β>1.000 Δp 2 MPa (20 bar)		FA	FA	FA	FA = fib.5μm _e 20 bar
FB = fiber 7 μm _e β>1.000 Δp 2 MPa (20 bar)		FB	FB	FB	FB = fib.7μm _e 20 bar
FC = fiber 12 μm _e β>1.000 Δp 2 MPa (20 bar)		FC	FC	FC	FC = fib.12μm _e 20 bar
FD = fiber 21 μm _e β>1.000 Δp 2 MPa (20 bar)		FD	FD	FD	FD = fib.21μm _e 20 bar
FS = fiber 16 μm _e β>1.000 Δp 2 MPa (20 bar)		FS	FS	FS	FS = fib.16μm _e 20 bar
CC = cellulose 10 μm β>2 Δp 2 MPa (20 bar)		CC	CC	CC	CC = cel.10μm _e 20 bar
CD = cellulose 25 μm β>2 Δp 2 MPa (20 bar)		CD	CD	CD	CD = cel.25μm _e 20 bar
CLOGGING INDICATOR					
00 = without		00	00	00	
03 = port. plugged		03	03	03	
5E = visual differential 500 kPa (5 bar)		5E	5E	5E	
6E = electrical differential 500 kPa (5 bar)		6E	6E	6E	
7E = indicator 6E with LED		7E	7E	7E	
XE = electrical differential N.O. 500 kPa (5 bar)		XE	XE	XE	
XD = electrical differential N.O. 240 kPa (2,4 bar)		XD	XD	XD	
XL = electrical differential N.C. 300 kPa (3 bar)		XL	XL	XL	
XG = electrical differential N.C. 340 kPa (3,4 bar)		XG	XG	XG	
T2 = elect. diff. 500 kPa (5 bar) with thermostat 30°C		T2	T2	T2	
ACCESSORIES					
W = without accessory		W	W	W	
A = lateral indicator port (see PWG)		A	A	A	
C = indicator port on the top (see PWG)		C	C	C	

When the filter is ordered with FKM seals, the first digit of the indicator code is a letter (please see page 182 - 183).

FILTER ELEMENT

	A	B	C	kg media F+	kg media C+
EPC51	56,5	27	118	0,12	0,10
EPC53	56,5	27	166	0,15	0,13
EPC55	56,5	27	219	0,19	0,15

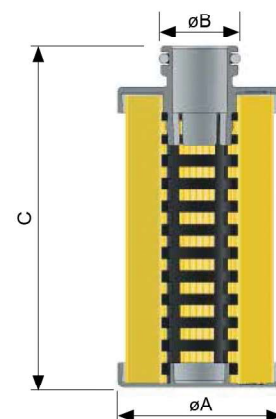

FLUID SPEED

when selecting the filter size, we suggest to consider also the max recommended fluid speed (in pressure lines normally $5 < v < 10$ m/s)

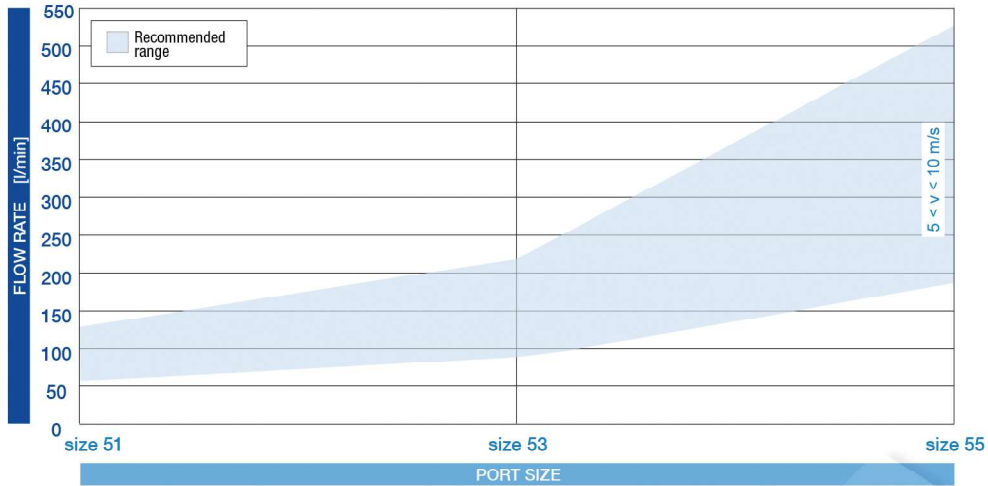

PRESSURE DROP CURVES (Δp)

The "Assembly Pressure Drop (Δp)" is obtained by adding the pressure drop values of the Filter Housing and of the Clean Filter Element corresponding to the considered Flow Rate and it must be lower than 120 kPa (1,2 bar).

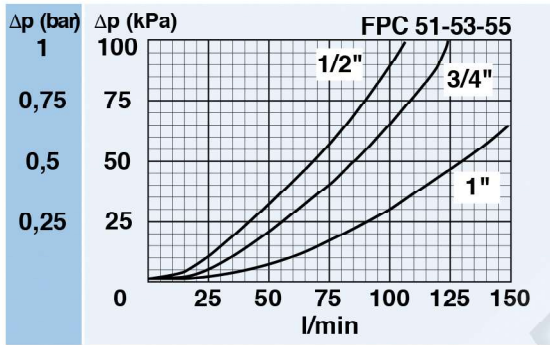

FILTER HOUSING PRESSURE DROP
(mainly depending on the port size)

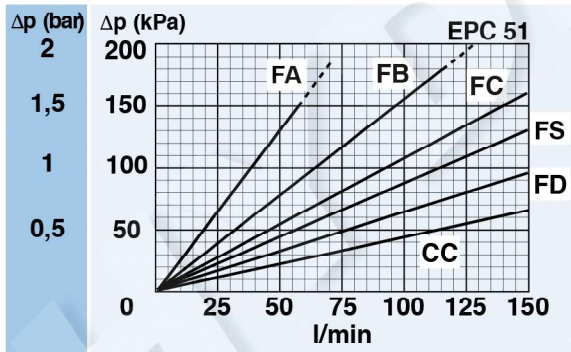

CLEAN FILTER ELEMENT PRESSURE DROP WITH F+ AND C+ MEDIA
(depending both on the internal diameter of the element and on the filter media)

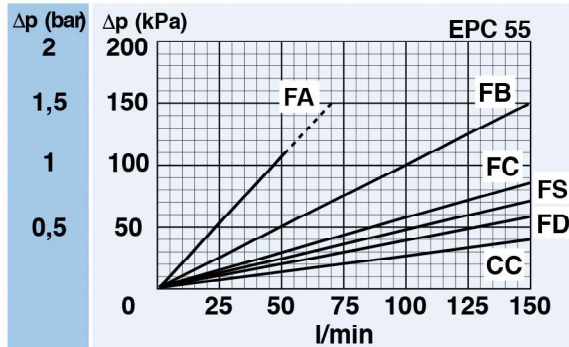
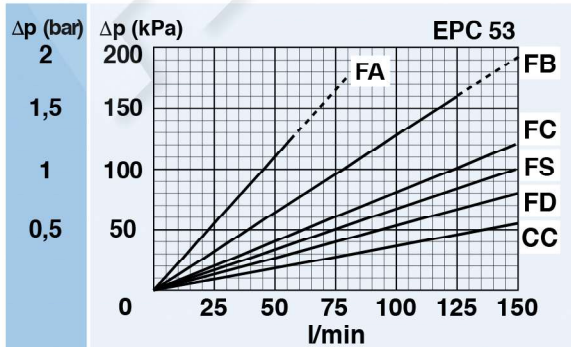

N.B. All the curves have been obtained with mineral oil having a kinematic viscosity 30 cSt and specific gravity 0,9 kg/dm³; for fluids with different features, please consider the factors described in the first part of this catalogue. All the curves are obtained from test done at the UFI HYDRAULIC DIVISION Laboratory, according to the specification ISO 3968:2005. In case of discrepancy, please check the contamination level, viscosity and features of the fluid in use.

CLOGGING INDICATOR

A visual or visual-electrical differential indicator is available as an option and allows monitoring of the element conditions, giving an exact indication of the right time to replace the element.

FILTER HOUSING

The head by high performance cast iron and the bowl by extruded steel ensure the best fatigue resistance to the working pressures.

FILTER ELEMENT

The filter element is manufactured with filter medias selected in the UFI laboratory and mechanically supported to maintain the highest performances even at high differential pressures.

SEAL GUARANTEED

A perfect O-ring seal is always ensured as it is not dependent on the tightening torque applied to the bowl.

EASY ASSEMBLING

The manifold mounting is compact and leak free.

CLOGGING INDICATOR

For further technical informations and other options see page 182-183.

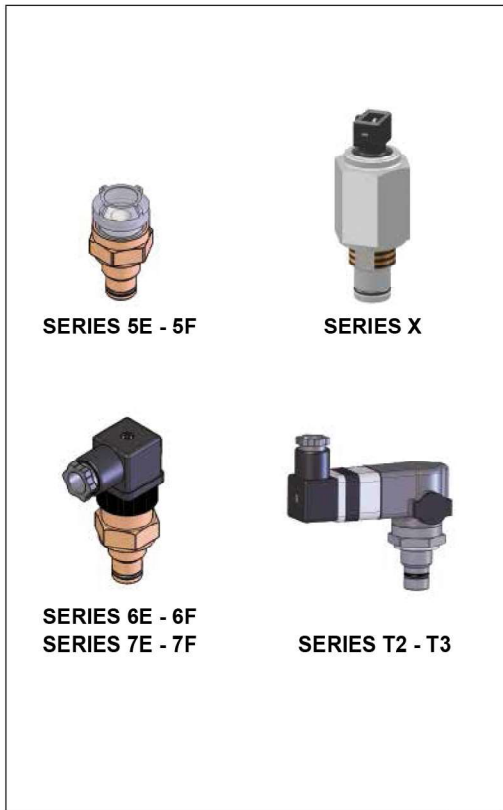

Differential



SPARE SEAL KIT

	NBR	FKM
FPC5	521.0131.2	521.0132.2

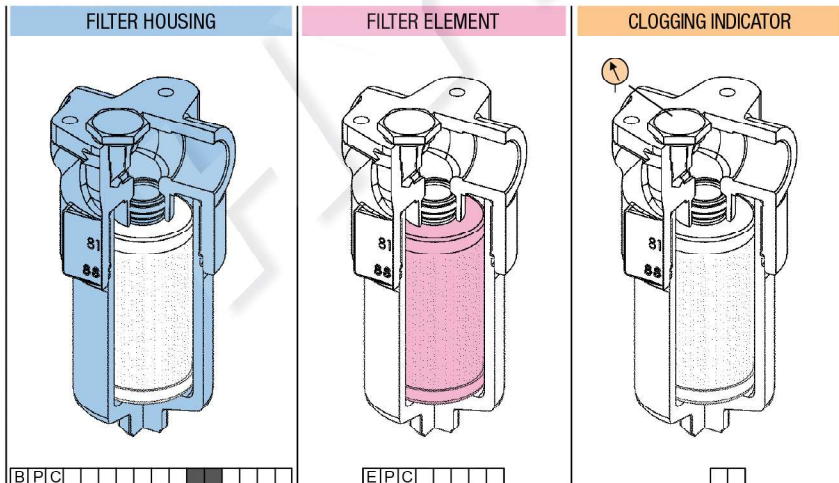

SPARE PARTS ELEMENTS

(For filling up see table "Ordering and option chart")

Technical data subject to variations without prior notice. PC5 - EN - 04/2018