

Part number:

HYDROMA

HYDRAULICKÉ SYSTÉMY

**HIDROMA
SYSTEMS**

UKŁADY HYDRAULICZNE

HYDROMA

ГИДРАВЛИЧЕСКИЕ СИСТЕМЫ



Fluid Level Gauge Fluid Level Sensor Temperature Switch

FSA / FSK / TS

up to size 381; to PN 0.5; to T = 80 °C

1. DESCRIPTION

1.1. GENERAL

FSA fluid level gauges, FSK fluid level sensors and TS temperature switches are designed to monitor and control the level of operating fluid.

The flexible product range means that many combinations are possible:

- **FSA:** Range of five evenly spaced sizes.
Visual thermometer with °C and °F scale.
Temperature gauge which measures the temperature of the operating fluid in the tank in °C. Dual scale in °C and °F available on request.
Simple, standardised mounting (FSA/K).
- **FSA-IB:** leak-free shut off of the fluid to the fluid level gauge via non-return valve
Display of the current level by simultaneously pressing the upper and lower buttons on the non-return valves
With the optional use of a thermometer, the current temperature of the fluid will also be shown.
Certified by Bureau Veritas (BV approval) and by American Bureau of Shipping (ABS approval)
- **FSK:** Four evenly spaced sizes.
Switching contact can be either type O (opens when fluid is at low level), type C (closes when fluid is at low level) or type W (dual switching unit).
Temperature gauge which measures the temperature of the operating fluid in the tank in °C and °F.
- **FSK-2SP:** Monitoring of the minimum or maximum fluid level.
Two additional alternative switching points for size 254 and above.
Option: line marking on sight tube and float.
Better visual fluid level monitoring possible with red float.
Simple, standardised mounting (FSA/K).
- **FSK-V:** Monitor the fluid level via an electrical signal
Switching point can be variably positioned
Additional alternative switching points possible
Change over switch contacts
Opens or closes at switching level
Tube made of glass
Optional, 3-pole AMP plug (super seal)
Optional line marking on inspection tube and float.
- **TS:** three nominal temperatures possible: 60 °C, 70 °C and 80 °C.
Can be easily fitted into the FSA and FSK.
Simple, standardised mounting (FSA/K).
Non-corroding surfaces.

1.2. FUNCTION

FSA

By using the FSA, the fluid level can be easily seen on the outside of the tank. The fluid enters the unit via the lower connection bore and is clearly visible in the tube. By selecting the right size, the particular fluid level can be monitored.

FSK

By using the FSK, the fluid level is monitored via an electrical switching signal. This switch signal can be used for a warning or to control the level. The fluid enters the unit via the lower connection bore and pushes a float up the tube. The float now shows the level of the fluid in the tank. If the level of the fluid drops again, the float will activate a switch contact. For the NO switch (type C) the circuit will then be closed, for the NC switch (type O) the circuit will be opened.

The special dual switching model (type W) offers two possibilities. It can be used either to close on contact or to open on contact.

TS

The TS is a very useful additional option to the FSA and FSK products. However, it also has a useful application as a separate accessory for systems.

Once fitted, the temperature sensor of the TS is surrounded by operating fluid. When the nominal temperature is reached, a contact opens and the circuit is broken.

This switching process can be used either as an alarm or to monitor the temperature.

When the temperature of the fluid drops by approx. 15 K, the circuit closes again.

1.3. APPLICATION

Fluid level gauges FSA, fluid level sensors FSK and temperature switches TS are used to monitor and control levels of operating fluid.

Areas of application are for example: Machine tools, system engineering, tanks for hydraulic, lubricating and cutting oils, and gearboxes.

1.4. NOTES

The upper viscosity limit is 2,000 mm²/s. It is not possible to combine a TS temperature switch with an FT temperature gauge.

To ensure correct functioning, pressure, viscosity and temperature specifications must be observed.

FSA/FSK

Not suitable for use with glycol or fluids containing glycol.

FSK

Depending on the fluid level of the tank, the following switching logic applies for the fluid level monitor with NC and NO contacts.

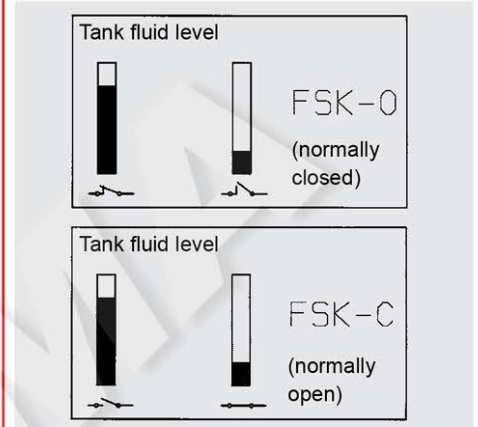

In each case the switching logic of the fluid level sensor starts with a full tank. For the NC version the switching contact opens when the fluid level drops below the switching level. Correspondingly, in the NO version, the switching contact closes when the fluid level drops below the switching level.

2. TECHNICAL CHARACTERISTICS

2.1. GENERAL

2.1.1 Designation and Symbol

Fluid level gauge FSA

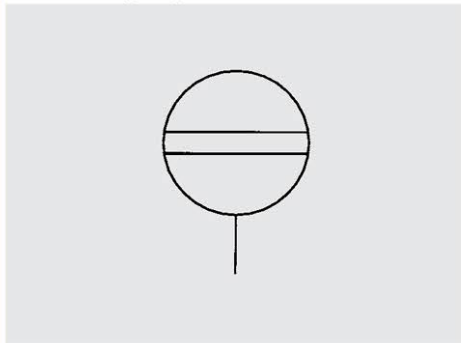

Fluid level sensor FSK

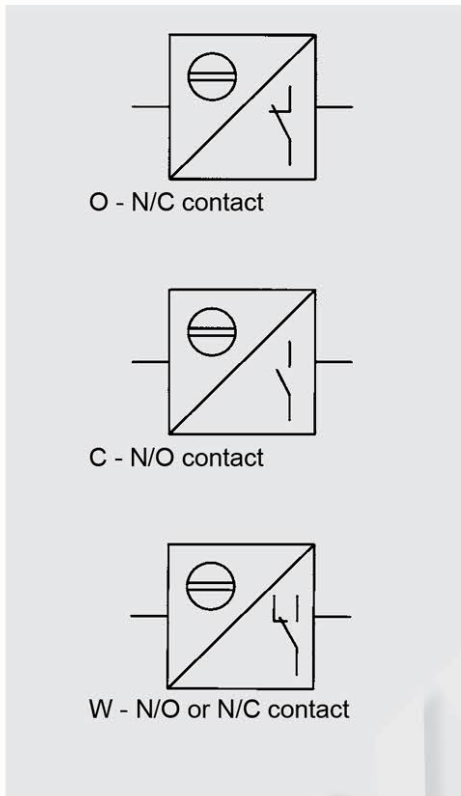

Temperature switch TS

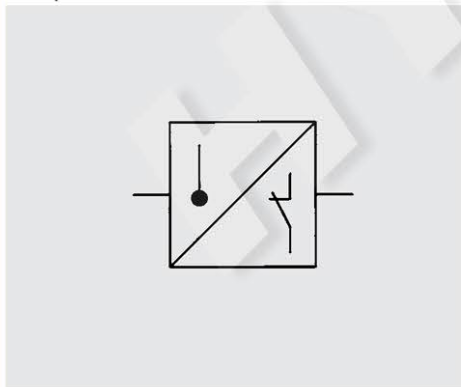

2.1.2 Model code for FSA

FSA - 076 - 2 . X / FT200 / 12 ...

(also order example)

Fluid level gauge

Nominal size

≅ Bolt centre spacing

076

127

176

254

381

Seal material

1 = NBR (Perbunan)

2 = FKM (Viton)

Series

(specified by manufacturer)

Additional thermometer function

- = no additional function

T = thermometer in display tube

FF = prepared for temperature probe

FT 200 = temperature probe 200 mm

FT 300 = temperature probe 300 mm

TS 60 = temperature switch nominal temperature 60 °C

TS 70 = temperature switch nominal temperature 70 °C

TS 80 = temperature switch nominal temperature 80 °C

TFP 100 = temperature probe -40 °C ... +150 °C

Installation conditions

Banjo bolt thread

M 12 (standard)

M 10 (not on TS)

Special models

SO2 = with glass tube, connections in aluminium and round shape

SO7 = frame, mounting bolts and nuts in stainless steel (1.4571)

SO8 = mounting bolts and nuts in stainless steel (1.4571)

SO14 = with glass tube, connections in plastic (PA)

SO19 = with green hollow ball, without contrast sheet

SO65 = FSA standard, but without mounting nuts and washers

SO67 = FSA standard, but without mounting nuts

SO79 = with side inspection window

IB BV = with non-return valve, BV approval

IB ABS = with non-return valve, ABS approval

* only for size M12

Model code FSA-IB

FSA - 254 - 2 . 0 / T / 12 S07 / S078 2 x IB

(also order example)

Fluid level gauge

Size

076

127

176

254

381

Seal material

1 = NBR (Perbunan)

2 = FKM (Viton)

Glass tube (round)

Thermometer (in the glass tube)

Thread of the M12 banjo bolt

Frame, screws and nuts made of stainless steel

2x screw ISOLATOR BOLT

Model code FSK

(also order example)

FSK - 127 - 2 . X / O / FT200 / 12 / ...**Fluid level sensor****Nominal size**

≅ Bolt centre spacing

127
176
254
381**Seal material**

2 = FKM (Viton)

Series

(specified by manufacturer)

Switching functionO = opens at the switching level
C = closes at the switching level
W = opens or closes at the switching level
(connector Z4 = standard)**Additional thermometer function**- = no additional function
FT 200 = thermometer probe 200 mm
FT 300 = thermometer probe 300 mm
TSL 60 = temperature switch nominal temperature 60 °C
TSL 70 = temperature switch nominal temperature 70 °C
TSL 80 = temperature switch nominal temperature 80 °C
TFP 100 = temperature probe -40 °C ... +150 °C**Installation conditions**Banjo bolt thread
M 12 (standard)
M 10 (not on TS)**Connector**No details = 3 pole MPM (standard)
Z4 = 4 pole Hirschmann
SEW = 4 pole M12x1 (sensor connector horizontal)
SES = 4 pole M12x1 (sensor connector vertical)
Type B = special connection to the connector plug**Model code FSK-2SP / FSK-V**

(also order example)

FSK - 127 - 1 . O / W / - / 12 / 2SP**Designation**FSK = fluid level monitor
FSKV = fluid level monitor with variable switching points**Nominal size**

≅ Bolt centre spacing

127
176
254
381**Seal material**

1 = NBR (Perbunan)

Series

(specified by manufacturer)

Switching function

W = change over, opens and closes at the switching level

Additional thermometer function

- = no additional function (standard)

Installation conditions

12 = M12 (banjo bolt thread)

Switching points2SP = 2 switching points (1 x minimum, 1 x maximum)
additional switching points on request**Connector**FSK-2SP: 5-pole M12x1 male
FSK-V: 3-pole M8x1 male

Model code TS

(also order example)

TS - 70 / X / 12**Designation**

TS - temperature switch (for FSA)

TS-L - temperature switch long (for FSK)

Nominal temperature

60 °C

70 °C

80 °C

Series

(specified by manufacturer)

Banjo bolt thread

M 12

2.1.4 Type of construction

The units are designed to be mounted directly on to the operating fluid tank.

2.1.5 Type of connection**FSA / FSK**

The unit is mounted using two banjo bolts. The connection bores can either be threaded holes or through holes (Ø 13, Ø 11).

TS

The temperature switch can be fitted to the FSA/FSK in place of the lower banjo bolt.

2.1.6 Mounting position**FSA** – vertically on the tank wall**FSK** – vertically on the tank wall (connection plug at bottom of the tank)**TS** – instead of lower banjo bolt M12 (FSA)**TS-L** – instead of lower banjo bolt M12 (FSK)**2.1.7 Weight**

FSK 127 – 0.21 kg

FSK 176 – 0.23 kg

FSK 254 – 0.26 kg

FSK 381 – 0.30 kg

FSA 076 – 0.17 kg

FSA 127 – 0.19 kg

FSA 176 – 0.21 kg

FSA 254 – 0.24 kg

FSA 381 – 0.29 kg

TS-... – 0.11 kg

TS-L-... – 0.13 kg

FT 200 – 0.03 kg

FT 300 – 0.04 kg

2.1.8 Flow direction

any

2.1.9 Ambient temperature

- 20 °C to + 80 °C

2.1.10 Materials**FSA / FSK**

- End caps and tube in high quality synthetic material
- Housing in aluminium
- Soft seals in Viton (FKM) or Perbunan (NBR)
- Bolts, nuts and washers in steel (zinc-plated)
- Plug connections in high quality synthetic material (FSK)

FSA-IB

- Housing frame made of stainless steel
- Tube made of glass

FSK-2SP

- Connectors made of aluminium / polyamide
- Frame made of aluminium
- Tube made of glass

FSK-V

- Housing frame made of stainless steel
- Connectors made of aluminium / polyamide
- Tube in glass

TS / TS-L

- Housing with temperature sensor, washer and nut in steel (zinc-plated)
- Plug connections in high quality synthetic material

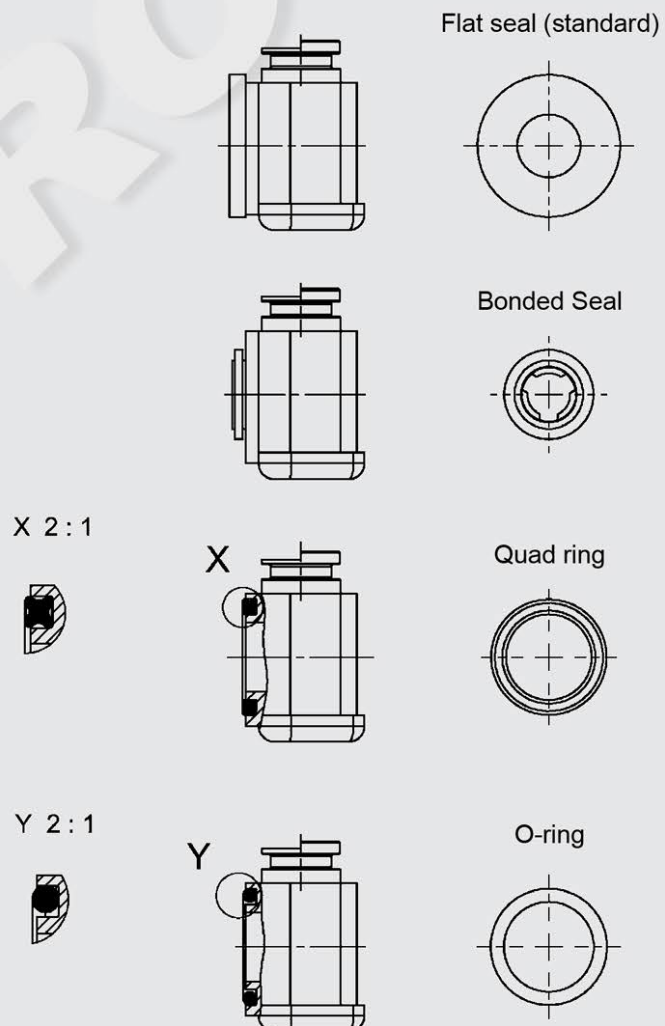
2.1.11 FSA seal types

2.2. HYDRAULIC DATA

2.2.1 Nominal pressure

max. 0.5 bar

2.2.2 Operating fluids

Mineral oil to DIN 51524 Part 1 and 2, water-oil emulsions and synthetic fluids, such as hydraulic fluids based on phosphate ester.

(other fluids on request)

2.2.3 Temperature of operating fluid

- 20 °C to + 80 °C

2.2.4 Range of thermometer scale

FSA / FSK

Thermometer T for FSA :

+ 20 °C to + 80 °C

Thermometer FT for FSA / FSK :

0 °C to + 100 °C

2.3. ELECTRICAL CHARACTERISTICS FSK

2.3.1 Electrical functions

Type O / normally closed

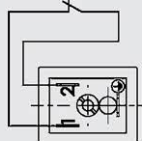

Type O / normally closed (plug Z4 and type B)

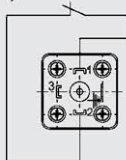

Type O / normally closed (plug - SEW)

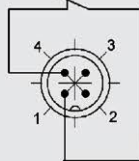

Type C / normally open

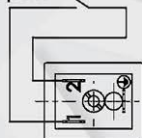

Type W / change over (connector Z4 and type B)

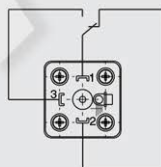

Type W / change over (plug - SEW)

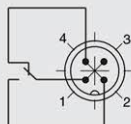

FSK-2SP

Type W / change over

As delivered, switching point at bottom activated by magnetic field.

Size 127, 254, 381



| Contact assignment | bottom | top |
|--------------------|--------|-------|
| Float setting | | |
| Minimum | 5 - 4 | 5 - 3 |
| Maximum | 5 - 1 | 5 - 2 |

Size 176

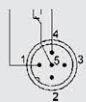

| Contact assignment | top |
|--------------------|-------|
| Float setting | |
| Maximum | 5 - 4 |

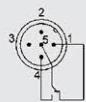

| Contact assignment | bottom |
|--------------------|--------|
| Float setting | |
| Minimum | 5 - 4 |

FSK-V

Type W / change over

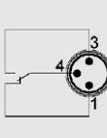

| Contact assignment | bottom | top |
|--------------------|--------|-------|
| Float setting | | |
| Minimum | 3 - 4 | 1 - 4 |
| Maximum | 1 - 4 | 3 - 4 |

2.3.2 Contact load

max. 8 W

2.3.3 Switching voltage

1-48 V AC/DC

2.3.4 Switching current

max. 0.2 A

2.3.5 Protection class

IP 65

2.3.6 Viscosity range

max. 2000 mm²/s

2.4. ELECTRICAL CHARACTERISTICS TS / TS-L

2.4.1 Electrical function

N/C contact

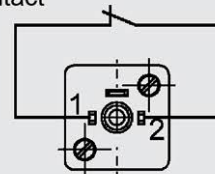

2.4.2 Switching power

2.5 A/50 V - 10,000 switching operations

0.5 A/50 V - 100,000 switching operations

2.4.3 Minimum switching current

50 mA

2.4.4 Switching tolerance

± 5 K

2.4.5 Switching hysteresis

Normally closed

60 °C - 10-15 K

70 °C - 10-15 K

80 °C - 10-20 K

3. DIMENSIONS

3.1. FLUID LEVEL GAUGE FSA FSA standard

FSA-IB (with non-return valve)

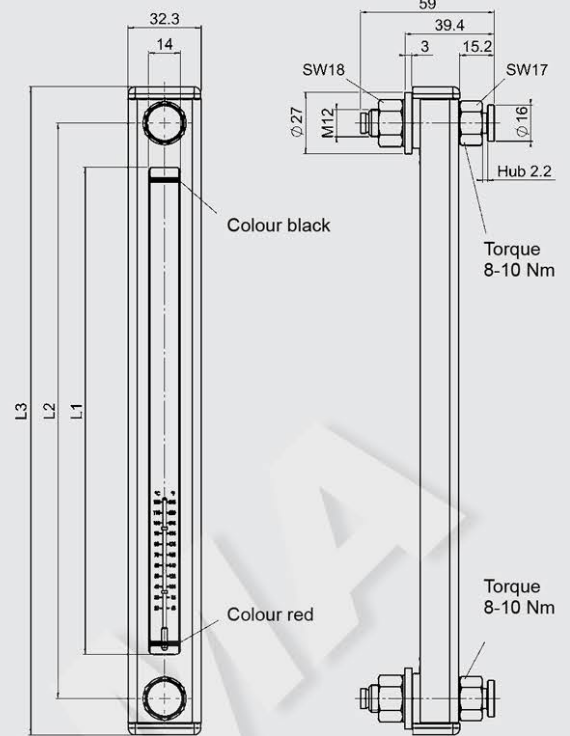
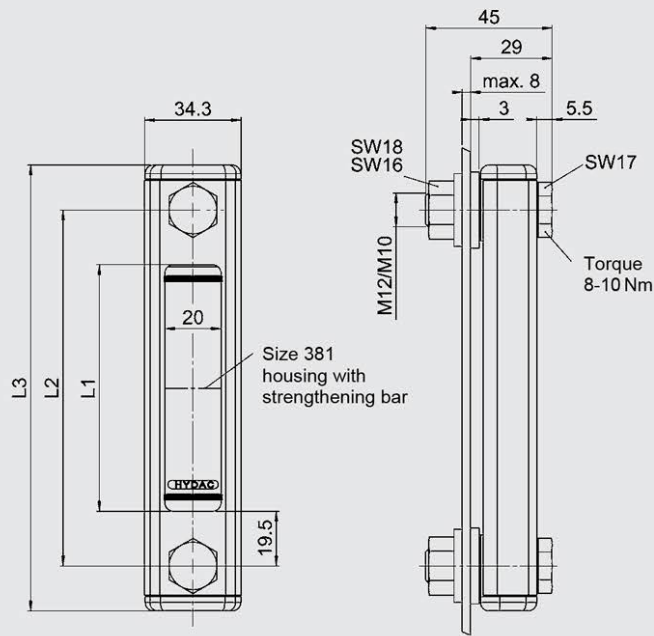

FSA with temperature switch TS

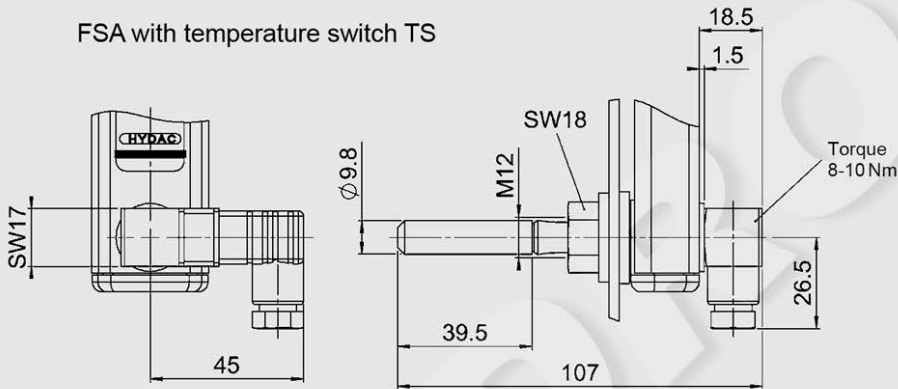

FSA with temperature gauge

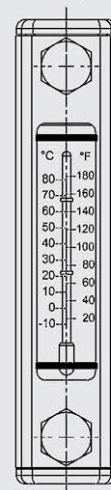

FSA / FSK with temperature gauge

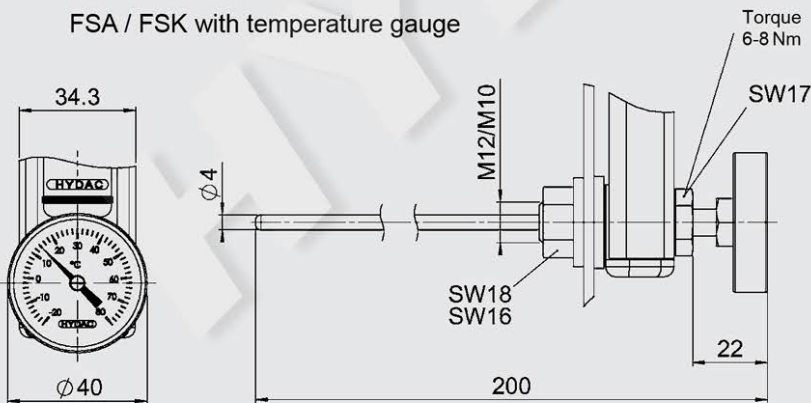

| Size = centre distance of bolts | L3 | L1 | L2 |
|------------------------------------|-----|-----|-----|
| 76 | 108 | 37 | 76 |
| 127 | 159 | 88 | 127 |
| 176 | 208 | 137 | 176 |
| 254 | 286 | 215 | 254 |
| 381 | 413 | 342 | 381 |

3.2. FLUID LEVEL SENSOR FSK

FSK standard

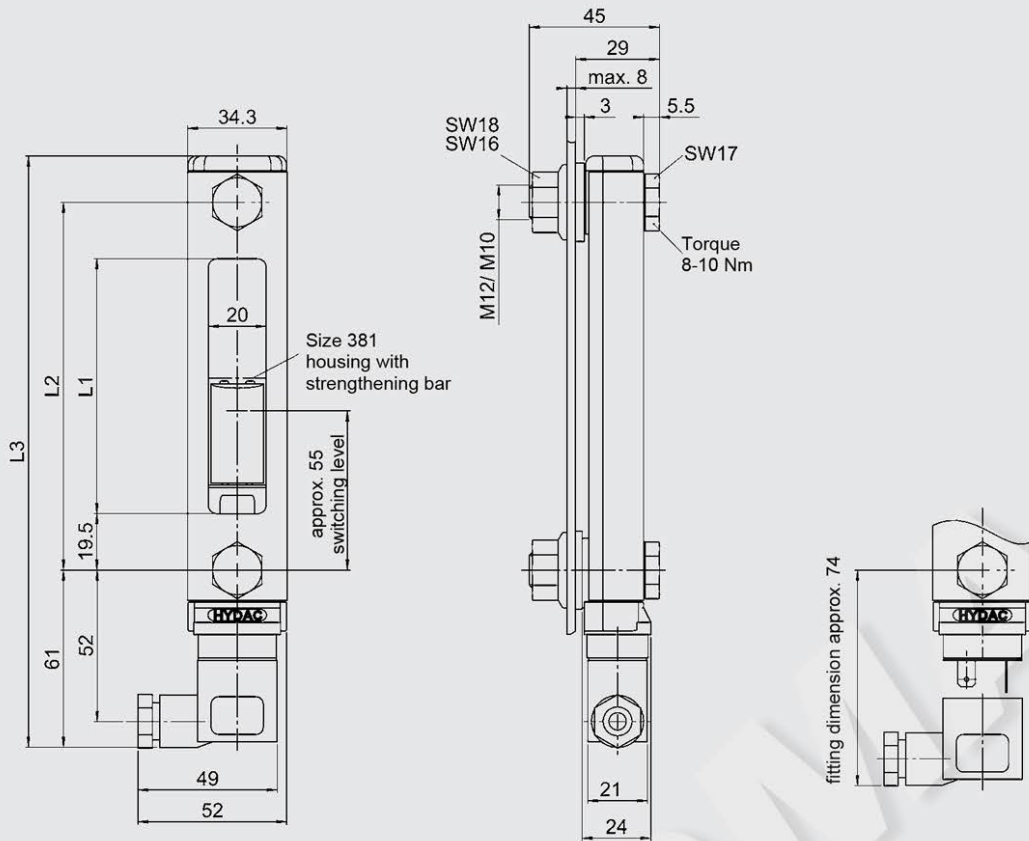

FSK Hirschmann plug Z4

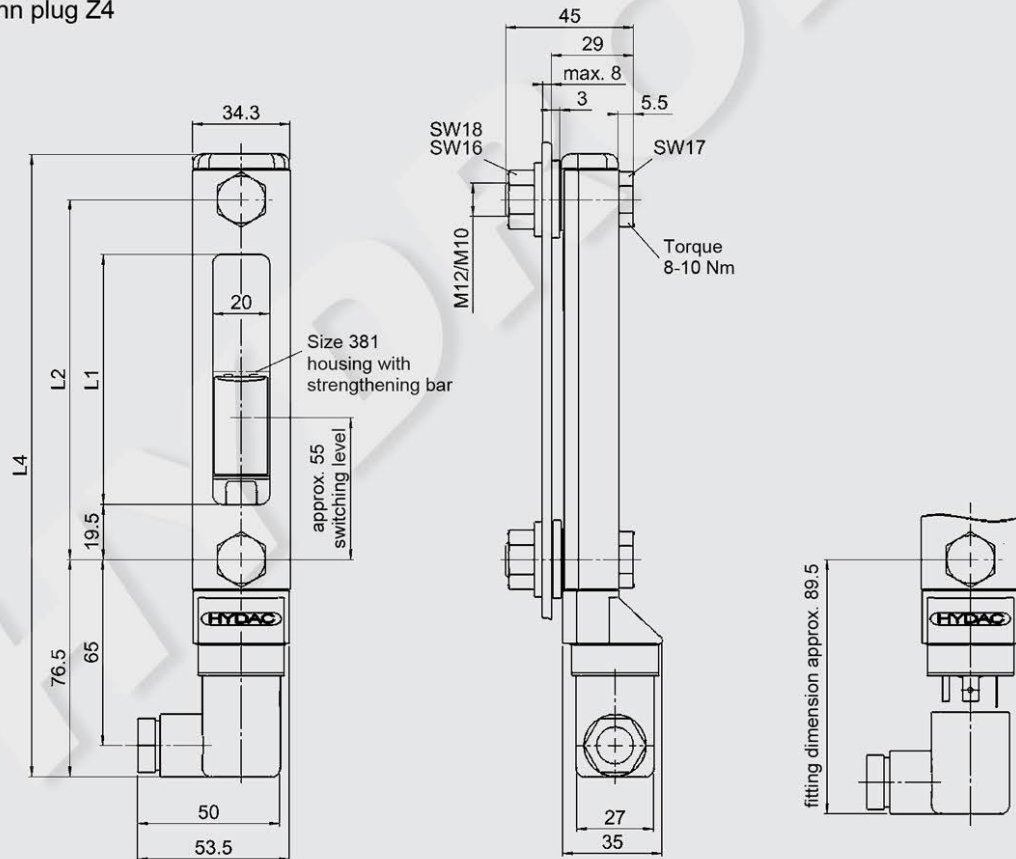

| Size = centre distance of bolts | L1 | L2 | L3 | L4 |
|------------------------------------|-----|-----|-----|-------|
| 127 | 88 | 127 | 204 | 219.5 |
| 176 | 137 | 176 | 253 | 268.5 |
| 254 | 215 | 254 | 331 | 346.5 |
| 381 | 342 | 381 | 458 | 473.5 |

FSK sensor connection SEW-M12x1 horizontal

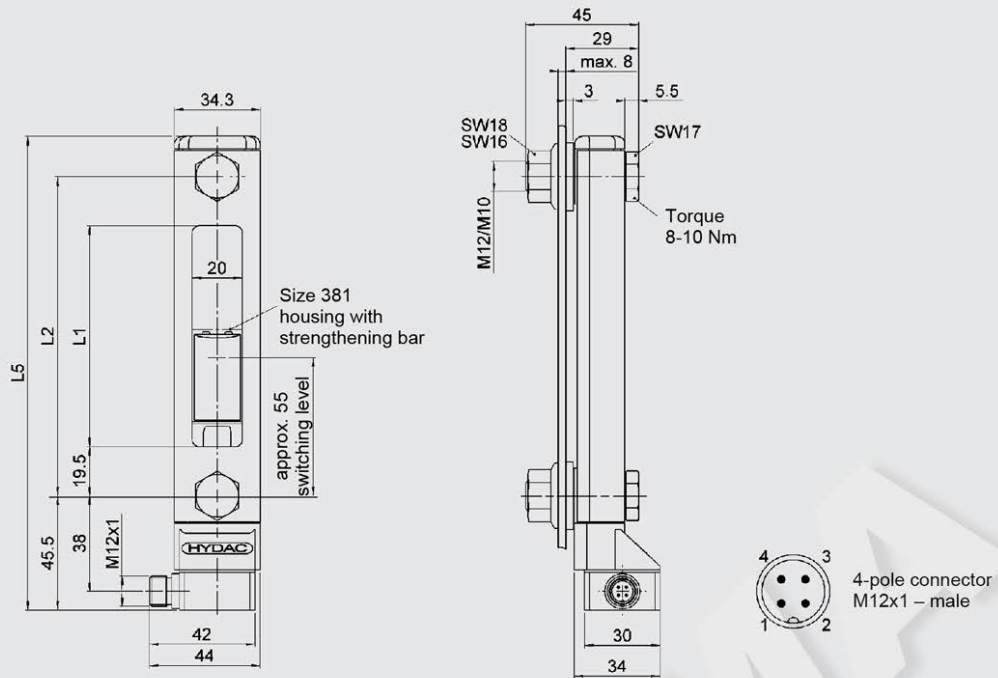

FSK sensor connection SES-M12x1 vertical

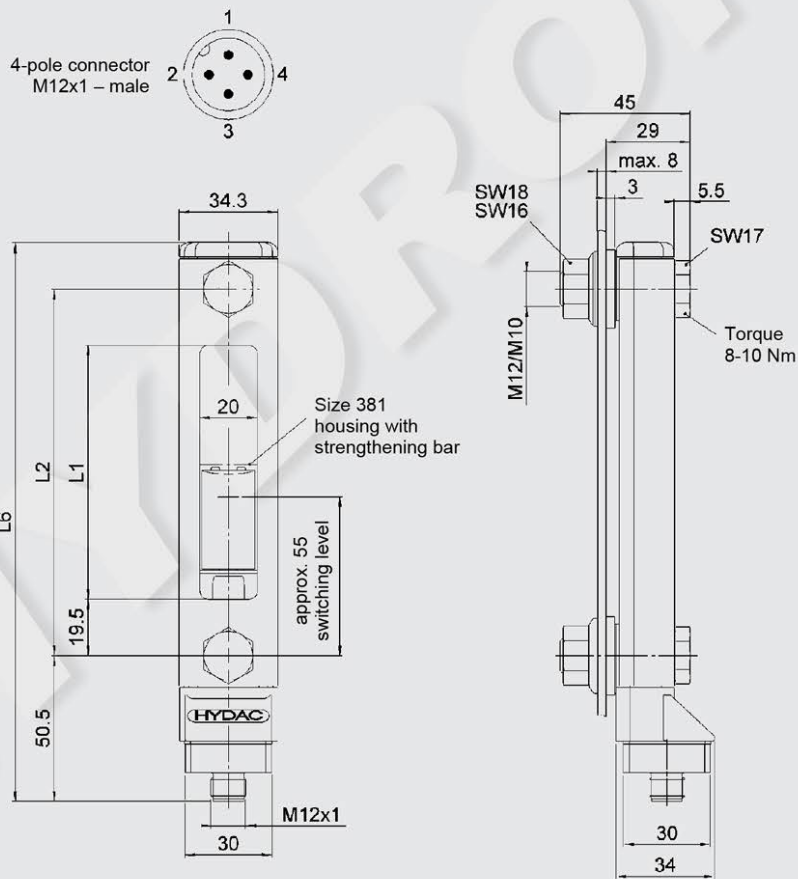

| Size = centre distance of bolts | L1 | L2 | L5 | L6 |
|------------------------------------|-----|-----|-------|-------|
| 127 | 88 | 127 | 188.5 | 193.5 |
| 176 | 137 | 176 | 237.5 | 242.5 |
| 254 | 215 | 254 | 315.5 | 320.5 |
| 381 | 342 | 381 | 442.5 | 447.5 |

FSK male connection Form B

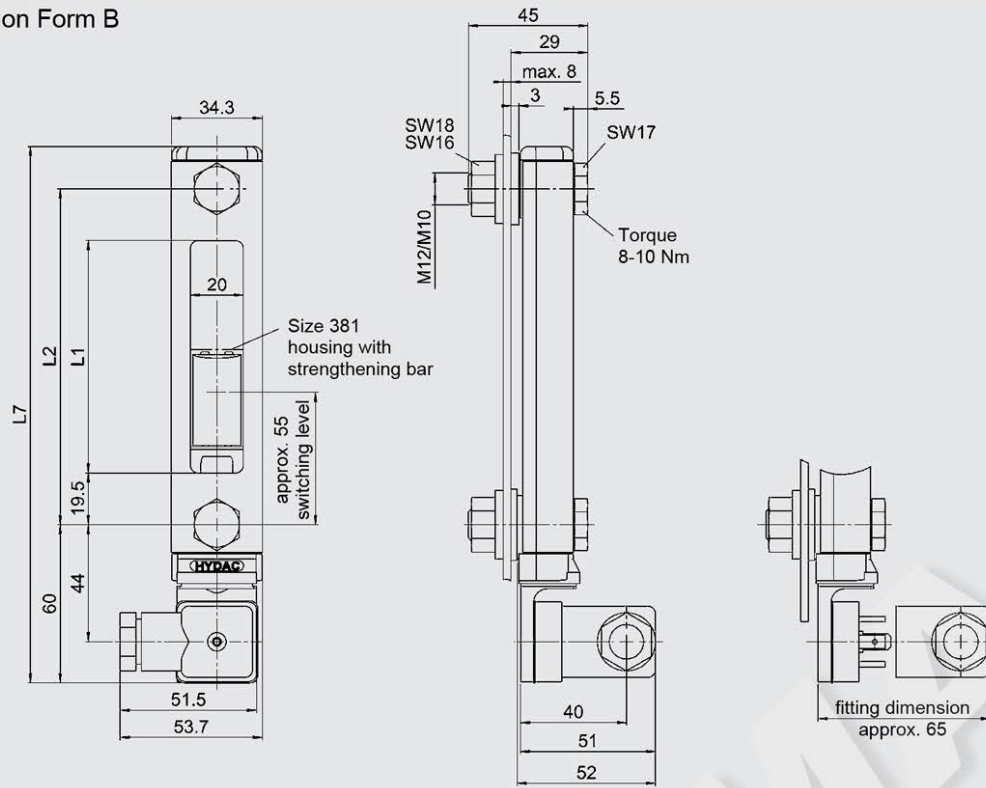

| Size = centre distance of bolts | L1 | L2 | L7 |
|---------------------------------|-----|-----|-----|
| 127 | 88 | 127 | 203 |
| 176 | 137 | 176 | 252 |
| 254 | 215 | 254 | 330 |
| 381 | 342 | 381 | 457 |

FSK with two switching points

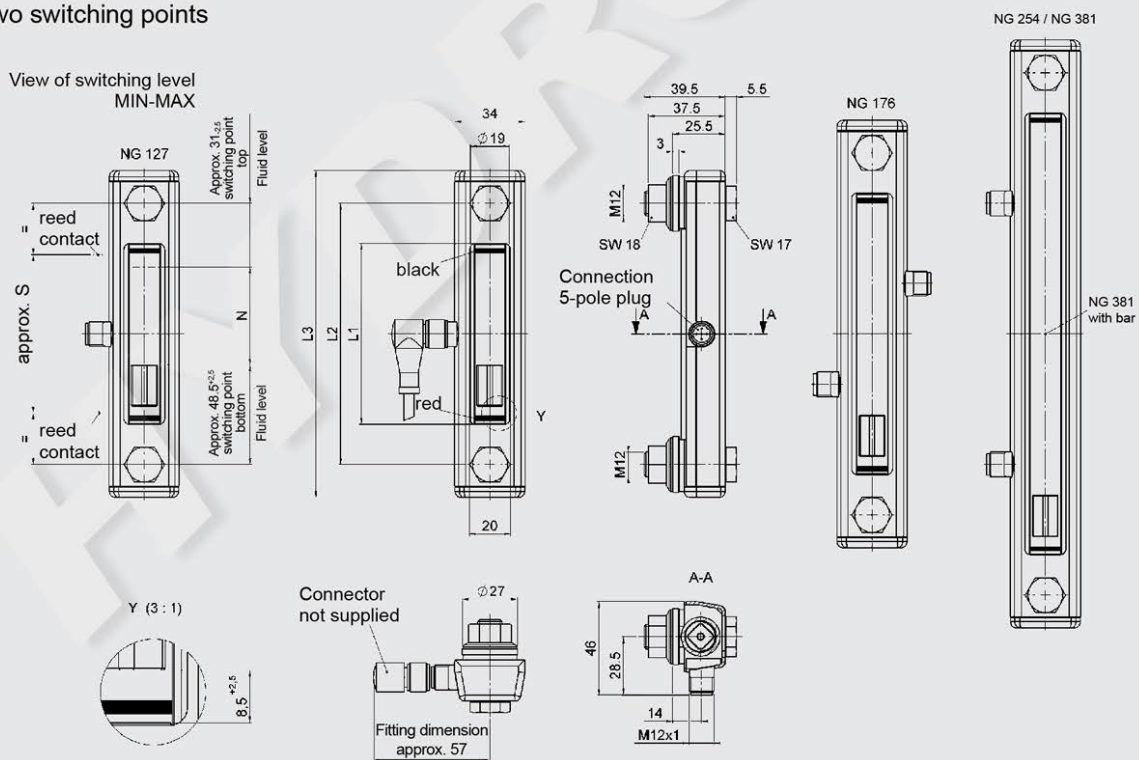

| Type | Nom. size | L1 | L2 | L3 | N | approx. S |
|------------------------|-----------|-----|-----|-----|-------|-----------|
| FSK-127-1.0/WI-/12/2SP | 127 | 88 | 127 | 159 | 47.5 | 77 |
| FSK-176-1.0/WI-/12/2SP | 176 | 137 | 176 | 208 | 96.5 | 126 |
| FSK-254-1.0/WI-/12/2SP | 254 | 215 | 254 | 286 | 174.5 | 204 |
| FSK-381-1.0/WI-/12/2SP | 381 | 342 | 381 | 413 | 301.5 | 331 |

FSK with variable switching points

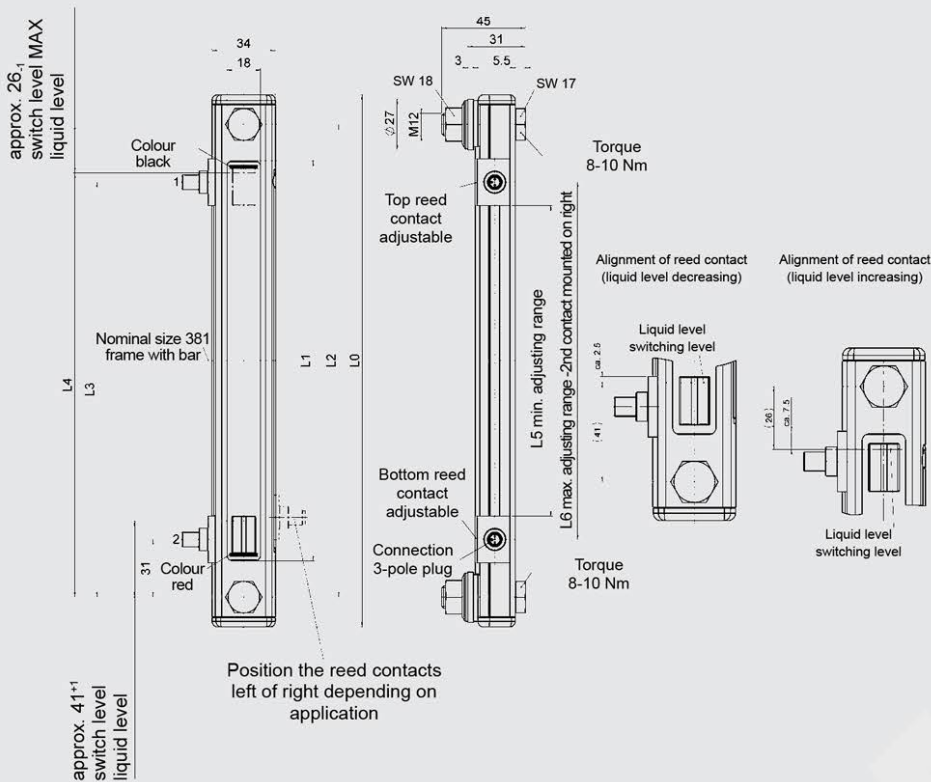

| Type | Nom. size | L0 | L1 | L2 | L3 | L4 | L5 | L6 |
|----------|-----------|-----|-----|-----|-----|-----|-----|-----|
| FSKV-127 | 127 | 159 | 88 | 127 | 96 | 101 | 40 | 65 |
| FSKV-176 | 176 | 208 | 137 | 176 | 145 | 150 | 89 | 114 |
| FSKV-254 | 254 | 286 | 215 | 254 | 223 | 228 | 167 | 192 |
| FSKV-381 | 381 | 413 | 342 | 381 | 350 | 355 | 294 | 319 |

Angled connector M8x1 for FSKV

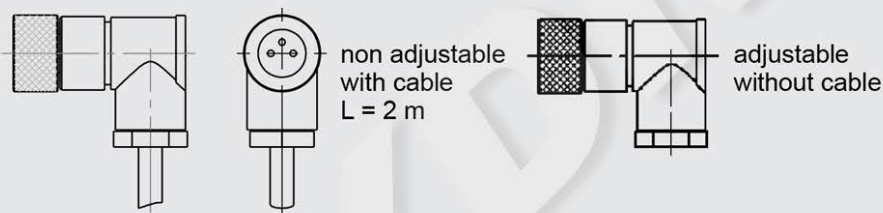

Order no.: 6105865

6105866

FSK with temperature switch TS-L

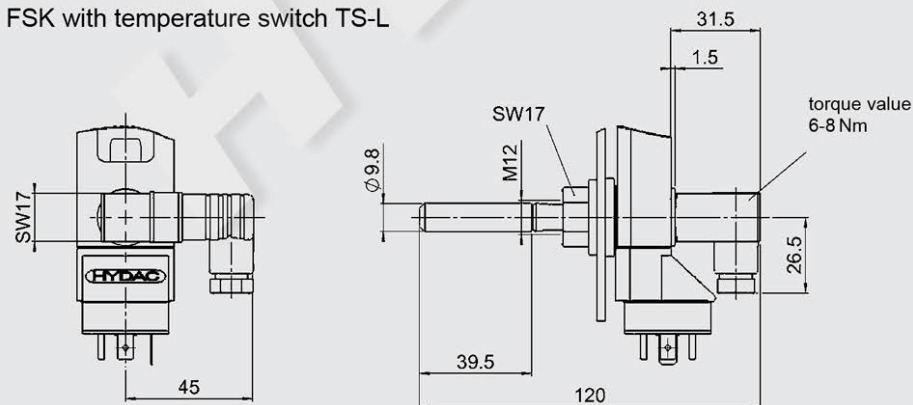

3.3. TEMPERATURE SWITCH TS / TS-L

See FSA with TS fitted
See FSK with TS-L fitted

www.hydroma.cz

www.hydroma.eu

4. SPARE PARTS

4.1. SEAL KIT

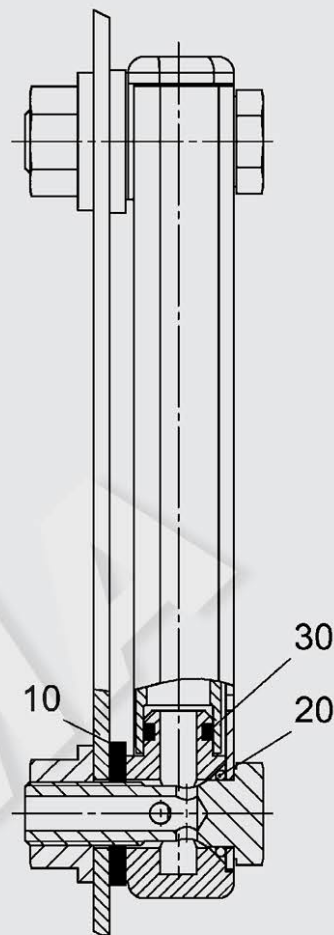

Seal kit

Order
no.= Part
number

FSA - 76 - 381 - 1.X / - /12 NBR 704 616

FSA - 76 - 381 - 2.X / - /12 FKM 704 627

FSA - 76 - 381 - 1.X / - /10 NBR 3248767

FSA - 76 - 381 - 2.X / - /10 FKM 3395614

5. NOTE

The information in this brochure relates to the operating conditions and applications described.

For applications and operating conditions not described, please contact the relevant technical department.

Subject to technical modifications.

HYDAC Accessories GmbH

Hirschbachstr. 2

66280 Sulzbach/Saar

Tel.: +49 (0)6897 - 509-01

Fax: +49 (0)6897 - 509-1009

Internet: www.hydac.com

E-Mail: info@hydac.com

www.hidromasystems.pl