

Part number:

HYDROMA

HYDRAULICKÉ SYSTÉMY

**HIDROMA
SYSTEMS**

UKŁADY HYDRAULICZNE

HYDROMA

ГИДРАВЛИЧЕСКИЕ СИСТЕМЫ

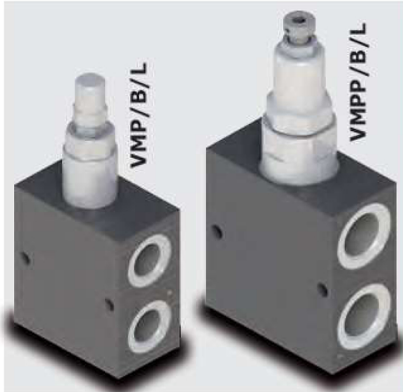

Type VMP/B/L - VMPP/B/L pressure relief valves

- Direct acting
- Piloted operated

Technical specifications and diagrams are measured with mineral oil of 46 cSt viscosity at 40°C (104°F) temperature.

	VMP/B/L					VMPP/B/L			
	02-14	03-14	5-38 5-12	5Y-38	10-12 10-34	20-34 20-100	10-12	20-34 20-100	45-114
Nominal flow	5 l/min (1.3 US gpm)	10 l/min (2.6 US gpm)	35 l/min (9.2 US gpm)	35 l/min (9.2 US gpm)	60 l/min (16 US gpm)	100 l/min (26.4 US gpm)	70 l/min (18.5 US gpm)	120 l/min (31.7 US gpm)	250 l/min (66 US gpm)
Max. pressure	Aluminium body = 210 bar (3050 psi) Steel body = 350 bar (5100 psi)								
Oil leakage at 80% of max. setting	5 cm ³ /min (0.30 in ³ /min)	5 cm ³ /min (0.30 in ³ /min)	3 cm ³ /min (0.18 in ³ /min)	1 cm ³ /min (0.06 in ³ /min)	3 cm ³ /min (0.18 in ³ /min)	3 cm ³ /min (0.18 in ³ /min)	20 cm ³ /min (1.22 in ³ /min)	25 cm ³ /min (1.52 in ³ /min)	40 cm ³ /min (2.44 in ³ /min)
Fluid	mineral based oil								
Viscosity	from 10 to 200 cSt								
Max. level of contamination	18/16/13 ISO4406								
Fluid temp.	with NBR seals from -20°C (-4°F) to 80°C (176°F)								
Environmental temp. for working conditions	from -40°C (-40°F) to 100°C (212°F)								
Weight	alum.	0.21 kg (0.46 lb)	0.40 kg (0.88 lb)	38: 0.48 kg (1.06 lb) 12: 0.46 kg (1.01 lb)	0.47 kg (1.04 lb)	12: 0.66 kg (1.46 lb) 34: 0.76 kg (1.68 lb) 100: 1.77 kg (3.90 lb)	34: 1.18 kg (2.60 lb) 100: 1.77 kg (3.90 lb)	0.66 kg (1.46 lb) 34: 1.27 kg (2.80 lb) 100: 1.85 kg (4.08 lb)	2.73 kg (6.02 lb)
	steel	0.99 kg (2.18 lb)	0.85 kg (1.87 lb)	38: 1.08 kg (2.38 lb) 12: 0.99 kg (2.18 lb)		12: 1.40 kg (3.09 lb) 34: 1.67 kg (3.68 lb) 100: 4.08 kg (8.99 lb)	34: 2.52 kg (5.56 lb) 100: 4.08 kg (8.99 lb)	1.39 kg (3.06 lb) 34: 2.60 kg (5.73 lb) 100: 4.16 kg (9.17 lb)	6.12 kg (13.49 lb)

NOTE - For different conditions, please contact Walvoil Sales Dpt.

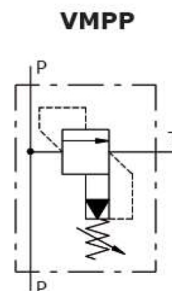
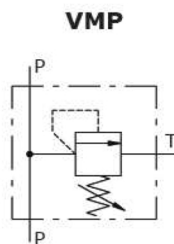

Dimensions

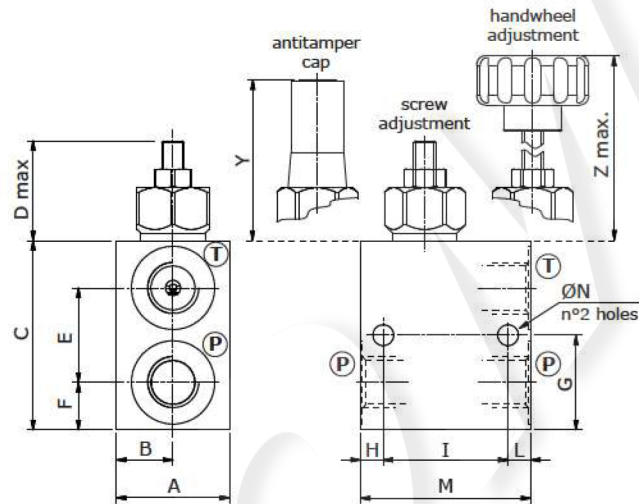

Valve type	All ports
VMP/B/L 02-14	G1/4
VMP/B/L 03-14	G1/4
Valve type	All ports
VMP/B/L 02-14/SAE	SAE6
VMP/B/L 03-14/SAE	SAE6

Dimensions are in mm-in

Valve type	A	B	C	D max	E	F	G	H-L	I	M	ØN	Y	ØK	Z max
VMP/B/L 02-14	30-1.18	15-0.59	50-1.97	29-1.14	25-0.98	12.5-0.49	25-0.98	6-0.24	33-1.30	45-1.77	5.5-0.22	42.5-1.67	30-1.18	49-1.93
VMP/B/L 02-14/SAE														
VMP/B/L 03-14	30-1.18	15-0.59	60-2.36	53-2.09	32-1.26	14-0.55	30-1.18	6-0.24	48-1.89	60-2.98	6.5-0.25	52-2.05	40-1.57	86.5-3.41
VMP/B/L 03-14/SAE														

Valve type	All ports
VMP/B/L 5-38	G3/8
VMP/B/L 5-12	G1/2
VMP/B/L 5Y-38	G3/8
VMP/B/L 5Y-12	G1/2
Valve type	All ports
VMP/B/L 5-38/SAE	SAE8
VMP/B/L 5-12/SAE	SAE10
VMP/B/L 5Y-38/SAE	SAE8
VMP/B/L 5Y-12/SAE	SAE10

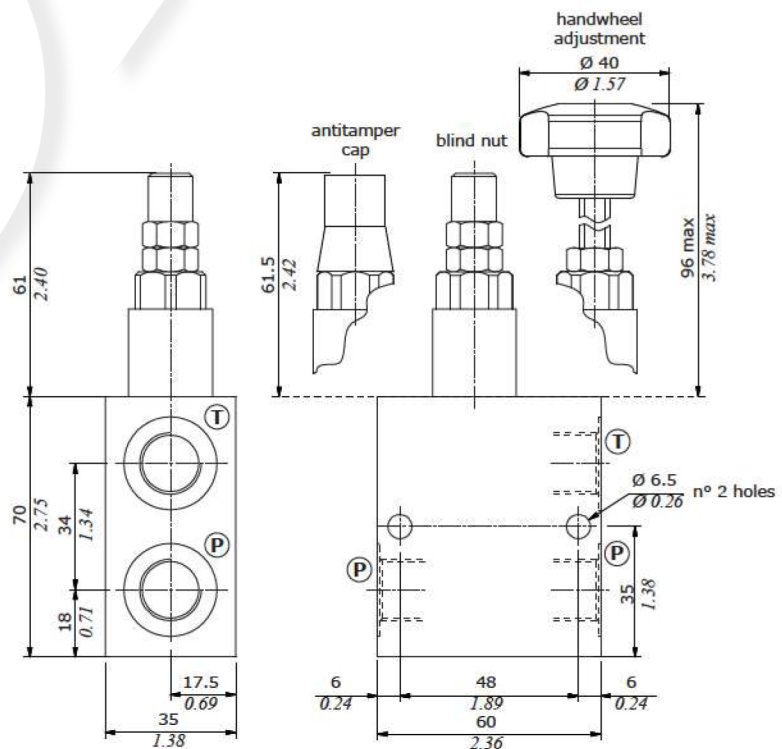

Ordering codes

Valve type	All ports	Valve type	All ports
VMP/B/L 10-12	G1/2	VMP/B/L 10-12/SAE	SAE10
VMP/B/L 10-34	G3/4	VMP/B/L 10-34/SAE	SAE12
VMP/B/L 20-34	G3/4	VMP/B/L 20-34/SAE	SAE12
VMP/B/L 20-100	G1"	VMP/B/L 20-100/SAE	SAE16

Dimensions are in mm-in

Valve type	A	B	C	D	E	E
VMP/B/L 10-12	35-1.38	17.5-0.69	78-3.07	67-2.64	40-2.28	40-2.28
VMP/B/L 10-12/SAE						
VMP/B/L 10-34	40-1.57	20-0.79	90-3.54	67-2.64	50-1.97	50-1.97
VMP/B/L 10-34/SAE						
VMP/B/L 20-34	50-1.97	25-0.98	100-3.94	76.5-3.01	57-2.24	57-2.24
VMP/B/L 20-34/SAE						
VMP/B/L 20-100	60-3.34	30-1.18	120-4.72	76.5-3.01	65-2.56	65-2.56
VMP/B/L 20-100/SAE						

F	G	H	I	L	ØN	ØK	Y	Z max
20-0.79	39-1.53	6-0.24	70-2.75	58-2.28	6.5-0.25	40-1.57	64.7-2.55	98-3.59
20-0.79	45-1.77	8-0.31	70-2.75	54-2.12	8.5-0.33	40-1.57	64.7-2.55	98-3.59
22-0.87	50-1.97	8-0.31	70-2.75	54-2.12	8.5-0.33	40-1.57	74-2.91	89.5-3.52
30-1.18	63-2.48	10-0.39	85-3.34	65-2.56	8.5-0.33	40-1.57	74-2.91	89.5-3.52

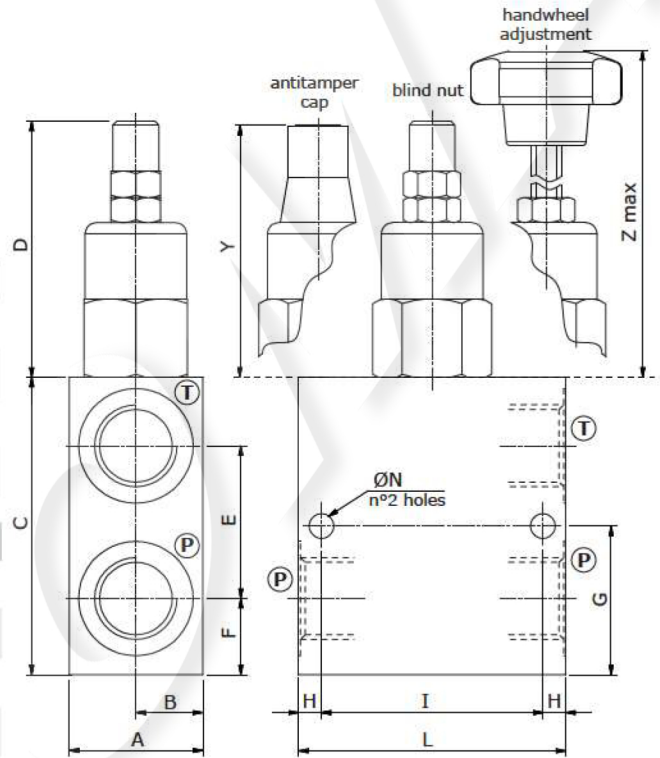

Valve type	All ports	Valve type	All ports
VMPP/B/L 10-12	G1/2	VMPP/B/L 10-12/SAE	SAE10
VMPP/B/L 20-34	G3/4	VMPP/B/L 20-34/SAE	SAE12
VMPP/B/L 20-100	G1"	VMPP/B/L 20-100/SAE	SAE16
VMPP/B/L 45-114	G1"1/4	VMPP/B/L 45-114/SAE	SAE20

Dimensions are in mm-in

Valve type	A	B	C	D max	E	F
VMPP/B/L 10-12	35-1.38	78-3.07	17.5-0.69	74.3-2.96	39-1.53	6-0.24
VMPP/B/L 10-12/SAE						
VMPP/B/L 20-34	50-1.97	100-3.94	25-0.98	77.5-3.05	50-1.97	8-0.31
VMPP/B/L 20-34/SAE						
VMPP/B/L 20-100	60-2.36	120-4.72	30-1.18	77.5-3.05	63-2.48	10-0.39
VMPP/B/L 20-100/SAE						
VMPP/B/L 45-114	70-2.75	135-5.31	35-1.38	94.5-3.72	70-2.75	10-0.39
VMPP/B/L 45-114/SAE						

G	H	I	L	ØN	Y	ØK	Z max
70-2.75	58-2.28	20-0.79	40-1.57	6.5-0.25	25.5-1	40-1.57	56-2.2
70-2.75	54-2.12	22-0.87	57-2.44	8.5-0.33	25.5-1	40-1.57	56-2.2
85-3.34	65-2.56	30-1.18	65-2.56	8.5-0.33	25.5-1	40-1.57	56-2.2
100-3.94	80-3.15	35-1.38	68-2.68	10.5-0.41	28-1.10	40-1.57	56-2.20

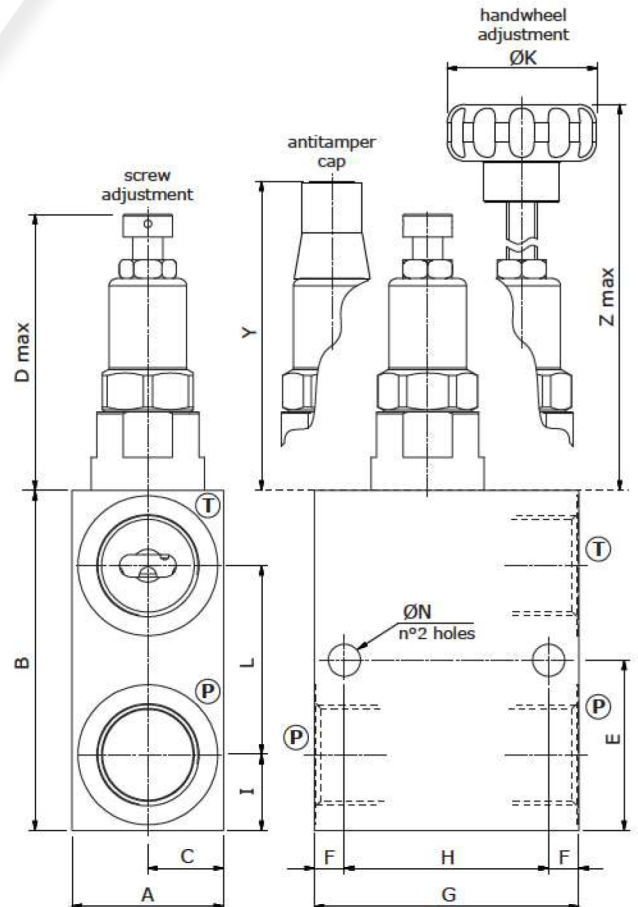

Ordering codes and description composition

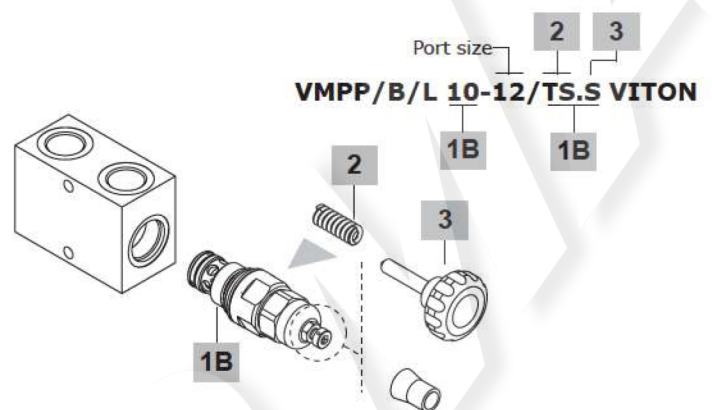
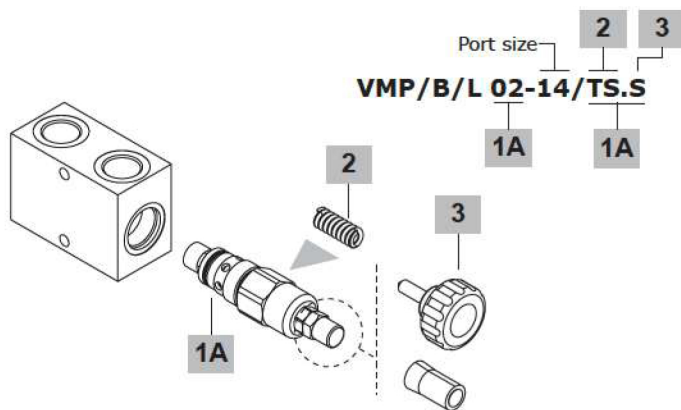

VMP/B/L complete direct acting valves

TYPE	CODE	DESCRIPTION
Configuration with G1/4 standard thread		
<i>Standard setting 150 bar @ 3 l/min (2175 psi @ 0.79 US gpm)</i>		
VMP/B/L 02-14/TS.G	1111001104	Aluminium body, range 50-220 bar (725-3200 psi)
VMP/B/L 02-14/TS.G/ac	1111002103	Steel body, as previous one
VMP/B/L 03-14/TS.S	1111011104	Aluminium body, range 50-200 bar (725-3200 psi)
VMP/B/L 03-14/TS.S/ac	1111012101	Steel body, as previous one
Configuration with G3/8 standard thread		
<i>Standard setting 160 bar @ 5 l/min (2320 psi @ 1.32 US gpm)</i>		
VMP/B/L 5-38/TS.S	1111021104	Aluminium body, range 50-220 bar (725-3200 psi)
VMP/B/L 5-38/TS.S/ac	1111022101	Steel body, as previous one
VMP/B/L 5Y-38/TS.S	1111021116	Aluminium body, range 50-220 bar (725-3200 psi)
Configuration with G1/2 standard thread		
<i>Standard setting 160 bar @ 5 l/min (2320 psi @ 1.32 US gpm)</i>		
VMP/B/L 5-12/TS.S	1111021154	Aluminium body, range 50-220 bar (725-3200 psi)
VMP/B/L 5-12/TS.S/ac	1111022150	Steel body, as previous one
VMP/B/L 10-12/TS.S	1111031104	Aluminium body, range 50-220 bar (725-3200 psi)
VMP/B/L 10-12/TS.S/ac	1111032100	Steel body, as previous one
Configuration with G3/4 standard thread		
<i>Standard setting 160 bar @ 5 l/min (2320 psi @ 1.32 US gpm)</i>		
VMP/B/L 10-34/TS.S	1111031154	Aluminium body, range 50-220 bar (725-3200 psi)
VMP/B/L 10-34/TS.S/ac	1111032151	Steel body, as previous one
VMP/B/L 20-34/TS.S	1111041104	Aluminium body, range 50-220 bar (725-3200 psi)
VMP/B/L 20-34/TS.S/ac	1111042102	Steel body, as previous one
Configuration with G1" standard thread		
<i>Standard setting 160 bar at 5 l/min (2320 psi at 1.32 US gpm)</i>		
VMP/B/L 20-100/TS.S	1111041154	Aluminium body, range 50-220 bar (725-3200 psi)
VMP/B/L 20-100/TS.S/ac	1111042150	Steel body, as previous one
Configuration with SAE6 standard thread		
<i>Standard setting 150 bar @ 3 l/min (2175 psi @ 0.79 US gpm)</i>		
VMP/B/L 02-14/TS.G/SAE	1111001201	Aluminium body, range 50-220 bar (725-3200 psi)
VMP/B/L 03-14/TS.S/SAE	1111011200	Aluminium body, range 50-200 bar (725-3200 psi)
Configuration with SAE8 standard thread		
<i>Standard setting 160 bar @ 5 l/min (2320 psi @ 1.32 US gpm)</i>		
VMP/B/L 5-38/TS.S/SAE	1111021200	Aluminium body, range 50-220 bar (725-3200 psi)
Configuration with SAE10 standard thread		
<i>Standard setting 160 bar @ 5 l/min (2320 psi @ 1.32 US gpm)</i>		
VMP/B/L 5-12/TS.S/SAE	1111021250	Aluminium body, range 50-220 bar (725-3200 psi)
VMP/B/L 10-12/TS.S/SAE	1111031200	Aluminium body, range 50-220 bar (725-3200 psi)

VMP/B/L complete direct acting valves (cont.)

Configuration with SAE12 standard thread		
<i>Standard setting 160 bar @ 5 l/min (2320 psi @ 1.32 US gpm)</i>		
VMP/B/L 10-34/TS.S/SAE	1111031250	Aluminium body, range 50-220 bar (725-3200 psi)
VMP/B/L 20-34/TS.S/SAE	1111041200	Aluminium body, range 50-220 bar (725-3200 psi)
Configuration with SAE16 standard thread		
<i>Standard setting 160 bar at 5 l/min (2320 psi at 1.32 US gpm)</i>		
VMP/B/L 20-100/TS.S/SAE	1111041250	Aluminium body, range 50-220 bar (725-3200 psi)

VMPP/B/L complete pilot operated valves

Configuration with G1/2 standard thread		
<i>Standard setting 120 bar at 10 l/min (1740 psi at 2.64 US gpm)</i>		
TYPE: VMPP/B/L 10-12/TS.W VITON	CODE: 1132031100	DESCRIPTION: Aluminium body, range 20-400 bar (290-5800 psi)
TYPE: VMPP/B/L 10-12/TS.W/ac VITON	CODE: 1132032100	DESCRIPTION: Steel body, as previous one
Configuration with G3/4 standard thread		
<i>Standard setting 120 bar at 10 l/min (1740 psi at 2.64 US gpm)</i>		
TYPE: VMPP/B/L 20-34/TS.W VITON	CODE: 1132041100	DESCRIPTION: Aluminium body, range 20-400 bar (290-5800 psi)
TYPE: VMPP/B/L 20-34/TS.W/ac VITON	CODE: 1132042100	DESCRIPTION: Steel body, as previous one
Configuration with G1" standard thread		
<i>Standard setting 120 bar at 10 l/min (1740 psi at 2.64 US gpm)</i>		
TYPE: VMPP/B/L 20-100/TS.W VITON	CODE: 1132041150	DESCRIPTION: Aluminium body, range 20-400 bar (290-5800 psi)
TYPE: VMPP/B/L 20-100/TS.W/ac VITON	CODE: 1132042151	DESCRIPTION: Steel body, as previous one
Configuration with G1" 1/4 standard thread		
<i>Standard setting 160 bar at 5 l/min (2320 psi at 1.32 US gpm)</i>		
TYPE: VMPP/B/L 45-114/TS.S	CODE: 1132061104	DESCRIPTION: Aluminium body, range 50-220 bar (725-3200 psi)
TYPE: VMPP/B/L 45-114/TS.S/ac	CODE: 1132062101	DESCRIPTION: Steel body, as previous one
Configuration with SAE10 standard thread		
<i>Standard setting 120 bar at 10 l/min (1740 psi at 2.64 US gpm)</i>		
TYPE: VMPP/B/L 10-12/TS.W SAE VITON	CODE: 1132031200	DESCRIPTION: Aluminium body, range 20-400 bar (290-5800 psi)
Configuration with SAE12 standard thread		
<i>Standard setting 120 bar at 10 l/min (1740 psi at 2.64 US gpm)</i>		
TYPE: VMPP/B/L 20-34/TS.W VITON SAE	CODE: 1132041200	DESCRIPTION: Aluminium body, range 20-400 bar (290-5800 psi)
Configuration with SAE20 standard thread		
<i>Standard setting 160 bar at 5 l/min (2320 psi at 1.32 US gpm)</i>		
TYPE: VMPP/B/L 45-114/TS.S/SAE	CODE: 1132061200	DESCRIPTION: Aluminium body, range 50-220 bar (725-3200 psi)

For other steel body configurations, SAE thread and configurations with FPM (Viton) seals, please contact our Sales Dept.

Ordering codes and description composition

1A Direct acting pressure relief valves

TYPE	CODE	DESCRIPTION
For G1/4 ports configuration		
VMP 02/TS.G	1100000101	Range 50-220 bar (725-3200 psi)
For VMP/B/L 03-14 valve		
MC08A/0S2B	OMC08002000	Range 50-200 bar (725-2900 psi)
MC08R/0Y2B	OMC08002051	Range 40-200 bar (580-2900 psi)
For G3/8 and G1/2 ports configuration		
VMP 5/TS.S	1100520400	Range 50-220 bar (725-3200 psi)
VMP 5Y/TS.S	1100520406	Range 140-190 bar (2030-2755 psi)
VMP 5J/TS.S	1100520432	Range 63-200 bar (913-2900 psi)
For G1/2 and G3/4 ports configuration		
VMP 10/TS.S	1100530400	Range 50-220 bar (725-3200 psi)
VMP 10Y/TS.S	1100530407	Range 125-250 bar (1810-3600 psi)
For G3/4 and G1" ports configuration		
VMP 20/TS.S	1100540400	Range 50-220 bar (725-3200 psi)
VMP 20Y/TS.S	1100540407	Range 125-250 bar (1810-3600 psi)

1B Pilot operated pressure relief valves

TYPE	CODE	DESCRIPTION
For G1/2 ports configuration		
VMPX 10/1(XG)	XCAR110313	Range 20-400 bar (290-5800 psi)
For G3/4 and G1" ports configuration		
VMPX 20/1(XG)	X007211120	Range 20-400 bar (290-5800 psi)
For G1"1/4 ports configuration		
VMPP 45/TS.S	1130060404	Range 50-250 bar (725-3600 psi)

2 Pressure setting spring

TYPE	CODE	DESCRIPTION
For VMP 02 valve		
TV	3ML1081400	Range 5-80 bar (72.5-1160 psi)
TS	3ML1081401	Range 50-220 bar (725-3200 psi)
TR	3ML1081402	Range 180-350 bar (2600-5100 psi)
For MC08 valve		
TB	3ML1092500	Range 5-50 bar (72.5-725 psi)
TS	3ML1092501	Range 50-200 bar (725-2900 psi)
TR	3ML1092502	Range 180-350 bar (2600-5100 psi)
For VMP 5, VMP 5J and VMPP 45 valves		
TB	3MOL314311	Range 5-40 bar (72.5-580 psi)
TV	3MOL314330	Range 20-80 bar (290-1160 psi)
TS	3MOL315330	Range 50-220 bar (725-3200 psi)
TR	3ML1143600	Range 180-350 bar (2600-5100 psi)

2 Pressure setting spring (continue)

For VMP 5Y valve		
TB	3MOL314311	Range 5-80 bar (72.5-1160 psi)
TV	3MOL314330	Range 40-150 bar (580-2200 psi)
TS	3ML1143400	Range 140-190 bar (2600-5100 psi)
TR	3MOL315330	Range 180-350 bar (2600-5100 psi)
For VMP 10 valve		
TB	3MOL316410	Range 5-40 bar (72.5-580 psi)
TV	3ML1154300	Range 20-80 bar (290-1160 psi)
TS	3MOL317420	Range 50-220 bar (725-3200 psi)
TR	3MOL317440	Range 180-350 bar (2600-5100 psi)
For VMP 10Y valve		
TV	3MOL316580	Range 100-160 bar (1450-3220 psi)
TS	3MOL317560	Range 125-250 bar (1800-3600 psi)
TR	3MOL317570	Range 200-315 bar (2900-4600 psi)
For VMP 20 valve		
TB	3ML1184300	Range 5-40 bar (72.5-580 psi)
TV	3ML1174500	Range 20-80 bar (290-1160 psi)
TS	3ML1204200	Range 50-220 bar (725-3200 psi)
TR	3ML1214500	Range 180-350 bar (2600-5100 psi)
For VMP 20Y valve		
TV	3MOL318690	Range 100-160 bar (1450-3220 psi)
TS	3MOL321621	Range 125-250 bar (1800-3600 psi)
TR	3MOL321620	Range 200-315 bar (2900-4600 psi)

3 Adjusting options

TYPE	CODE	DESCRIPTION
For VMP 02		
G	-	Standard, screw type
V	4VL2307000	Handwheel
X	4COP116420	Antitamper cap
For MC08, VMP 5, VMP 10 and VMPP 45 valves		
S	-	Standard with blind nut
V	4VL2407100	Handwheel
X	4COP120420	Antitamper cap
For VMP 20 valve		
S	-	Standard with blind nut
V	4VL2407101	Handwheel
X	4AC6102800	Antitampering cap
For VMPP 10 and VMPP 20 valves		
W	-	Standard, screw type
V	XVOL105140	Handwheel
Z	5COP120420	Antitamper kit

Rating diagrams

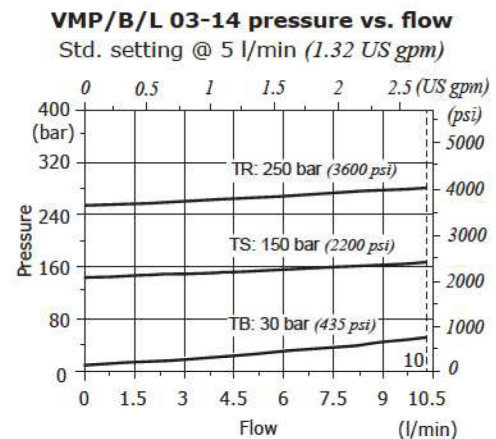
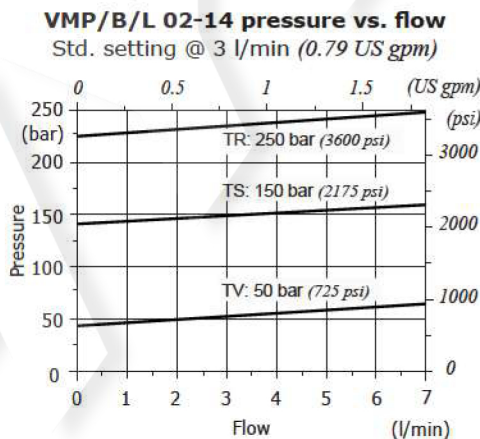

Rating diagrams

VMP/B/L 5 38-12 pressure vs. flow
Std. setting @ 5 l/min (1.32 US gpm)

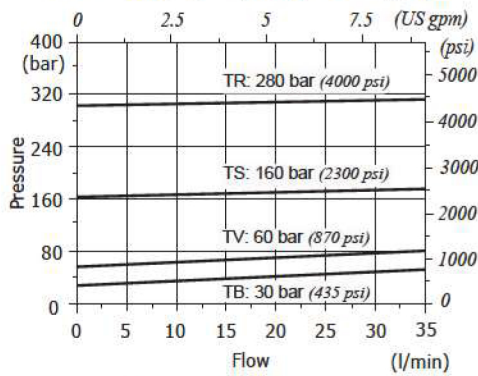

VMP/B/L 5Y 38-12 pressure vs. flow
Std. setting @ 5 l/min (1.32 US gpm)

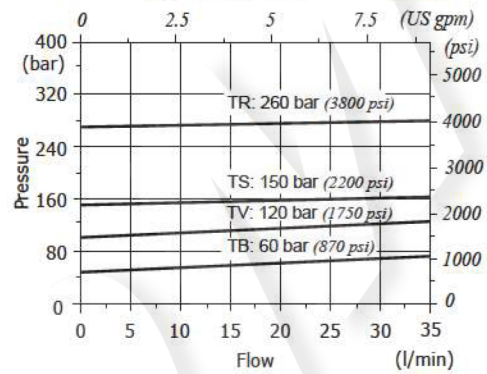

VMP/B/L 10 12-34 pressure vs. flow
Std. setting @ 5 l/min (1.32 US gpm)

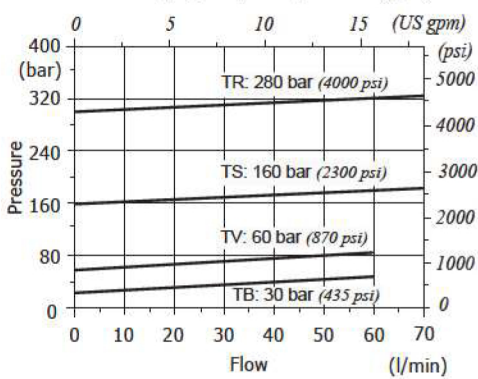

VMP/B/L 20 34-100 pressure vs. flow
Std. setting @ 5 l/min (1.32 US gpm)

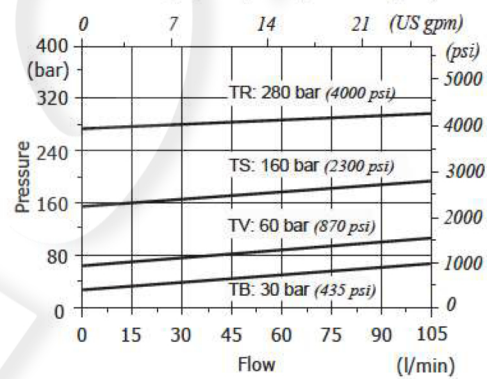

VMPP/B/L 10-12 pressure vs. flow
Std. setting @ 10 l/min (2.64 US gpm)

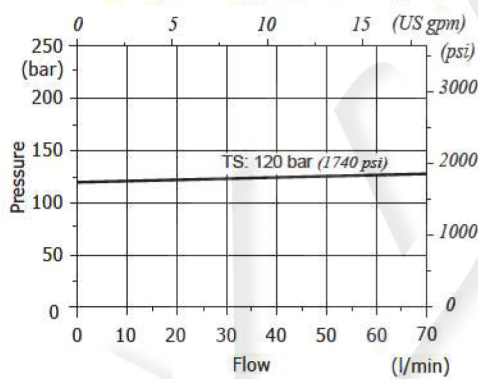

VMPP/B/L 20 34-100 pressure vs. flow
Std. setting @ 10 l/min (2.64 US gpm)

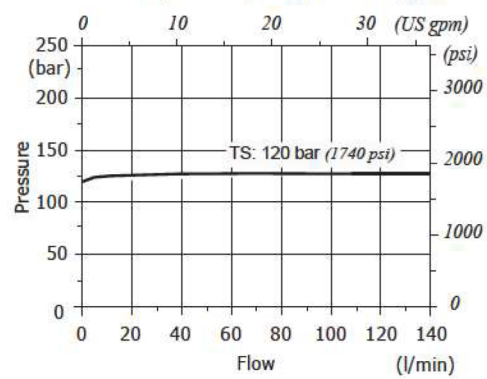

VMPP/B/L 45-114 pressure vs. flow
Std. setting @ 5 l/min (1.32 US gpm)

