

Part number:

Industrial Products

Pumps

Sizes 63, 112, 180,
280, 180DT & 280DT
Up to 510 kW and
350bar @1500 rpm

Swash-plate
Axial Piston Pump
Series K3VG

Data Sheet
P-1001/07.99
GB

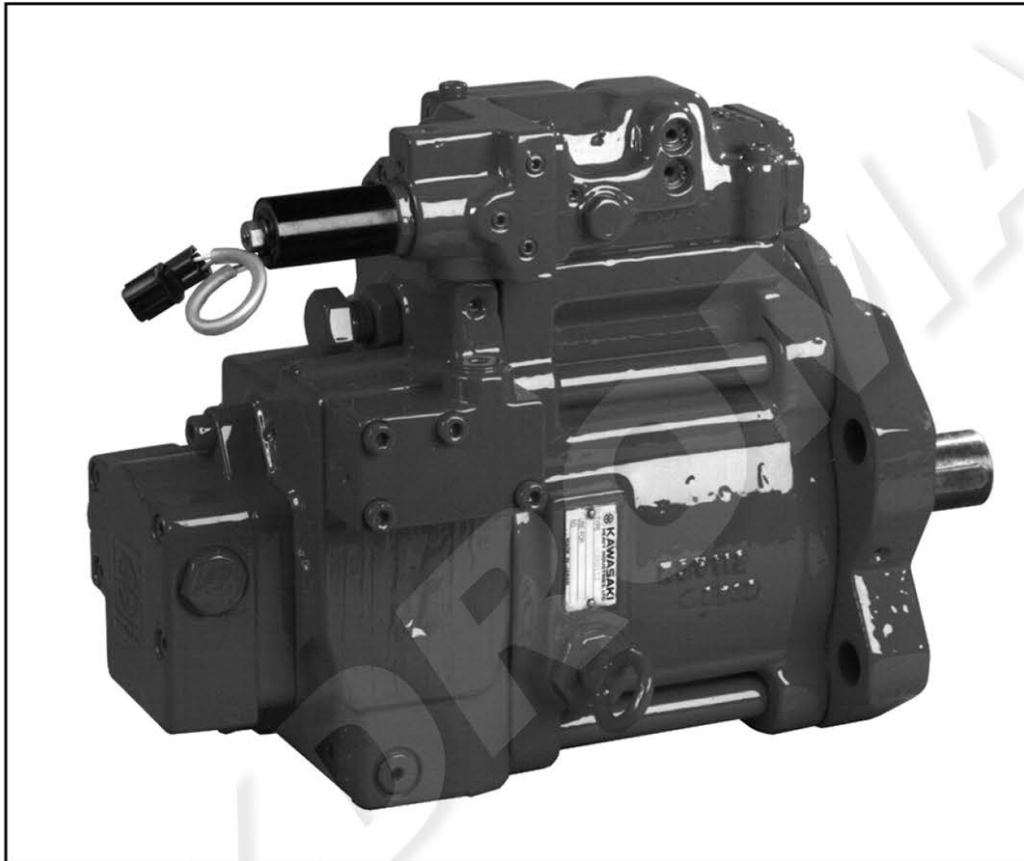

Features

- ◇ Reliable, High Pressure, Long Life Modular Design.
- ◇ Low Noise and High Efficiency.
- ◇ Self-Compensating piston return mechanism.
- ◇ Extensive Range of Highly Responsive Control Options.
- ◇ Auxiliary Gear Pump Option.
- ◇ Rated Pressure 350 Bar.
- ◇ Peak Pressure 400 Bar.
- ◇ High Continuous Power Rating.
- ◇ Fully Balanced Spherical Valve Plate.
- ◇ Infinite displacement control.
- ◇ Hydrostatically Balanced Swash Plate Support.
- ◇ High Load Capacity Bearings.

General Description

The K3VG Series Swash Plate Type Axial Piston Pumps are designed to specifically satisfy the industrial open circuit market where noise, efficiency, controllability and extended pump life are considered to be essential. K3VG Pumps are available in nominal displacements ranging from 63 to 560 cm³/rev with various pressure, displacement, and combination load sensing control options.

Model
K3VG

Page
1.34

Data Sheet
P1001/07.99

Technical Data

For applications outside the following parameters, please consult Kawasaki Precision Machinery (UK) Ltd.

Hydraulic Data

Pressure Fluid

Mineral oil, phosphate ester, fatty acid ester and water glycol.
Phosphate ester is only suitable for use with FPM seals.

Use a high quality, anti-wear, mineral based hydraulic fluid when the pressure exceeds 207 bar. In applications where fire resistant fluids are required consult Kawasaki Precision Machinery (UK) Ltd. The following chart illustrates the effects on pump life when non-standard fluids are used:

	Fluid Type			
	Mineral Oil	Phosphate Ester	Polyol Ester	Water Glycol *
Maximum continuous Pressure (bar)	350			207
Temperature Range (°C)	-20 ~ +80	0 ~ +60	0 ~ +60	10~50
Cavitation Resistance	#	●	●	●
Percentage pump life compared to mineral oil	100	60~100	50~100	20~80

= Optimum

● = Acceptable but with reduced pump life

* = DO NOT EXCEED THE RATED SPEED. Maximum speed for 280cc pumps using water glycol is 1500 rpm.

System cleanliness

Maximum permissible degree of contamination of fluid is to NAS 1638 class 9 or ISO 4466/1986 code 18/15. Kawasaki recommend a filter with a retention rate of $\beta_{10} \geq 75$.

Viscosity Range

Nominal operating range 10 to 200 cSt (For fluids over 200 cSt contact Kawasaki Precision Machinery (UK) Ltd).

Model
K3VG

Page
2.34

Data Sheet
P1001/07.99

Technical Data (continued)

For applications outside the following parameters, please consult Kawasaki Precision Machinery (UK) Ltd.

Pump Model	63	112	180	280	180DT	280DT
Displacement cm ³ /rev	63	112	180	280	360	560
Rated Pressure ⁽¹⁾ bar	350	350	350	350	350	350
Peak Pressure ⁽²⁾ bar	400	400	400	400	400	400
Rated Power (kW)	70	125	200	255	405	510
Max Flow (@ rated speed) l/min	106	193	310	390	621	780
Rated Speeds at suction pressures >or = to -0.1 bar rpm	1800	1800	1800	1500	1800	1500
Maximum operating Speeds at suction pressures >or = to +1 bar rpm	3250	2700	2300	2000	2300	2000
Mass kg	48	68	86	160	160	300

NOTES: ⁽¹⁾ Pressure at which life and durability of the pump will not be affected.

⁽²⁾ Pressure at which functionality of pump is not affected but life and durability will be shortened. Please contact Kawasaki for recommendations.

CAUTIONS!

1. Make sure the pump case is filled with clean, filtered fluid of the type used in the system before operation.
2. The pump case must be full at all times to ensure lubrication of the internal components.
3. When installing the tandem pumps (K3VG180DT and K3VG280DT) make sure that both the front and rear pumps are filled with oil through both case drain ports.

Model K3VG	Page 3.34	Data Sheet P1001/07.99	
---------------	--------------	---------------------------	--

Ordering Code – K3VG Series Variable Displacement, Axial Piston, Open Loop Pump

K3VG **180DT** **-** **1** **O** **N** **R** **-** **1PM1** **0** **1**

K3VG Series Pump

Maximum displacement

Single type:

63	63 cm ³ /rev
112	112 cm ³ /rev
180	180 cm ³ /rev
280	280 cm ³ /rev

Tandem type:

180DT	360 cm ³ /rev
280DT	560 cm ³ /rev

Hydraulic Fluid Type

-	Mineral oil
W	Water glycol
Z	Phosphate ester

Circuit type

1	Open Loop
---	-----------

Gear Pumps, Gear Pump mounting provision and Pressure Assist Options

- 0 Without gear pump. Without pressure assist port.
- 1 10 cm³/rev with built in relief valve 40 bar setting (50 bar max) (not available on tandem)
- 2 15 cm³/rev with built in relief valve 40 bar setting (50 bar max) (not available on tandem)
- 3 Without gear pump, with pressure assist port
- 6 With pressure assist port. With mounting provision for customer supplied gear pump with SAE 'A' mounting and 13 tooth spline. (refer to page 27)
- 7 Without pressure assist port. With mounting provision for customer supplied gear pump with SAE 'A' mounting and 13 tooth spline. (refer to page 27)
- A SAE 'B' mounting provision for 280, 180DT and 280DT only (refer to page 27)

Auxiliary Gear Pump ((Tandem Units only)

Blank Without pump
1 With pump:
(Refer to gear pump arrangements on Page 5)

Confluent Block ((Tandem Units only)

Blank Single pump
0: Tandem Pumps without confluent block
R: Rear Outlet Type
S: Side Outlet Type

Regulator Ordering Code

See Page 5.

Mounting Orientation

-	Standard Horizontal Mounting
V	Vertical Mounting (shaft up only)

Direction of Rotation (Viewed from shaft end)

R	Clockwise
L	Counterclockwise (Tandem only)

Mounting Bracket/Port Flanges

N: No bracket, no flange
0: Without bracket, with flange
F: With bracket, with flange
B: With bracket, without flange

Model
K3VG

Page
4.34

Data Sheet
P1001/07.99

Ordering Code – Regulator

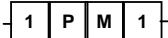

Power/Pressure Control

- 0 Without Power or Pressure Control.
- 1 Power Control.
- 4 Pressure Compensation.
- 7 Power Control and Pressure Compensation

Power Setting Code

- 0 No Power Control.
- 1-4} See Power Setting Codes on Pages 7 & 8

Displacement Control

- 0 Without Displacement Control.
- P Positive Displacement Control.
- N Negative Displacement Control.
- E Electrical positive displacement control.
- L Load Sense.

Power Control Mode

- H High Power Band.
- M Medium Power Band.
- L Low Power Band.
- 0 No Power Control.

Standard Gear Pump Arrangements

Pump Size and Ordering Code	Gear Pump Displacement
K3VG 63 - 1 1 # # - ####	10 cm ³ /rev
K3VG 112 - 1 1 # # - ####	10 cm ³ /rev
K3VG 180 - 1 1 # # - ####	10 cm ³ /rev
K3VG 280 - 1 2 # # - ####	15 cm ³ /rev
K3VG 180DT - 1 A # # - #### # 1	25.3 cm ³ /rev
K3VG 280DT - 1 A # # - #### # 1	32.5 cm ³ /rev

Note: The "#" denotes any available selection for the pump - See the [Ordering Code for the Pump](#).

Model K3VG	Page 5.34	Data Sheet P1001/07.99
---------------	--------------	---------------------------

Summary of Control Options

Power/Pressure Control Code	Displacement Control Code	Description
0	P	Infinitely variable positive displacement control by pilot pressure
0	N	Infinitely variable negative displacement control by pilot pressure
0	E	Infinitely variable positive displacement control by Electrical Proportional Valve
1	0	Power control with maximum displacement stop
1	P	Power and positive displacement control by pilot pressure
1	N	Power and negative displacement control by pilot pressure
1	E	Power and positive electrical displacement control
4	0	Pressure compensation
4	L	Load sense control
7	0	Power and pressure compensation
7	P	Power, pressure compensation and positive displacement control
7	N	Power, pressure compensation and negative displacement control
7	E	Power, pressure compensation and electrical positive displacement control
7	L	Power control and Load sensing. (also available with a combined displacement control option)

Note:

When using displacement control at pump delivery pressures below 40bar, a pressure assist signal is required to maintain adequate response.

The pressure assist signal can be provided by either an attached gear pump or an external source.

The optional attached gear pump is recommended for use with all displacement control options.

All displacement control hydraulic circuit diagrams illustrate the attached gear pump.

Model
K3VG

Page
6.34

Data Sheet
P1001/07.99

Power Setting Codes

Standard Regulator code at 1500 rpm - pumps without auxiliary gear pump

Motor Power kW	K3VG Pump Frame Size					
	63	112	180	280	180DT	280DT
11	L4					
15	L1					
18.5	M2					
22	M1	L3				
30	H2	M3	L3			
37		M1	L1			
45		H5	M4			
55		H3	M2	L2		
75			H4	M4	L2	
90			H2	M2	M4	
110				H4	M2	L3
132				H2	H4	L1
160					H2	M3
200						M1
250						H4
280						H2

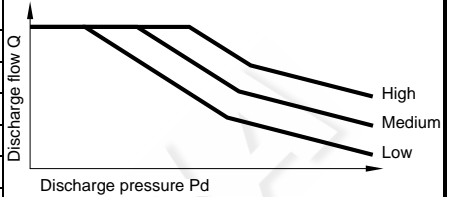

Example 1 Without gear pump:

Pump: K3VG112-10NR-10??
 Electric Motor: 22 kW at 1500 rpm
 Power Set Code: L3
 Final Mode/Code: K3VG112-10NR-10L3

Power Adjustment Range

The power setting can be adjusted via external adjusting screws. The adjustment range of the power control settings at 1500 rpm is given in the table below.

Power control settings (kW) at 1500 rpm						
Pump model	K3VG63	K3VG112	K3VG180	K3VG280	K3VG180DT	K3VG280DT
H - High Power	22.0~33.8	37.0~62.1	55.0~96.5	90.0~150.1	109.4~192.9	197.3~300.3
M - Medium Power	15.6~22.4	27.1~45.6	43.9~75.0	67.3~113.5	87.9~134.5	137.2~239.2
L - Low Power	10.6~18.9	19.1~30.7	29.9~45.6	46.8~75.0	59.9~91.1	93.5~160.0

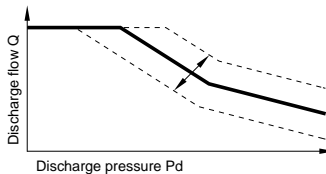

Note:

For additional speed and power settings contact Kawasaki Precision Machinery (UK) Ltd.

Model K3VG	Page 7.34	Data Sheet P1001/07.99	
---------------	--------------	---------------------------	--

Functional Description of Regulator

Key to Hydraulic Circuit Annotations	
Annotation	Description
A ₁	Main pump delivery
A ₂	Auxiliary pump delivery
a ₁	Gauge port main pump delivery
a ₂	Gauge port auxiliary pump delivery
B ₂	Gear pump suction
B ₁	Main pump suction
b	Suction gauge port
Dr	Drain
Pi	Pilot pressure
Pc	Remote Pilot Port, Pressure Compensator
Pi	Pilot Port Displacement Control
P _L	Load sense port
Psv	Pressure Assist Port

Note: The optional attached gear pump is recommended for all displacement control options. Hydraulic circuit diagrams illustrate the attached gear pump

Regulator Code	Control Curves	Hydraulic Circuit
<p>OP Variable Delivery positive displacement control</p> <p>Infinitely variable adjustment of the delivery flow is possible by the pilot hydraulic pressure.</p> <p>An increase in pilot signal will result in an increase in displacement, hence the positive control.</p>	<p>Range of Displacement Control 2.5 - 100%</p>	

Functional Description of Regulator (continued)

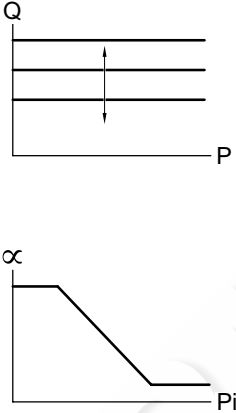
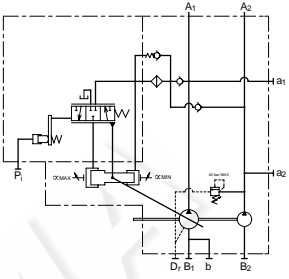
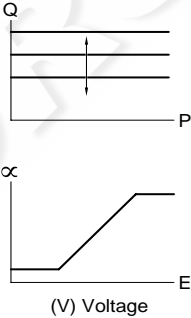
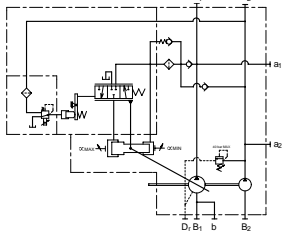
Regulator Code	Control Curves	Hydraulic Circuit
<p>ON Variable delivery negative displacement control</p> <p>Infinitely variable adjustment of the delivery flow is possible by the pilot hydraulic pressure.</p> <p>An increase in pilot signal will result in an decrease in displacement, hence the negative control.</p>	 <p>Range of displacement control 15 – 100%</p>	
<p>OE Variable Delivery Electrical Displacement Control</p> <p>Infinitely variable adjustment of the delivery flow is possible by using the pilot voltage. (Utilising a solenoid operated proportional pressure reducing valve). The pilot voltage is used as a power source for the solenoid operated proportional pressure reducing valve; a 10cc gear pump is available which eliminates redundant external piping. This regulator requires an amplifier to provide the electrical signal.</p>	 <p>(V) Voltage</p> <p>Range of displacement control 2.5 – 100%</p>	

Model K3VG	Page 9.34	Data Sheet P1001/07.99	
---------------	--------------	---------------------------	--

Functional Description of Regulator (continued)

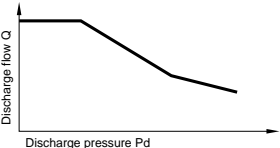
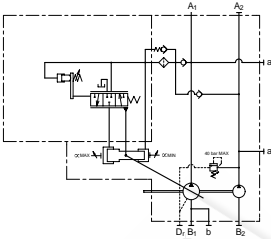
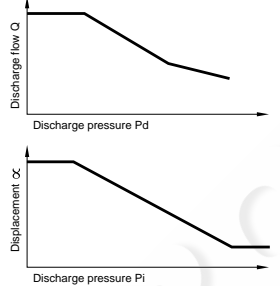
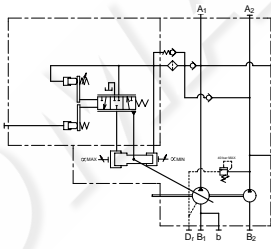
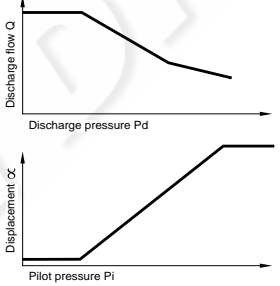
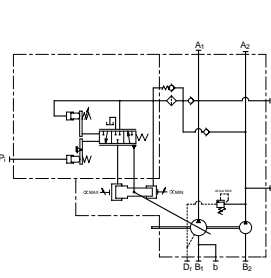

Regulator Code	Control Curves	Hydraulic Circuit
<p>10## Power Control</p> <p>In response to a rise in delivery pressure, the swash-plate tilting angle is decreased, limiting the input torque. This regulator prevents excessive load against the prime mover.</p>		
<p>1N Power and Negative Displacement Control</p> <p>In response to a rise in delivery pressure, the swash-plate tilting angle is decreased, limiting the input torque. This regulator prevents excessive load against the prime mover. By adding a pilot signal to the Pi port the discharge flow can be infinitely adjusted within the range of the pump. An increase in pilot signal will result in a decrease in flow, hence the Negative control.</p>	 <p>Range of Displacement control 15-100%</p>	
<p>1P Power and Positive Displacement control</p> <p>This regulator combines the Power Control with Positive Displacement control. By adding a pilot signal to the Pi port the discharge flow can be infinitely adjusted within the range of the pump. An increase in pilot signal will result in an increase in flow, hence the Positive control.</p>	 <p>Range of Displacement control 2.5-100%</p>	

Model
K3VG

Page
10.34

Data Sheet
P1001/07.99

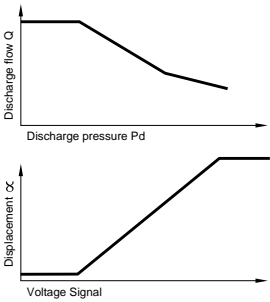
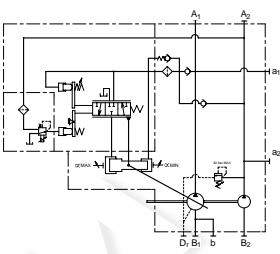
Functional Description of Regulator (continued)

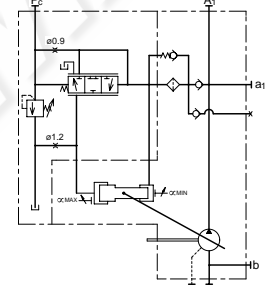
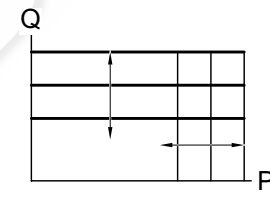
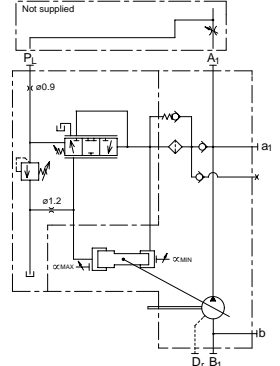
Regulator Code	Control Curves	Hydraulic Circuit
<p>1E Power and Electrical Displacement control</p> <p>This regulator combines the Power Control with Electrical Displacement control. A proportional reducing valve is added to the regulator so the discharge flow can be infinitely adjusted within the range of the pump. An increase in electrical signal to the proportional reducing valve will result in an increase in flow. This regulator requires an amplifier to provide the electrical signal.</p>	 <p>Range of Displacement control 2.5-100%</p>	
<p>4000 Pressure Compensated Control</p> <p>This regulator maintains a constant pressure regardless of the discharge flow. It is imperative that a safety relief valve is installed in the circuit.</p> <p>Note: Standard factory pressure setting is 200 bar with an adjustable range of 80 bar to 315 bar. For pressure settings above 315 bar please state clearly on the order.</p>	 <p>Range of Displacement control 0-100%</p>	
<p>4L00 Pressure Compensation and Load Sense Control</p> <p>This regulator controls the pump displacement to match the flow requirement as a function of the load sensing differential pressure with a factory setting of 25 bar Δp. Also provides the facility for pressure limiting.</p> <p>Note: Standard factory pressure setting is 200 bar with an adjustable range of 80 bar to 315 bar. For pressure settings above 315 bar please state clearly on the order.</p>	 <p>Range of Displacement control 0-100%</p>	
<p>Model K3VG</p>	<p>Page 11.34</p>	<p>Data Sheet P1001/07.99</p>

Functional Description of Regulator (continued)		
Regulator Code	Control Curves	Hydraulic Circuit
<p>70 Power and Pressure Compensation</p> <p>This regulator combines the Power with Pressure Compensated Control.</p> <p>Note: Standard factory pressure setting is 200 bar with an adjustable range of 80 bar to 315 bar. For pressure settings above 315 bar please state clearly on the order.</p>		
<p>7N Power, Pressure Compensation and Negative Displacement control</p> <p>This regulator combines the Power Control with Pressure Compensated Control. By adding a pilot signal to the Pi port the discharge flow can be infinitely adjusted within the pump range. An increase in pilot signal will result in a decrease in flow, hence the Negative control.</p> <p>Note: Standard factory pressure setting is 200 bar with an adjustable range of 80 bar to 315 bar. For pressure settings above 315 bar please state clearly on the order.</p>	<p>Range of Displacement control 100-15%</p>	
<p>Model K3VG</p>	<p>Page 12.34</p>	<p>Data Sheet P1001/07.99</p>

Functional Description of Regulator (continued)

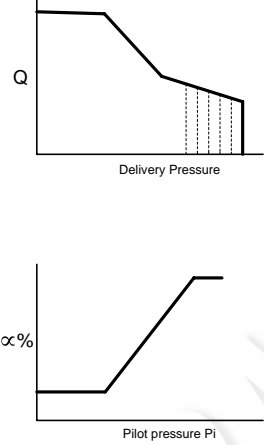
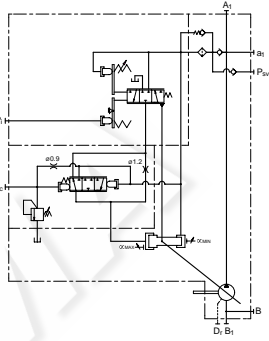
Regulator Code	Control Curves	Hydraulic Circuit
<p>7P Power, Pressure Compensation and Positive Displacement control</p> <p>This regulator combines the Power Control with Pressure Compensation Control. By adding a pilot signal to the Pi port the discharge flow can be infinitely controlled within the range of the pump displacement. An increase in pilot signal will result in an increase in flow, hence the Positive control.</p> <p>Note: Standard factory pressure setting is 200 bar with an adjustable range of 80 bar to 315 bar. For pressure settings above 315 bar please state clearly on the order.</p>	 <p>Range of Displacement control 2.5-100%</p>	

Model K3VG	Page 13.34	Data Sheet P1001/07.99	
---------------	---------------	---------------------------	--

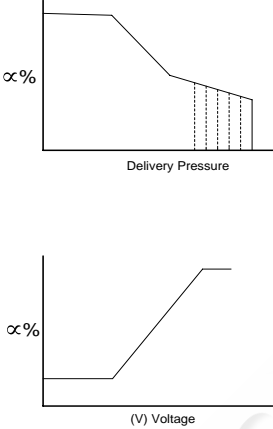
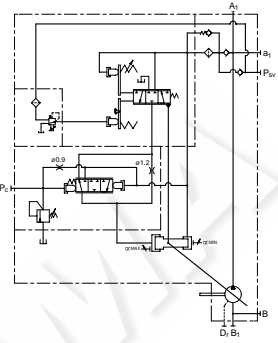
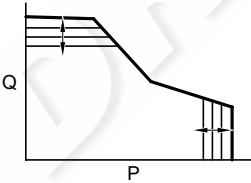
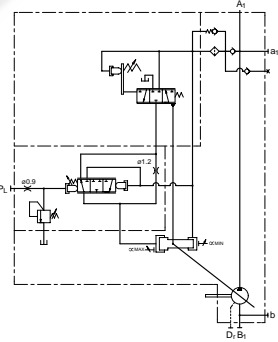
Functional Description of Regulator (continued)		
Regulator Code	Control Curves	Hydraulic Circuit
<p>7E Power, Pressure Compensation and Electrical Displacement control</p> <p>This regulator combines the Power Control with Pressure Compensation and Electrical Displacement control. A proportional reducing valve is added to the regulator so the discharge flow can be infinitely adjusted within the pump range. An increase in electrical signal to the proportional reducing valve results in an increase in flow. This regulator requires an amplifier to provide the signal.</p> <p>Note: Standard factory pressure setting is 200 bar with an adjustable range of 80 bar to 315 bar. For pressure settings above 315 bar please state clearly on the order.</p>	 <p>Range of Displacement control 2.5-100%</p>	
<p>7L Power, Pressure Compensation and Load Sense Control</p> <p>This regulator combines Power Control and Load Sense Control. Load sense factory setting 25 bar Δp. Adjustment range 10 to 30 bar.</p> <p>Note: Standard factory pressure setting is 200 bar with an adjustable range of 80 bar to 315 bar. For pressure settings above 315 bar please state clearly on the order.</p>	 <p>Range of Displacement control 0-100%</p>	
<p>Model K3VG</p>	<p>Page 14.34</p>	<p>Data Sheet P1001/07.99</p>

Performance Curves - K3VG63

Overall Efficiency (%)

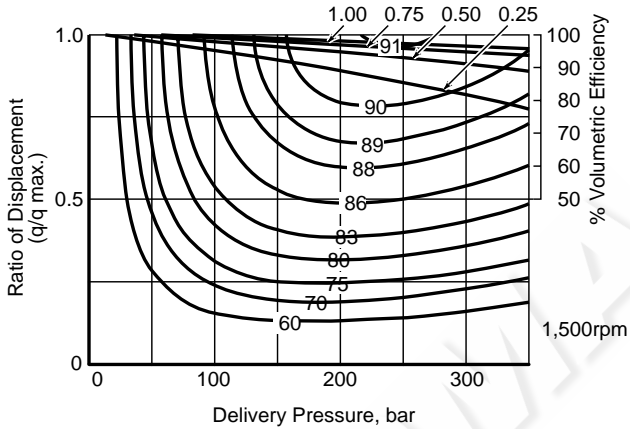

Performance Curves - K3VG112

Overall Efficiency (%)

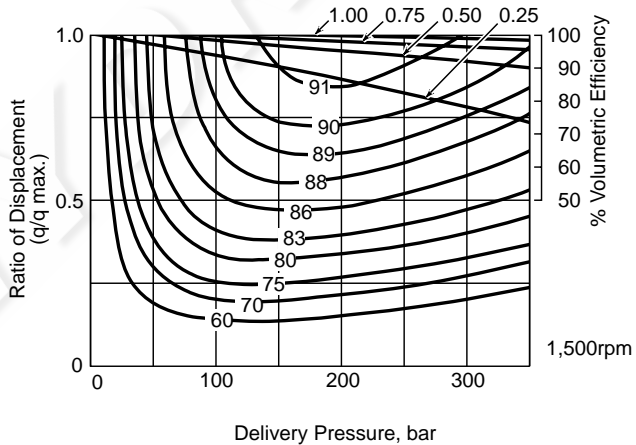

Model
K3VG

Page
15.34

Data Sheet
P1001/07.99

Performance Curves - K3VG180 and K3VG180DT

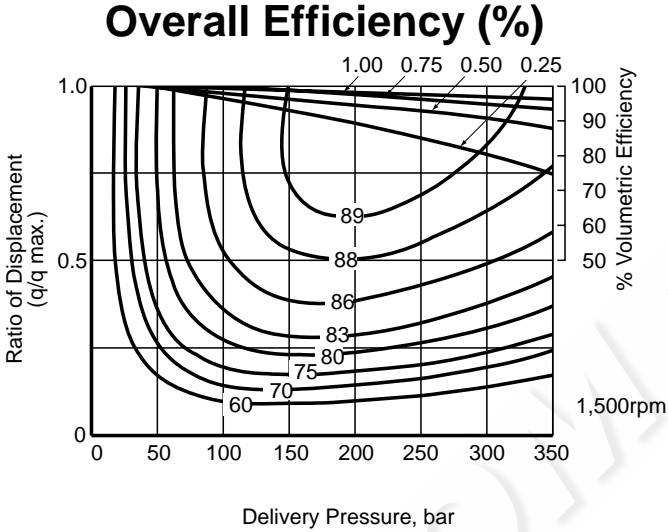

Performance Curves - K3VG280 and K3VG280 DT

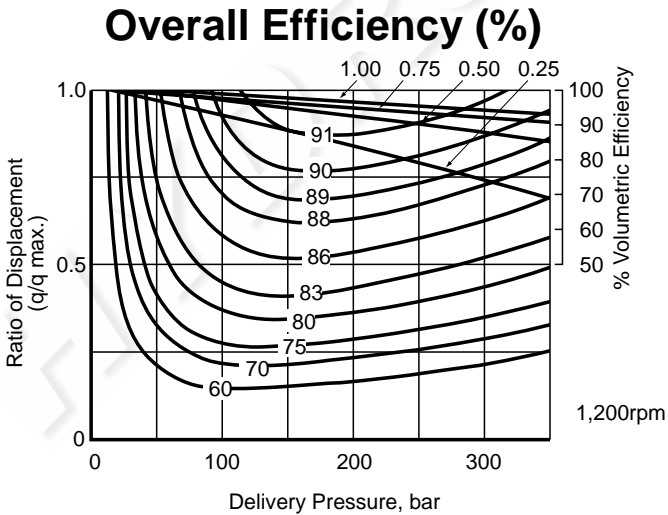

Model
K3VG

Page
16.34

Data Sheet
P1001/07.99

Displacement control Curves - K3VG63

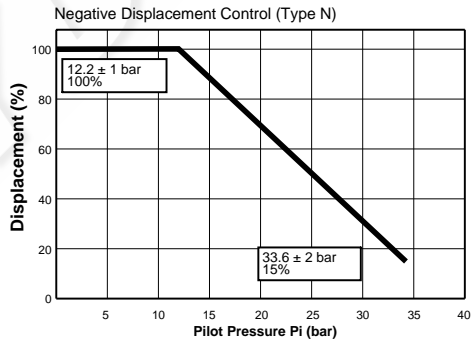
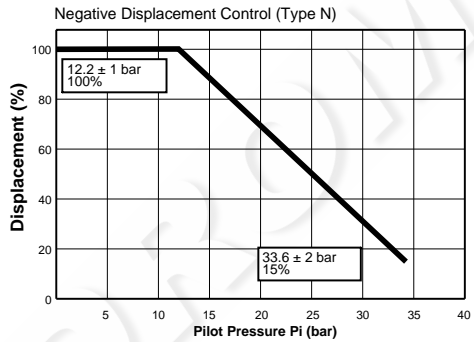
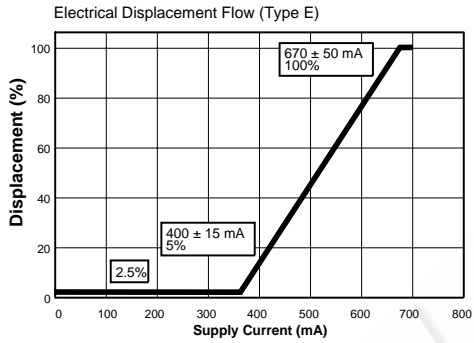

Model
K3VG

Page
17.34

Data Sheet
P1001/07.99

Displacement control Curves - K3VG112

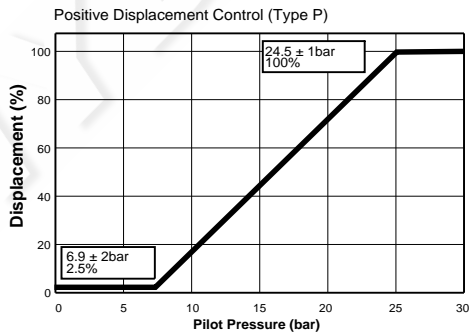
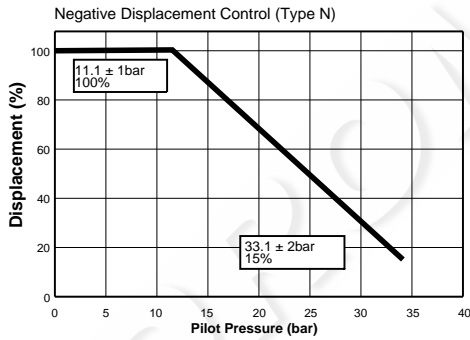
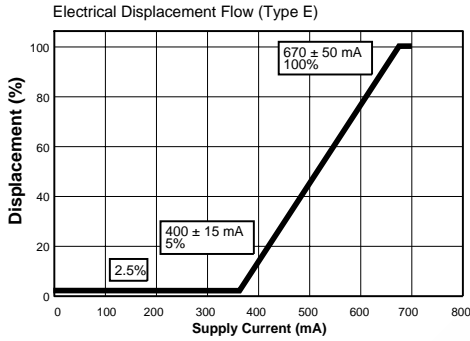

Model
K3VG

Page
18.34

Data Sheet
P1001/07.99

Displacement control Curves - K3VG180/180DT

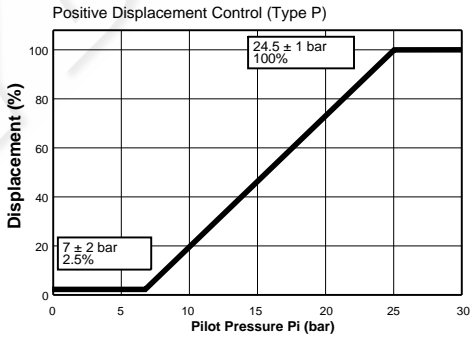
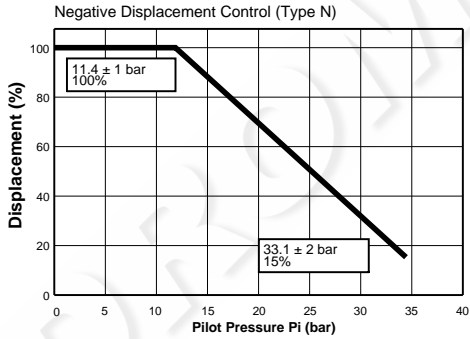
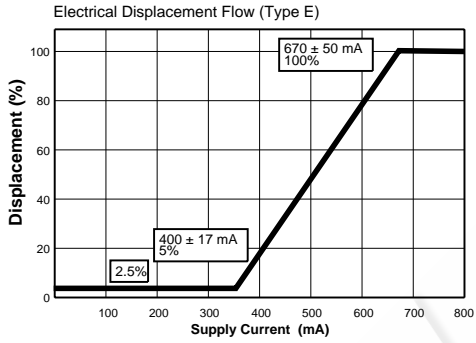

Model
K3VG

Page
19.34

Data Sheet
P1001/07.99

Displacement control Curves - K3VG280/280DT

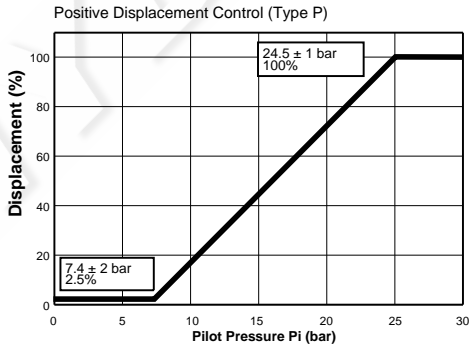
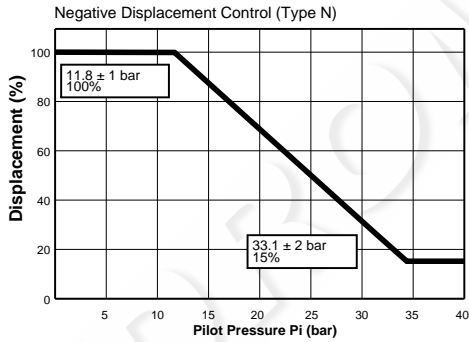
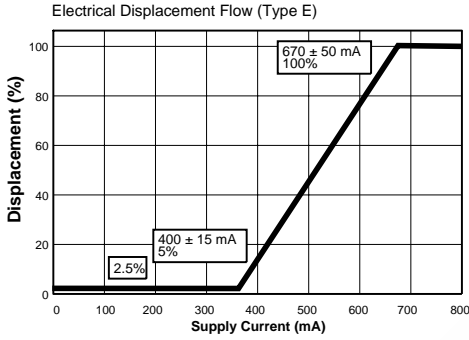

Model
K3VG

Page
20.34

Data Sheet
P1001/07.99

Installation

Recommended Pump Mounting

The pump should be mounted horizontally with the case drain piping initially rising above the level of the pump before continuing to the tank as shown in the illustration below. Do not connect the drain line to the suction line.

The uppermost drain port should be used and the drain piping should be equal or larger in size than the drain port to minimise pressure in the pump case. The pump case pressure should not exceed 2.1 bar as shown in the illustration below. (Peak pressure should never exceed 5.9 bar.)

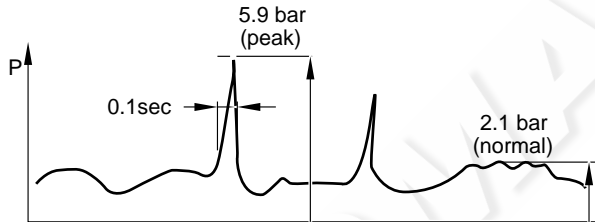

Mounting the Pump Above the Tank

If the pump is to be mounted above the level of the tank the suction line must initially rise above the level of the pump before continuing to the tank as shown in the illustration below. The maximum allowable height the pump can be mounted above the fluid level is 1 meter. The minimum suction pressure should be -0.1 bar or above.

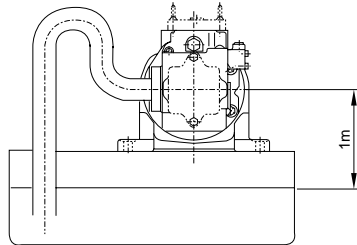
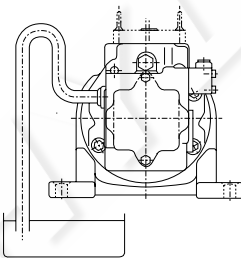

<p>Model K3VG</p>	<p>Page 21.34</p>	<p>Data Sheet P1001/07.99</p>	
-----------------------	-----------------------	-----------------------------------	--

Installation (continued)**Mounting the Pump Vertically (shaft up)**

For applications requiring vertical installation (shaft up) the pump must be provided with additional means to lubricate the front bearing. Do not use a standard pump for this type of application. (Mounting orientation "V" type should be used.)

The oil level in the tank should be higher than the pump-mounting flange as shown in illustration [a] below. If the oil level in the tank is lower than the pump mounting flange then forced lubrication is required through the air bleed port 1 ~ 2 l/min.

When installing the pump in the tank and submerged in the oil, open the drain port and air bleed port to provide adequate lubrication to the internal components.

When installing the pump outside the tank run piping for the drain and air bleed ports to tank (see illustration [c]). If the drain or air bleed piping rise above the level of oil (see illustration [b]) fill the lines with oil before operation.

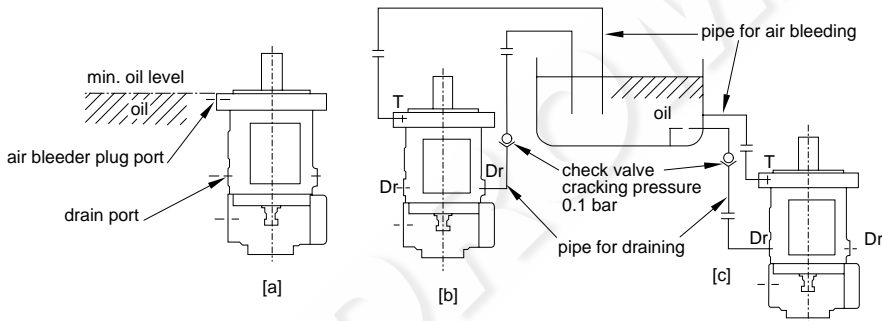

A check valve with cracking pressure of 0.1 bar should be fitted to the case drain line as shown. Recommended Kawasaki check valves are as follows: (refer to Kawasaki industrial valve information - data sheet C1001)

Model	Recommended Kawasaki check valve
K3VG 63	C10G - 10/01-*
K3VG 112	C15G - 10/01-*
K3VG 180	C15G - 10/01-*
K3VG 280	C15G - 10/01-*
K3VG 180 DT	C20G - 10/01*
K3VG 280 DT	C20G - 10/01*

Drive Shaft Coupling

Use a flexible coupling to connect the pump shaft to an engine flywheel or electric motor shaft. Alignment should be within 0.05mm TIR as shown in the illustration below.

Do not apply any radial or axial loading to the pump shaft. For applications where radial or side loads exist please contact Kawasaki Precision Machinery (UK) Ltd. for recommendations.

Do not force the coupling on or off the pump shaft. Use the threaded hole in the end of the pump shaft to fix or remove the coupling.

dial gauge (reading a)
 $\delta = a/2 \quad 0.025\text{mm}$

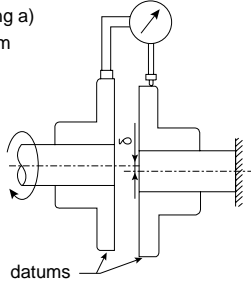

dial gauge (reading b)
 $\alpha = \text{SIN}^{-1}(b/D)$
 0.2°

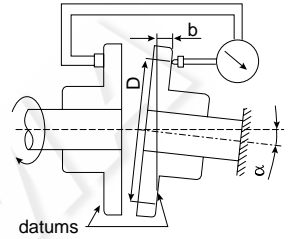

For engine drives a split type pinch bolt drive flange and flexible coupling is recommended.

Unit Dimensions – K3VG63/112/180/280

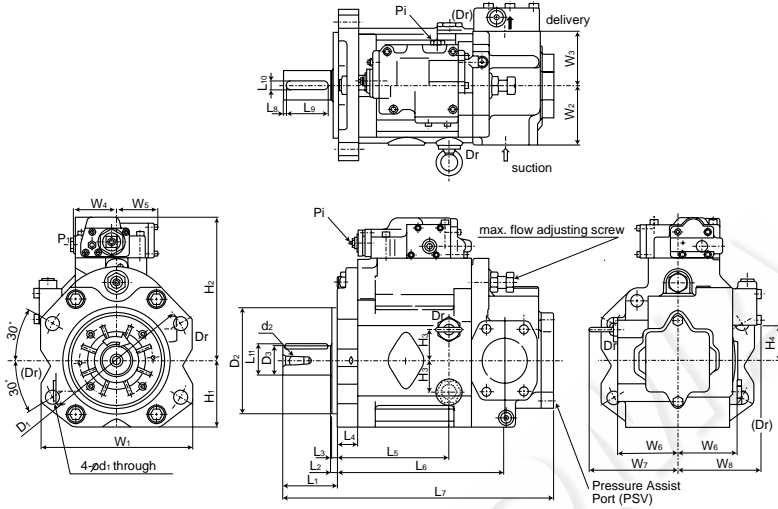

Dimensions of single pumps without gear pump (dimensions in mm)

Pump size	D ₁	D ₂	D ₃	L ₁	L ₂	L ₃	L ₄	L ₅	L ₆
63	180	125 ^{-0.050} _{-0.090}	32 ^{k6}	68	10	8	27	138	210
112	224	160 ^{-0.050} _{-0.090}	40 ^{k6}	92	10	8	33	167	249
180	250	180 ^{-0.050} _{-0.090}	50 ^{k6}	92	10	8	36	190	285
280	300	200 ^{-0.050} _{-0.090}	55 ^{k6}	92	10	8	50	203	351

Pump size	L ₇	L ₈	L ₉	L ₁₀	L ₁₁	H ₁	H ₂	H ₃	H ₄
63	349	4	50	10	35	89	195	37	41
112	419	5	70	12	43	100	220	41	49
180	466	5	70	14	53.5	112	245	53	58
280	539	5	70	16	59	127	286	70	68

Pump size	W ₁	W ₂	W ₃	W ₄	W ₅	W ₆	W ₇	W ₈	d ₁	d ₂
63	190	70	70	72	69	76	115	113	18	M12
112	234	90	80	72	69	90	138	125	22	M12
180	256	100	92	72	69	101	149	139	22	M16
280	300	120	120	72	69	118	-	167	26	M16

Model K3VG	Page 24.34	Data Sheet P1001/07.99
---------------	---------------	---------------------------

Unit Dimensions – K3VG180DT/280DT

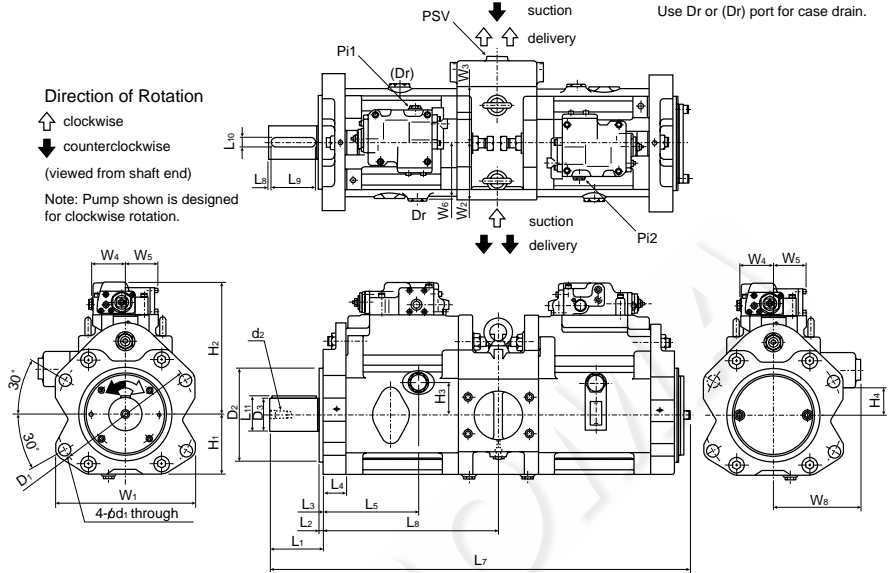

Dimensions of double pumps without gear pump (dimensions in mm)

Pump size	D ₁	D ₂	D ₃	L ₁	L ₂	L ₃	L ₄	L ₅	L ₆
180DT	250	180 ^{-0.050 -0.090}	60 ^{k6}	115	10	8	36	190	311
280DT	300	200 ^{-0.050 -0.090}	70 ^{k6}	115	10	9	50	203	374

Pump size	L ₇	L ₈	L ₉	L ₁₀	L ₁₁	H ₁	H ₂	H ₃	H ₄
180DT	786	5	95	18	64	112	245	53	51
280DT	896	5	95	20	74.5	127	286	70	59

Pump size	W ₁	W ₂	W ₃	W ₄	W ₅	W ₆	W ₈	d ₁	d ₂
180DT	256	100	100	72	69	101	165	22	M16
280DT	300	120	120	72	69	118	185	26	M16

Model K3VG	Page 25.34	Data Sheet P1001/07.99
---------------	---------------	---------------------------

Unit Dimensions – Drain Port (dimensions in mm)**Dimensions of drain ports in mm**

Pump size	a	b	c	d
63	PF $\frac{1}{2}$	22.6	2.5	19
112	PF $\frac{3}{4}$	30.8	3.5	20
180, 180DT	PF $\frac{3}{4}$	30.8	3.5	20
280, 280DT	PF $\frac{3}{4}$	30.8	3.5	20

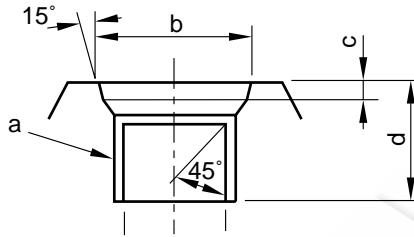
**Additional Porting Information**

Port	Size
Pc and P _i for 4000 regulators	$\frac{1}{4}$ BSPT
Pc and P _i for type 7 regulators	$\frac{1}{4}$ PF
Pi type P displacement control	$\frac{1}{4}$ PF
All gauge ports	$\frac{1}{4}$ PF
Vertical mount air bleed 63, 112, 180 cc displacements	$\frac{1}{8}$ PF
Vertical mount air bleed 280 cc displacements	$\frac{1}{4}$ PF

Additional 'O' Ring Information

Port Size	'O' Ring Size	Hardness	KPM Part Number
PF $\frac{1}{8}$ "	7.8 ID x 1.90 sec	90 shore	00RBP8
PF $\frac{1}{4}$ "	10.8 ID x 2.4 sec	90 shore	00RBP11
PF $\frac{1}{2}$ "	17.8 ID x 2.4 sec	90 shore	00RBP18
PF $\frac{3}{4}$ "	23.7 ID x 3.5 sec	90 shore	00RBP24

Model
K3VGPage
26.34Data Sheet
P1001/07.99

Unit Dimensions – Mounting Provisions for Attaching Gear Pumps (dimensions in mm)

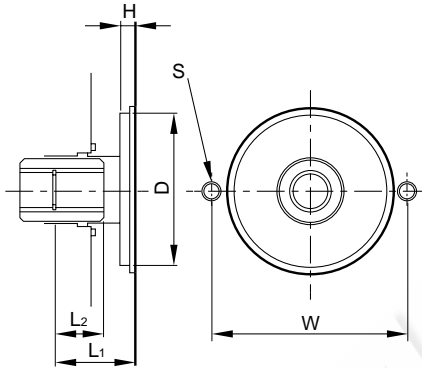

Size		63, 112, 180, 280	280, 180DT, 280DT
Install form code	Without assist pressure port	7	A
	With assist pressure port	6	
Dimensions (Rule SAE"A" for 63, 112, 180 and 280) (Rule SAE"B" for 280, 180DT and 280DT)	D	82.5	101.6
	H	8	11
	W	106	146
	S	2-M10 depth 16	2-M12 depth 20
	L ¹	43	43
	L ²	26	26
Dimensions of Spline	Rule	SAE flat root, side fit	
	Number of teeth	13	13
	Diametral pitch	16/32	
	Pressure angle	30 ⁰	
	Root diameter	22.225 ^{+0.279} ₀	22.225 ^{+0.279} ₀
	Measurement over pins	16.589 ⁰ _{-0.067}	16.589 ⁰ _{-0.067}
	Pin diameter	2.743	
Allowable max.torque (Nm)		214	214

Model K3VG	Page 27.34	Data Sheet P1001/07.99	
---------------	---------------	---------------------------	--

K3VG Regulators

Type 1 Power control, Positive & negative displacement control

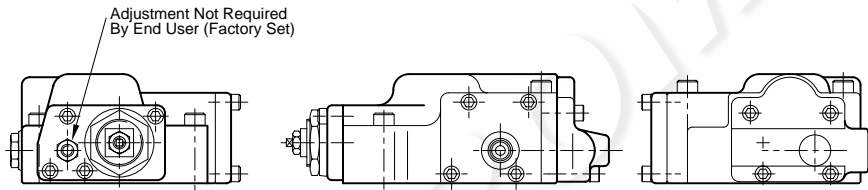
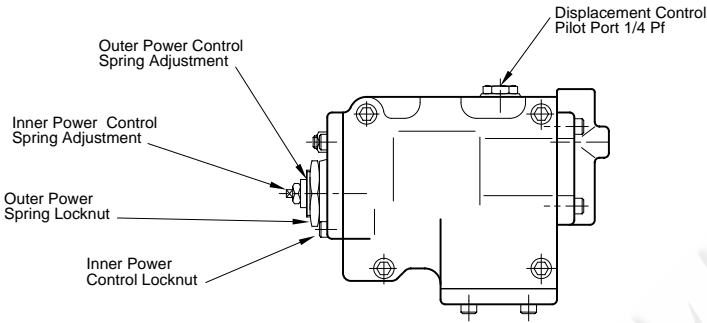

Type 4L Load sense & pressure limiting control

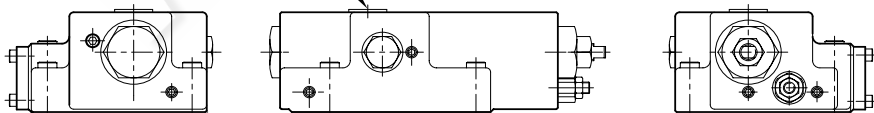
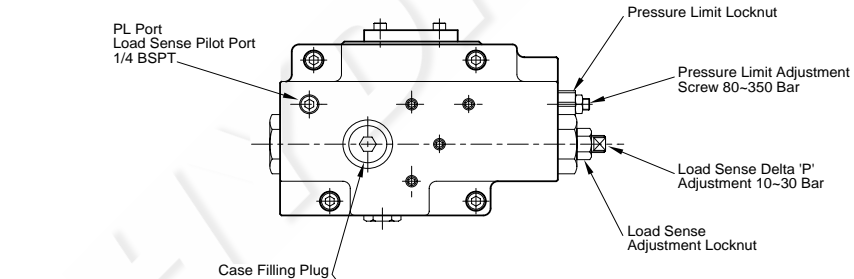

Model
K3VG

Page
28.34

Data Sheet
P1001/07.99

K3VG Regulators (continued)

Type 7 Power control, Negative or positive displacement control, Pressure compensating or load sense control

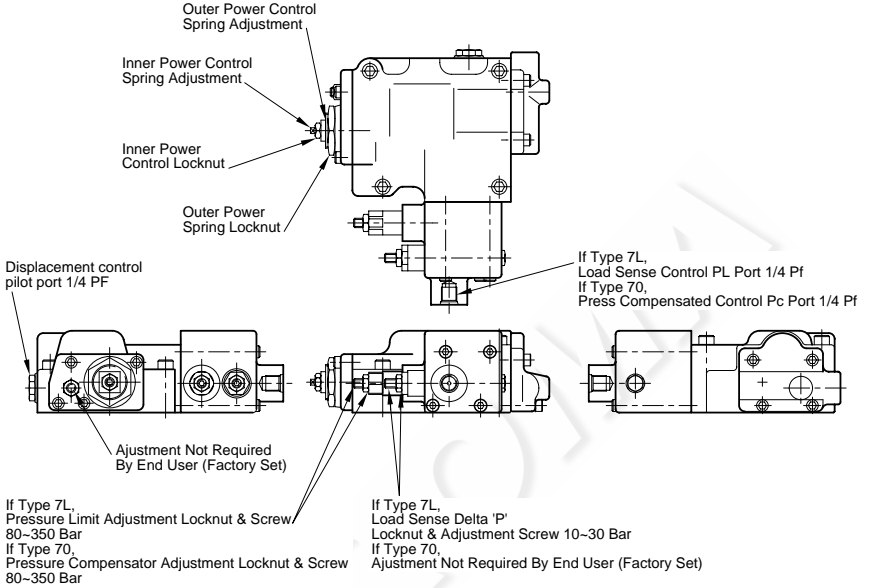

Type 4 Pressure compensator control

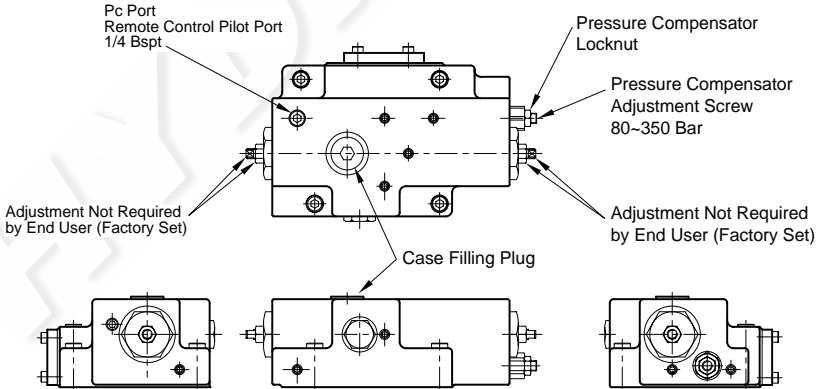

Model K3VG	Page 29.34	Data Sheet P1001/07.99	
---------------	---------------	---------------------------	--

Unit Dimensions – Foot Bracket (Accessory) (dimensions in mm)

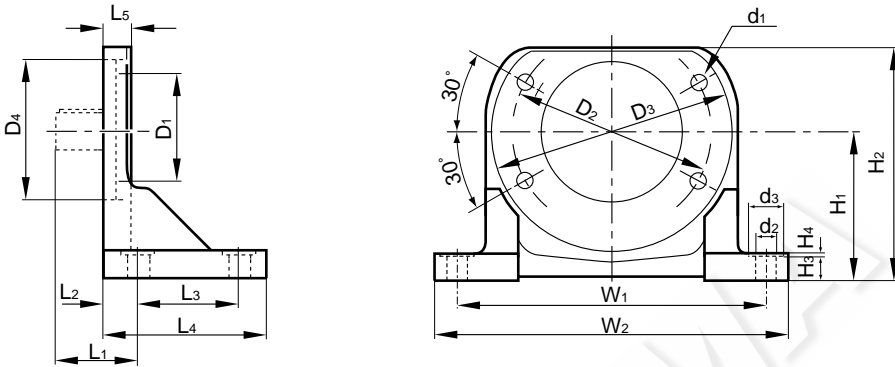

Dimensions in mm

Pump size	D ₁	D ₂	D ₃	D ₄	L ₁	L ₂	L ₃	L ₄	L ₅
63	125	180	214	-	75	32	93	150	25
112	160	224	264	-	100	38	112	180	30
180	180	250	290	-	100	44	132	212	36
280	200	300	340	250	100	50	400	500	42
180DT	180	250	290	204	123	44	320	400	36
280DT	200	300	340	250	123	50	400	500	42

Pump size	H ₁	H ₂	H ₃	H ₄	W ₁	W ₂	d ₁	d ₂	d ₃
63	132	207	22	3	280	320	M16	18	32
112	160	252	27	3	335	384	M20	22	40
180	180	284	33	3	375	428	M20	22	40
280	225	358	39	3	450	520	M24	34	60
180DT	200	304	33	3	375	428	M20	22	40
280DT	225	358	39	3	450	520	M24	34	60

Unit Dimensions – Flange Accessory for Delivery Port (SAE code 62) (dimensions in mm) (continued)**Delivery Port Flange When Using Confluent Block**

Pump size	l ₁	l ₂	l ₃	l ₄	l ₅	d ₁	d ₂	d ₃	d ₄
180DT	40	90	44.5	86	96.8	65	51	43.1	60.5
280DT	40	90	44.5	86	96.8	65	51	43.1	60.5

Pump size	d ₅	d ₆	d ₇	SAE Pipe Size	Screw Size
180DT	71	140	22	2	M20-65
280DT	71	140	22	2	M20-65

Model
K3VGPage
32.34Data Sheet
P1001/07.99

Unit Dimensions – Suction and delivery port (dimensions in mm)

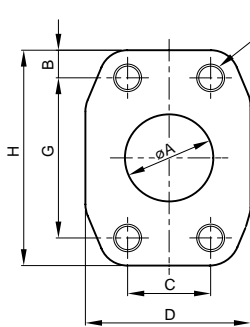

SUCTION PORT

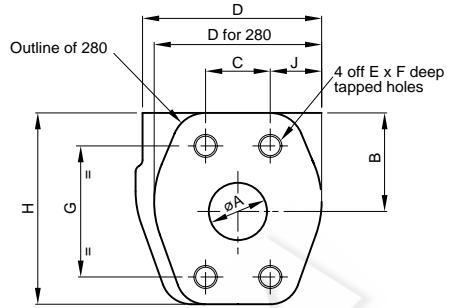

DELIVERY PORT

Delivery Port

Size	A	B	C	D	E	F	G	H	J
63	25	41	27.8	77	M10 x 1.5	18	57.2	83.5	22
112	32	49	31.8	91	M12 x 1.75	18	66.7	98	30
180	38	58	36.5	111.5	M16 x 2.0	24	79.4	112	36
280	38	70	36.5	96	M16 x 2.0	24	79.4	112	30
180DT	32	51	31.8	80	M12 x 1.75	22	66.7	102	23
280DT	38	59	36.5	83	M16 x 2.0	24	79.4	117	16
WHEN USING CONFLUENT BLOCK									
180DT	51	62	44.5	148	M20 x 2.5	30	96.8	124	26
280DT	51	72	44.5	180	M20 x 2.5	30	96.8	140	23

Suction Port

Size	A	B	C	D	E	F	G	H
63	38	12	35.7	71	M12 x 1.75	18	69.9	94
112	64	12	50.8	91	M12 x 1.75	18	88.9	113
180	76	15	61.9	108	M16 x 2.0	24	106.4	136
280	89	15.5	61.9	123	M16 x 2.0	24	120.7	152
180DT	102	15	77.8	152	M16 x 2.0	24	130.2	162
280DT	102	18	77.8	152	M16 x 2.0	24	130.2	170

Model K3VG	Page 33.34	Data Sheet P1001/07.99	
---------------	---------------	---------------------------	--

Unit Dimensions – Flange Accessory for Suction Port (SAE Code 61) (dimensions in mm)

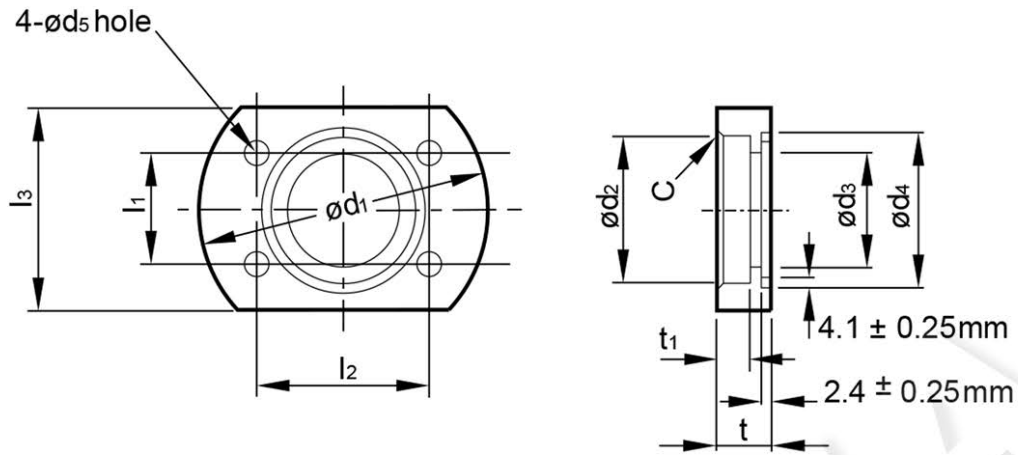

Pump size	l_1	l_2	l_3	t	t_1	d_1	d_2	d_3	d_4
63	35.7	69.9	80	20	10	110	49.1	38	55
112	50.8	88.9	105	25	15	130	77	64	80
180	62	106.4	125	30	20	160	90	76	90
280	69.9	120.7	135	30	-	170	90	90	105
180DT	77.8	130.2	145	30	20	190	115.4	100	120
280DT	77.8	130.2	145	30	20	190	115.4	100	120

Pump size	d_5	C	SAE Pipe Size	Screw Size
63	14	3	1 1/2	M12-35
112	14	3	2 1/2	M12-40
180	18	3	3	M16-50
280	18	4	3	M16-50
180DT	18	4	4	M16-50
280DT	18	4	4	M16-50

KAWASAKI PRECISION MACHINERY (UK) LTD
 Ernesettle, Plymouth, Devon, PL5 2SA, England
 Tel: +44 1752 364394 Fax: +44 1752 364816
 E Mail: info@kpm-uk.co.uk
 Web site: http://www.kpm-uk.co.uk

The specified data is for product description purposes only and may not be deemed to be guaranteed unless expressly confirmed in the contract

ALL RIGHTS RESERVED, SUBJECT TO REVISION

Model
K3VG

Page
34.34

Data Sheet
P1001/07.99

Issue 07/99