

Part number:

HYDROMA

HYDRAULICKÉ SYSTÉMY

**HIDROMA
SYSTEMS**

UKŁADY HYDRAULICZNE

HYDROMA

ГИДРАВЛИЧЕСКИЕ СИСТЕМЫ

ACCESSORI PER LANTERNA ACCESSORIES FOR BELLHOUSINGS

ANELLI AMMORTIZZANTI / DAMPING RINGS

tipo / series **A**

Costituiti da due anelli con interposta gomma vulcanizzata, vengono applicati tra lanterna e coperchio del serbatoio per smorzare le vibrazioni generate dalla trasmissione. Resistenti agli olii minerali possono lavorare fino ad una temperatura di + 80°C, riducendo la rumorosità del sistema di circa 3÷5 decibel.

These articles are made of two rings moulded into vulcanized rubber. Interposed between the bellhousing and the tank cover, they diminish the noise created by the power transmission by approx. 3÷5 dB. The employed rubber is mineral oil resistant, max. working temperature is 80°C.

Tabella / Table 22

Codice Part number	Dimensioni (mm) / Dimensions (mm)					
	A	B	C	D	E	F
A-200	146	200	165	15	43	M10
A-250	191	250	215	18	48	M12
A-300	238	300	265	18	53	M12
A-350	261	350	300	24	61,5	M16
A-400	311	400	350	24	69	M16

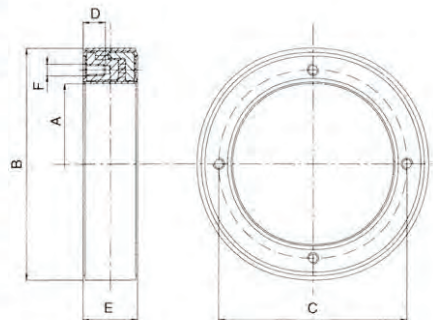

SUPPORTO MOTORE A PIEDINO / FOOT FLANGES

tipo / series **P**

Costruiti in lega di alluminio ad elevata resistenza meccanica vengono utilizzati quali supporti per lanterne con flangiatura normalizzata B5 sino ad un diametro esterno del motore di 350 mm. Da un Ø 400 est. del motore i piedini vengono costruiti in ferro.

Manufactured of high resistance aluminium alloy, these flanges are used to support our bellhousings with standard B5 flange up to an external diameter of the motor of Ø 350 mm. From Ø 400 upwards these foot flanges are made of steel.

Tabella / Table 23

Codice Part number	Dimensioni (mm) / Dimensions (mm)														
	A	B	C	D	E	F	G	I	N	O	P	Q	R	T	V
P160	165	135	80	100	45	10	45	98	80	111	130	10	9	35	9
P200	202	168	103	125	54	19	54	123	100	140	165	22	11,5	42,5	9
P250	252	220	130	155	105	25	25	150	125	180	215	25	13	92,5	11
P300	302	265	160	190	115	25	50	175	150	240	265	25	13	100	13
P350	362	310	250	286	183	30	73	205	175	256	300	30	18	165	15
P400	410	360	520	570	350	15	205	260	175	301	350	15	18	325	18
P450	460	400	590	640	390	15	235	295	200	351	400	15	18	365	18
P550	560	500	690	740	470	15	255	350	250	450	500	15	18	445	18

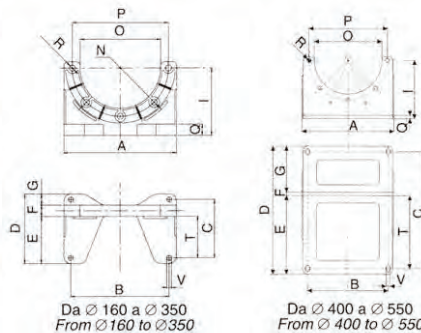

GUARNIZIONI / GASKETS

tipo / series **GL**

Guarnizioni in guarnital per lanterne. Tali guarnizioni vengono poste tra lanterne e serbatoi quale elemento di tenuta.

Gaskets for bellhousings, made of GUARNITAL.

They are interposed between bellhousing and the oil tank.

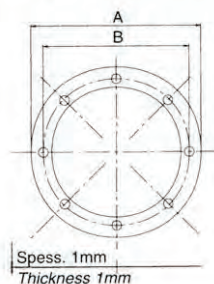

Codice Part number	Dimensioni (mm) Dimensions (mm)	
	A	B
GL 140	140	115
GL 160	160	130
GL 200	200	165
GL 250	250	215
GL 300	300	265
GL 350	350	300
GL 400	400	350

GUARNIZIONI / GASKETS

tipo / series **GP**

Guarnizioni in guarnital per pompe ad ingranaggi. Tali guarnizioni vengono poste tra pompa e lanterna quale elemento di tenuta.

Gaskets for gear pumps, made of GUARNITAL.

They are interposed between bellhousing and the pump.

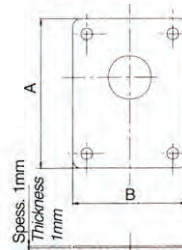

Codice Part number	Dimensioni (mm) Dimensions (mm)	
	A	B
GP 05	82	50
GP 1	90	69
GP 05-1M	90	69
GP 2	118	86
GP ZF	121	91
GP 3	170	120
GP 35	180	158
GP 4	230	175

ACCESSORI PER LANTERNA ACCESSORIES FOR BELLHOUSINGS

BARRE AMMORTIZZANTI PER PIEDINI / DAMPING RODS FOR OMT FOOT FLANGES

tipo / series **BMA - P****

Costruiti in lega di alluminio e costituiti da 2 barre tra le quali vi si interpone uno strato di gomma vulcanizzata antiolio; tale componente viene applicato tra piedino e coperchio del serbatoio, oppure tra il motore ed il suolo, dove vi sono le maggiori vibrazioni.

I pattini ammortizzanti possono lavorare fino ad una temperatura di +80°C, riducendo la rumorosità 3÷5 decibel.

In alu, they are made of two bars moulded into vulcanized rubber; they are used either between OMT foot flange and oiltank cover or between the motor and the ground where vibrations are higher.

They can work up to +80°C degrees and reduce the noise created by the power transmission by approx. 3÷5 Db.

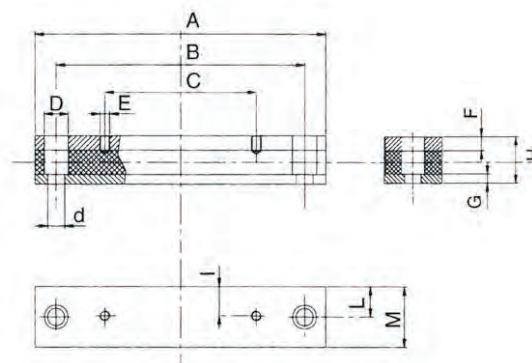

I codici presenti in tabella si riferiscono alla coppia di pattini / Indicated part-numbers refer to 2 pieces of damping rods

Codice / Part number (1 pair)	Dimensioni (mm) / Dimensions (mm)											
	A	B	C	D	d	E	F	G	H	I	L	M
BMA-P160-OMT	198	156	80	20	14	M8	12	8	40	21	26,5	53
BMA-P200-OMT	198	156	103	20	14	M8	12	8	40	24,5	26,5	53
BMA-P250-OMT	244	205	130	20	14	M10	12	8	40	24	26,5	53
BMA-P300-OMT	288	245	160	20	14	M12	12	8	40	20	26,5	53
BMA-P350-OMT	419	370	250	26	18	M14	15	15	60	28	36,5	73

BARRE AMMORTIZZANTI / DAMPING RODS

tipo / series **BMA**

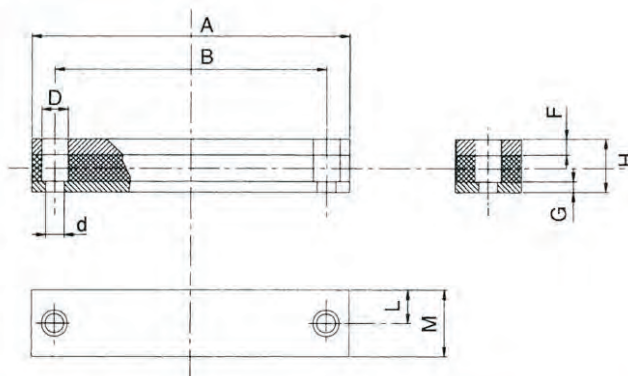

Codice / Part number (1 pair)	Tabella delle dimensioni (mm) / Dimensions (mm)										Taglie motori Motor size
	A	B	D	d	F	G	H	L	M		
BMA - 71	198	156	20	14	12	8	40	26,5	53	71;80;90	
BMA - 90	244	205	20	14	12	8	40	26,5	53	90L;100L;112L	
BMA - 132	288	245	20	14	12	8	45	26,5	53	132S;132M	
BMA - 160 M	343	300	26	18	15	15	60	36,5	73	160M	
BMA - 160 L	419	370	26	18	15	15	60	36,5	73	160L;180M	
BMA - 180	446	400	26	22	15	15	60	36,5	73	180	
BMA - 200	500	430	33	22	15	15	60	36,5	73	200L;225S	
BMA - 225	500	445	33	22	15	15	60	36,5	73	225M	
BMA - 250	500	445	33	22	15	15	60	51,5	103	250M	
BMA - 280	618	570	33	22	15	15	60	51,5	103	280M;280S	

ACCESSORI PER LANTERNA ACCESSORIES FOR BELLHOUSINGS

BARRE AMMORTIZZANTI / DAMPING RODS

tipo / series **BMA - F**

con forature motore
with borings for standard motors

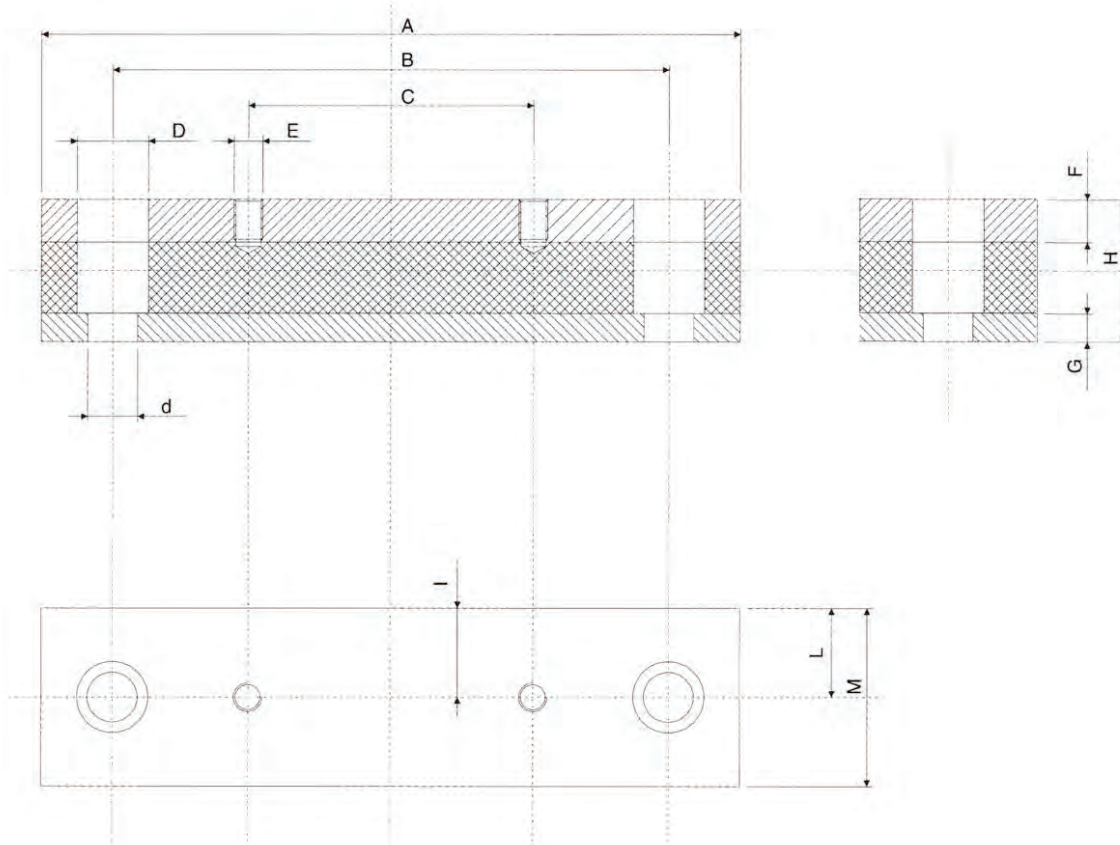

Codice Part number	Per motori taglia For motor size	Dimensioni (mm) / Dimensions (mm)											
		A	B	C	D	d	E	F	G	H	I	L	M
BMA - 71 - F	71	198	155	90	20	14	M6	12	8	40	21	26,5	53
BMA - 80 - F	80	198	155	100	20	14	M8	12	8	40	22	26,5	53
BMA - 90S - F	90S	198	155	100	20	14	M8	12	8	40	24,5	26,5	53
BMA - 90L - F	90L	244	205	125	20	14	M8	12	8	40	24	26,5	53
BMA - 100L - F	100L	244	205	140	20	14	M10	12	8	40	24	26,5	53
BMA - 112M - F	112M	244	205	140	20	14	M10	12	8	40	20	26,5	53
BMA - 132S - F	132S	288	245	140	20	14	M10	12	8	45	20	26,5	53
BMA - 132M - F	132M	288	245	178	20	14	M10	12	8	45	20	26,5	53
BMA - 160M - F	160M	343	300	210	26	18	M12	15	15	60	28	36,5	73
BMA - 160L - F	160L	419	370	254	26	18	M12	15	15	60	28	36,5	73
BMA - 180M - F	180M	419	370	241	26	18	M12	15	15	60	35	36,5	73
BMA - 180L - F	180L	446	400	279	26	22	M12	15	15	60	35	36,5	73
BMA - 200L - F	200L	500	430	305	33	22	M16	15	15	60	35	36,5	73
BMA - 225S - F	225S	500	430	286	33	22	M16	15	15	60	35	36,5	73
BMA - 225M - F	225M	500	445	311	33	22	M16	15	15	60	35	36,5	73
BMA - 250M - F	250M	500	445	349	33	22	M20	15	15	60	50	51,5	103
BMA - 280S - F	280S	618	570	368	33	22	M20	15	15	60	50	51,5	103
BMA - 280M - F	280M	618	570	419	33	22	M20	15	15	60	50	51,5	103