

Part number:

096-10136b

HYDROMA

HYDRAULICKÉ SYSTÉMY

**HIDROMA
SYSTEMS**

UKŁADY HYDRAULICZNE

HYDROMA

ГИДРАВЛИЧЕСКИЕ СИСТЕМЫ

DSP7

1 - IDENTIFICATION CODE FOR SOLENOID DISTRIBUTOR DSP7

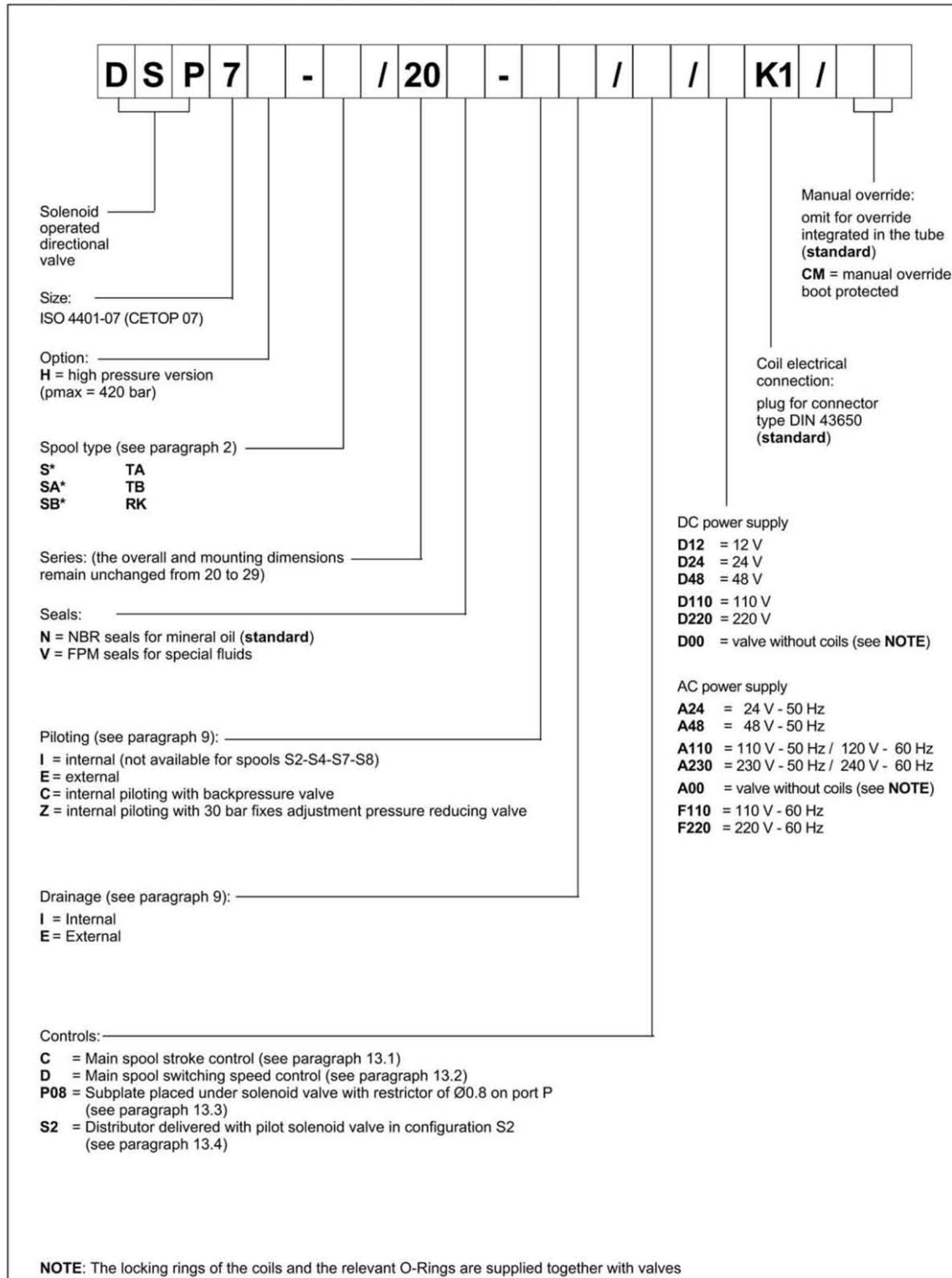

DSP7

2 - SPOOL TYPE

N.B.: Symbols refers to the DSP7 solenoid valve.

For the DSC7 hydraulic control version, please verify the connection scheme at paragraph 3.

Type S*:
2 solenoids - 3 positions
with spring centering

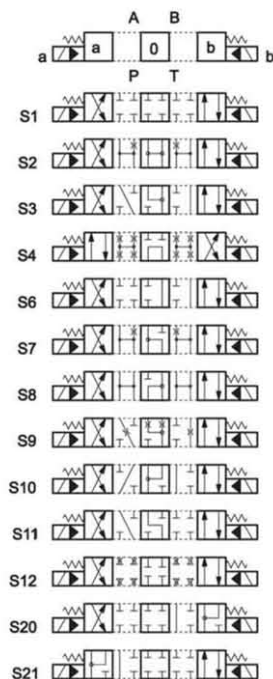

Type SA*:
1 solenoid side A
2 positions (central + external)
with spring centering

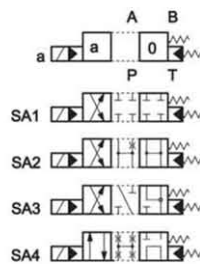

Type SB*:
1 solenoid side B
2 positions (central + external)
with spring centering

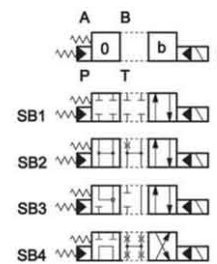

Type TA:
1 solenoid side A
2 external positions
with return spring

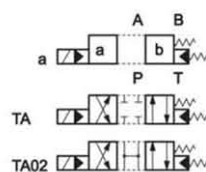

Type TB:
1 solenoid side B
2 external positions
with return spring

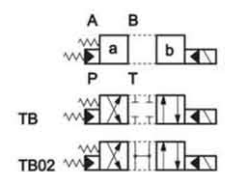

Type RK:
2 solenoids - 2 positions
with mechanical retention

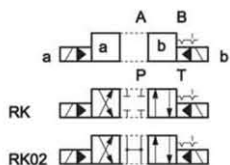

Type TA23 / TB23
three-way valve - 1 solenoid - 2 external positions, return spring

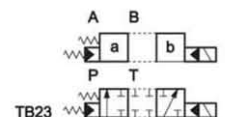
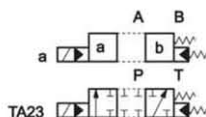

Besides the diagrams shown, which are the most frequently used, other special versions are available: consult our technical department for their identification, feasibility and operating limits.

Part number:

096-10136d

HYDROMA

HYDRAULICKÉ SYSTÉMY

**HIDROMA
SISTEMS**

UKŁADY HYDRAULICZNE

HYDROMA

ГИДРАВЛИЧЕСКИЕ СИСТЕМЫ

DSP7

3 - IDENTIFICATION CODE FOR HYDRAULIC DISTRIBUTOR DSC7

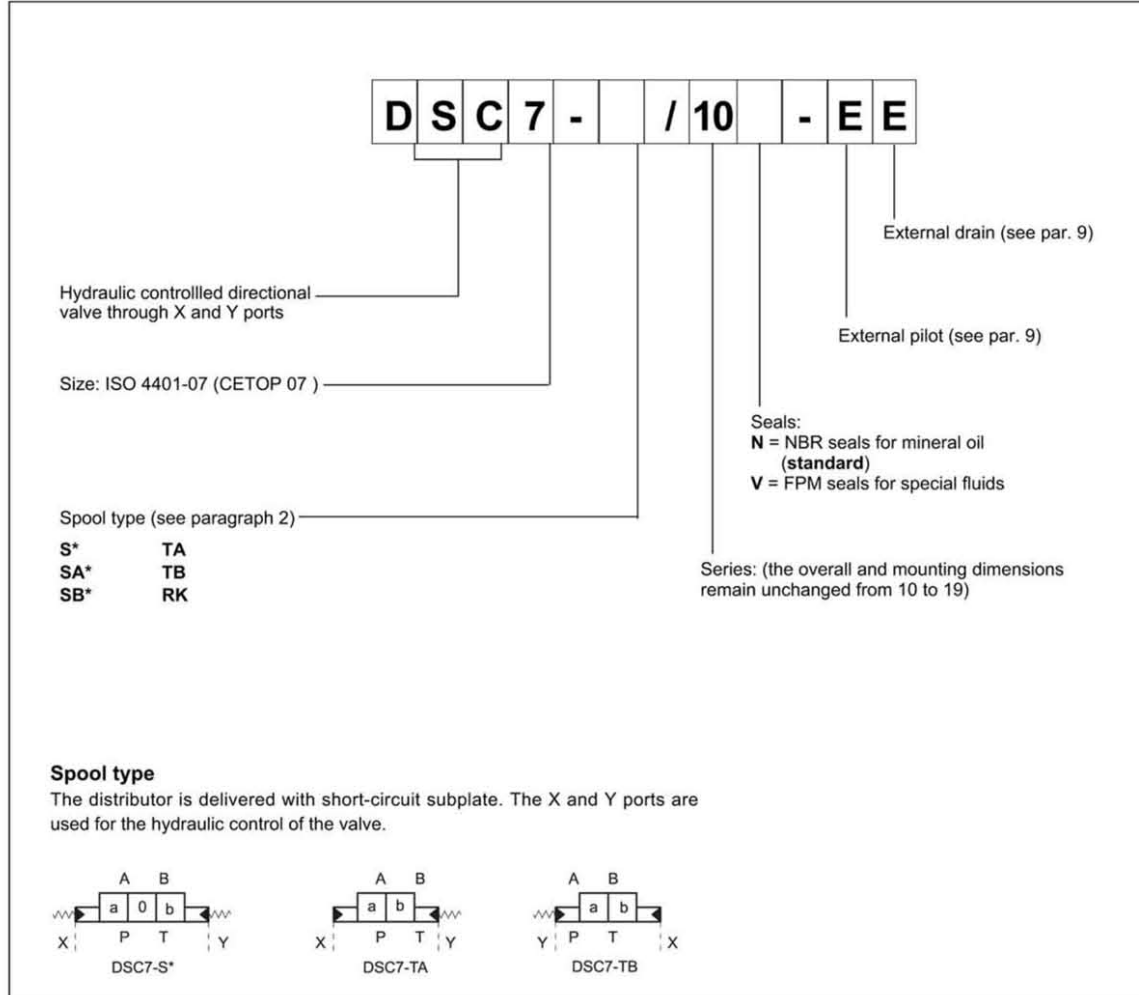

4 - HYDRAULIC FLUIDS

Use mineral oil-based hydraulic fluids HL or HM type, according to ISO 6743-4. For these fluids, use NBR seals (code N). For fluids HFDR type (phosphate esters) use FPM seals (code V). For the use of other kinds of fluid such as HFA, HFB, HFC, please consult our technical department. Using fluids at temperatures higher than 80 °C causes a faster degradation of the fluid and of the seals characteristics. The fluid must be preserved in its physical and chemical characteristics.

Part number:

096-10136e

HYDROMA

HYDRAULICKÉ SYSTÉMY

**HIDROMA
SYSTEMS**

UKŁADY HYDRAULICZNE

HYDROMA

ГИДРАВЛИЧЕСКИЕ СИСТЕМЫ

DSP7

5 - PRESSURE DROPS $\Delta p-Q$ (values obtained with viscosity 36 cSt at 50 °C)

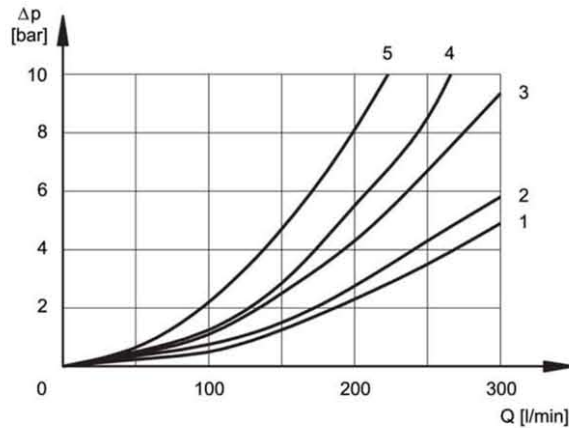

PRESSURE DROPS WITH VALVE ENERGIZED

SPOOL TYPE	FLOW DIRECTION			
	P-A	P-B	A-T	B-T
	CURVES ON GRAPH			
S1, SA1, SB1	1	1	3	4
S2, SA2, SB2	1	1	4	4
S3, SA3, SB3	1	1	4	4
S4, SA4, SB4	2	2	4	5
S6	1	1	3	4
S7	1	1	4	4
S8	1	1	3	4
S9	1	1	3	4
S10	1	1	3	4
S11	1	1	3	4
S12	1	1	3	4
S20	1	1	3	4
S21	1	1	4	4
TA, TB	1	1	3	4
TA02, TB 02	1	1	4	4
RK	1	1	3	4

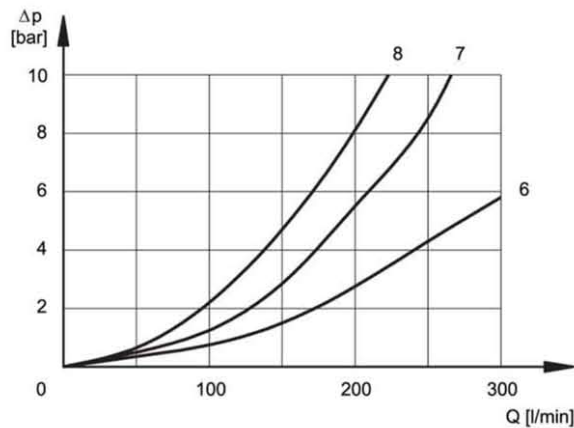

PRESSURE DROPS WITH VALVE IN DE-ENERGIZED POSITION

SPOOL TYPE	FLOW DIRECTION				
	P-A	P-B	A-T	B-T	P-T
	CURVES ON GRAPH				
S2, SA2, SB2					6
S3, SA3, SB3			7	7	
S4, SA4, SB4					7
S6				7	
S7					8
S8					8
S10			7	7	
S11			7		

6 - SWITCHING TIMES

The values indicated refer to a solenoid valve working with piloting pressure of 100 bar, with mineral oil at a temperature of 50 °C, at viscosity of 36 cSt and with PA and BT connections. The energizing and de-energizing times are obtained at the pressure variation which occurs on the lines.

TIMES ($\pm 10\%$) [ms]	ENERGIZED		DE-ENERGIZED	
	2 Pos.	3 Pos.	2 Pos.	3 Pos.
	AC solenoid	45	30	45
DC solenoid	75	60	60	45

Part number:

096-10136f

HYDROMA

HYDRAULICKÉ SYSTÉMY

**HIDROMA
SYSTEMS**

UKŁADY HYDRAULICZNE

HYDROMA

ГИДРАВЛИЧЕСКИЕ СИСТЕМЫ

DSP7

7 - OPERATING LIMITS

The curves define the flow rate operating fields according to the valve pressure for the different spool types.

The values have been obtained according to ISO 6403 norm with solenoids at rated temperature and supplied with voltage equal to 90% of the nominal voltage.

The values have been obtained with mineral oil, viscosity 36 cSt at 50 °C, and filtration ISO 4406:1999 classe 18/16/13..

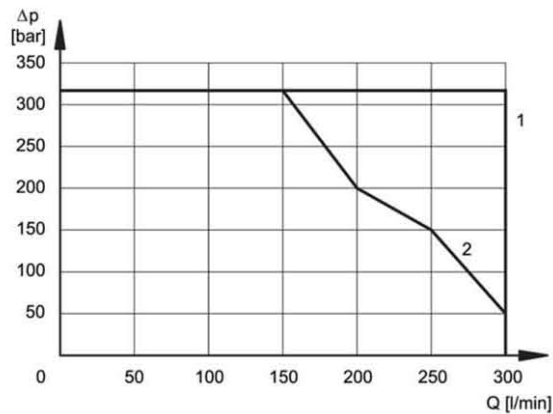

SPOOL TYPE	CURVE	
	P-A	P-B
S1, SA1, SB1	1	1
S2, SA2, SB2	1	1
S3, SA3, SB3	1	1
S4, SA4, SB4	2	2
S6	1	1
S7	2	2
S8	2	2

SPOOL TYPE	CURVE	
	P-A	P-B
S9	1	1
S10	1	1
S11	1	1
S12	1	1
S20	1	1
S21	1	1
TA, TB	1	1
TA02, TB02	1	1
TA23, TB23	1	1
RK	1	1

8 - PERFORMANCE CHARACTERISTICS

PRESSURES [bar]		
	MIN	MAX
Piloting pressure	12 (NOTE a)	280 (NOTE b)
Pressure on line T with internal drainage	-	140
Pressure on line T with external drainage	-	250

NOTES:

a) The minimum piloting pressure can be of 6 bar at low flows rates, but with higher flow rates a pressure of 12 bar is needed.

b) If the valve operates with higher pressures it is necessary to use the version with external pilot and reduced pressure. Otherwise, the valve with internal pilot and pressure reducing valve with 30 bar fixed adjustment can be ordered.

For DSP7H version the maximum piloting pressure is of 350 bar.

Part number:

096-10136g

HYDROMA

HYDRAULICKÉ SYSTÉMY

**HIDROMA
SISTEMS**

UKŁADY HYDRAULICZNE

HYDROMA

ГИДРАВЛИЧЕСКИЕ СИСТЕМЫ

DSP7

9 - PILOTING AND DRAINAGE

The DSP7 valves are available with piloting and drainage, both internal and external.

The version with external drainage allows for a higher back pressure on the outlet.

VALVE TYPE	Plug assembly	Plug assembly	
		X	Y
IE	INTERNAL PILOT AND EXTERNAL DRAINAGE	NO	YES
II	INTERNAL PILOT AND INTERNAL DRAINAGE	NO	NO
EE	EXTERNAL PILOT AND EXTERNAL DRAINAGE	YES	YES
EI	EXTERNAL PILOT AND INTERNAL DRAINAGE	YES	NO

9.1 - Backpressure valve incorporated on line P

Valves DSP are available upon request with backpressure valve incorporated on line P. This is necessary to obtain the piloting pressure when the control valve, in rest position, has the line P connected to the T port (spools S2, S4, S7, S8). The cracking pressure is of 5 bar with a minimum flow rate of 15 l/min.

Add **C** to the identification code for this request (see paragraph 1). **In the C version the piloting is always internal.**

The backpressure valve can be also delivered separately and it can be easily mounted on line P of the main control valve.

Specify the code **0266577** to order the backpressure valve.

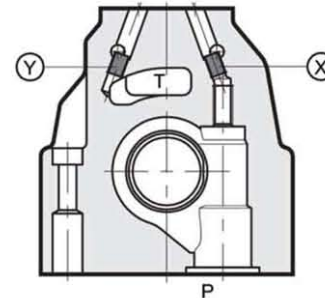

X: plug M6x8 for external pilot
Y: plug M6x8 for external drain

DSP7-C

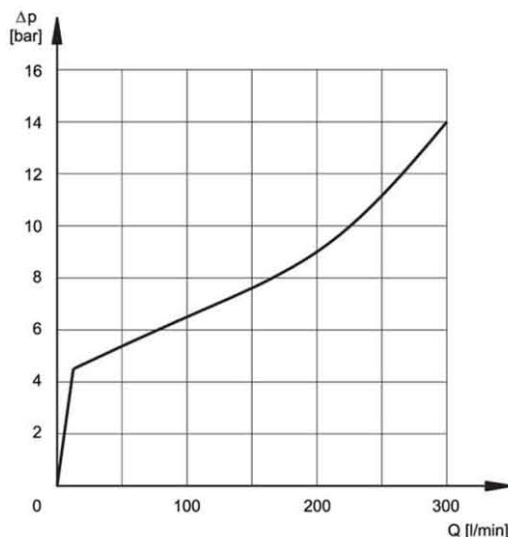
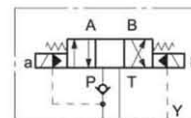

The curve refers to the pressure drop (body part only) with backpressure valve energized to which the pressure drop of the reference spool must be added. (see paragraph 5)

Version with back pressure valve

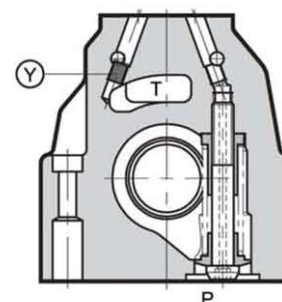

pilot always internal
Y: plug M6x8 for external drain

NOTE: the backpressure valve can't be used as check valve because it doesn't assure the seal.

Part number:

096-10136h**HYDROMA**

HYDRAULICKÉ SYSTÉMY

**HIDROMA
SYSTEMS**

UKŁADY HYDRAULICZNE

HYDROMA

ГИДРАВЛИЧЕСКИЕ СИСТЕМЫ

DSP7

10 - ELECTRICAL FEATURES

10.1 Solenoids

These are essentially made up of two parts: tube and coil. The tube is threaded into the valve body and includes the armature that moves immersed in oil, without wear. The inner part, in contact with the oil in the return line, ensures heat dissipation.

The coil is fastened to the tube by a threaded ring, and can be rotated 360°, to suit the available space.

NOTE 1: In order to further reduce the emissions, use of type H connectors is recommended. These prevent voltage peaks on opening of the coil supply electrical circuit (see CAT. 49 000).

NOTE 2: The IP65 protection degree is guaranteed only with the connector correctly connected and installed.

10.2 Current and absorbed power for DC solenoid valve

The table shows current and power consumption values relevant to the different coil types for DC.

The rectified current supply takes place by fitting the valve (with the exception of D12 coil) with an alternating current source (50 or 60 Hz), rectified by means of a bridge built-in to the "D" type connectors (see cat. 49 000), by considering a reduction of the operating limits by 5 + 10% approx.

Coils for direct current (values ± 5%)

Suffix	Nominal voltage [V]	Resistance at 20°C [ohm]	Current consumpt. [A]	Power consumpt. [W]	Coil code
D12	12	4,4	2,72	32,6	1902860
D24	24	18,6	1,29	31	1902861
D48	48	78,6	0,61	29,3	1902863
D110	110	423	0,26	28,6	1902864
D220	220	1692	0,13	28,6	1902865

10.3 Current and absorbed power for AC solenoid valve

The table shows current and power consumption values at inrush and at holding, relevant to the different coil types for AC current.

Coils for alternating current (values ± 5%)

Suffix	Nominal voltage [V]	Frequency [Hz]	Resistance at 20°C [ohm]	Current consumption at inrush [A]	Current consumption at holding [A]	Power consumption at inrush [VA]	Power consumption at holding [VA]	Coil code
A24	24	50	1,46	8	2	192	48	1902830
A48	48	50	5,84	4,4	1,1	204	51	1902831
A110	110V-50Hz	50/60	32	1,84	0,46	192	48	1902832
	120V-60Hz			1,56	0,39	188	47	
A230	230V-50Hz		140	0,76	0,19	176	44	1902833
	240V-60Hz			0,6	0,15	144	36	
F110	110	60	26	1,6	0,4	176	44	1902834
F220	220		106	0,8	0,2	180	45	1902835

Part number:

096-10136i

HYDROMA

HYDRAULICKÉ SYSTÉMY

**HIDROMA
SYSTEMS**

UKŁADY HYDRAULICZNE

HYDROMA

ГИДРАВЛИЧЕСКИЕ СИСТЕМЫ

DSP7

11 - OVERALL AND MOUNTING DIMENSIONS FOR SOLENOID DISTRIBUTOR DSP7

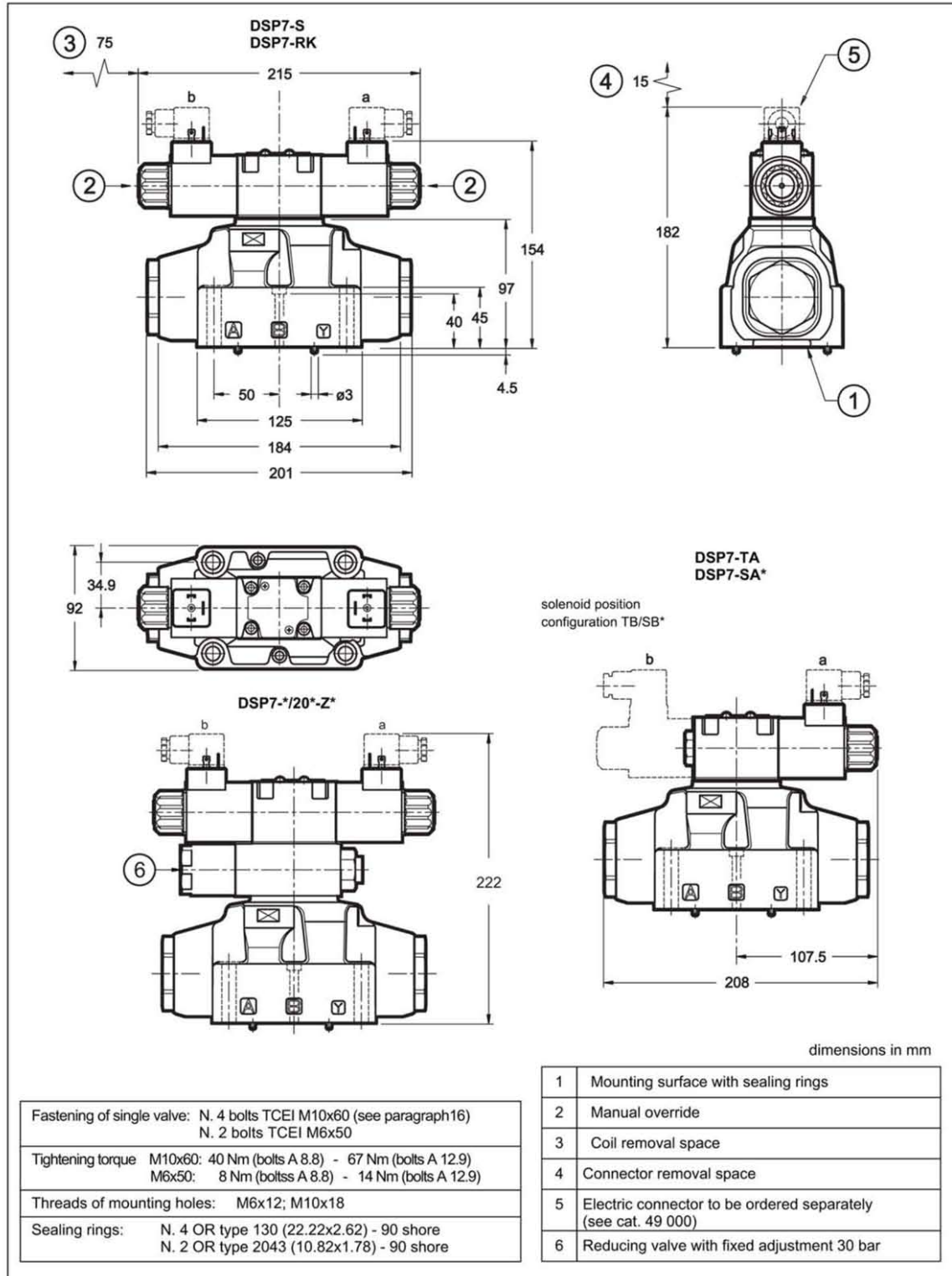

Part number:

096-10136j

HYDROMA

HYDRAULICKÉ SYSTÉMY

**HIDROMA
SYSTEMS**

UKŁADY HYDRAULICZNE

HYDROMA

ГИДРАВЛИЧЕСКИЕ СИСТЕМЫ

DSP7

12 - OVERALL AND MOUNTING DIMENSIONS FOR HYDRAULIC DISTRIBUTOR DSC7

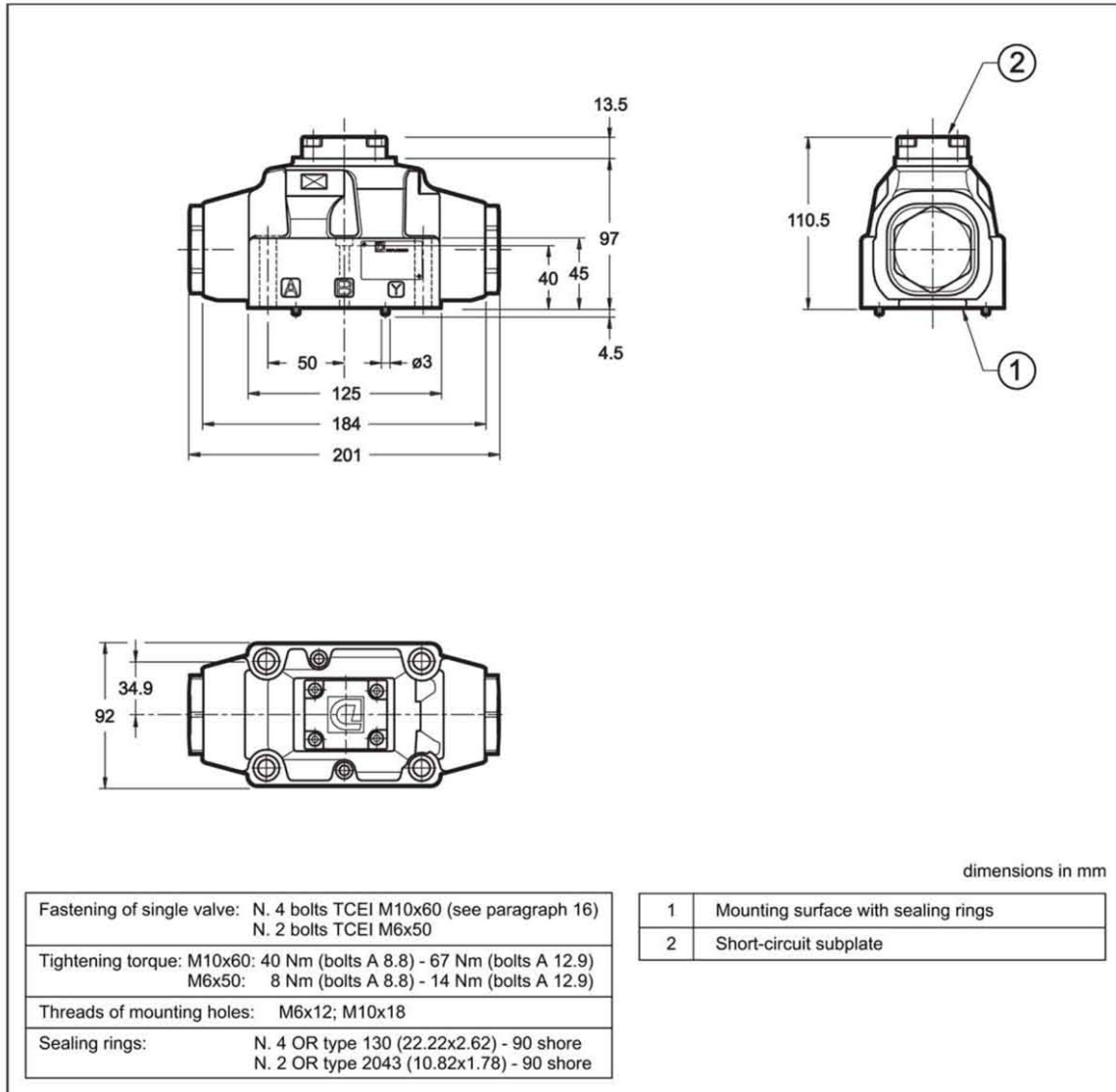

Part number:

096-10136k

HYDROMA

HYDRAULICKÉ SYSTÉMY

**HIDROMA
SYSTEMS**

UKŁADY HYDRAULICZNE

HYDROMA

ГИДРАВЛИЧЕСКИЕ СИСТЕМЫ

DSP7

13 - OPTIONS

13.1 Control of the main spool stroke: C

With the help of special side plugs, it is possible to introduce stroke controls in the heads of the piloted valve so as to vary the maximum spool clearance opening.

This solution allows control of the flow rate from the pump to the actuator and from the actuator to the outlet, obtaining a double adjustable control on the actuator.

Add the letter **C** to the identification code to request this device (see paragraph 1).

DSP7-S*/C

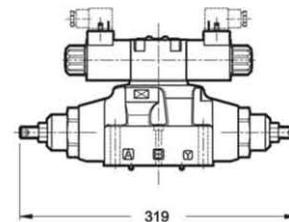

13.2 Control of the main spool shifting speed: D

By placing a MERS type double flow control valve between the pilot solenoid valve and the main distributor, the piloted flow rate can be controlled and therefore the changeover smoothness can be varied.

Add the letter **D** to the identification code to request this device (see paragraph 1).

DSP7-S*/D

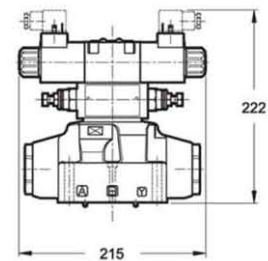

13.3 Subplate with throttle on line P

It is possible to introduce a subplate with a restrictor of $\varnothing 0,8$ on line P between the pilot solenoid valve and the main distributor.

Add **P08** to the identification code to request this option (see paragraph 1).

DSP7-S*/P08

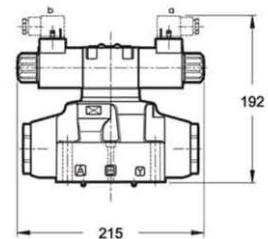

13.4 Solenoid operated distributor with pilot valve in configuration S2

It is possible to deliver the solenoid operated distributor with pilot valve in configuration S2 (all the ports at outlet). With this option the piloting is necessarily external.

Add **S2** to the identification code to request this option (see paragraph 1).

This configuration is used with external piloting in order to allow the unloading of the piloting line when the solenoid operated valve is in rest position.

14 - MANUAL OVERRIDE, BOOT PROTECTED: CM

Whenever the solenoid valve installation may involve exposure to atmospheric agents or use in tropical climates, the manual override, boot protection is recommended.

Add the suffix **CM** to request this device (see paragraph 1). For overall dimensions see cat. 41 150.

Part number:

096-101361

HYDROMA

HYDRAULICKÉ SYSTÉMY

**HIDROMA
SYSTEMS**

UKŁADY HYDRAULICZNE

HYDROMA

ГИДРАВЛИЧЕСКИЕ СИСТЕМЫ

DSP7

15 - ELECTRIC CONNECTORS

The solenoid operated valves are delivered without the connectors. They must be ordered separately.

For the identification of the connector type to be ordered, please see catalogue 49 000.

16 - INSTALLATION

Configurations with centering and recall springs can be mounted in any position; type RK valves - without springs and with mechanical detent - must be mounted with the longitudinal axis horizontal. Valve fastening takes place by means of screws or tie rods, laying the valve on a lapped surface, with values of planarity and smoothness that are equal to or better than those indicated in the drawing. If the minimum values of planarity or smoothness are not met, fluid leakages between valve and mounting surface can easily occur.

NOTE: Use of class 12.9 fastening screws is recommended for valves DSP7H (high pressure version)

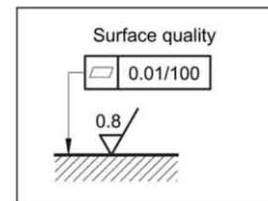

17 - SUBPLATES (see catalogue 51 000)

Type with rear ports	PME07-AI6G
Type with side ports	PME07-AL6G
P, T, A, B, port dimensions	1" BSP
X, Y port dimensions	1/4" BSP