

Part number:

HYDROMA

HYDRAULICKÉ SYSTÉMY

**HIDROMA
SISTEMS**

UKŁADY HYDRAULICZNE

HYDROMA

ГИДРАВЛИЧЕСКИЕ СИСТЕМЫ



EDC-1

DIGITAL ELECTRONIC CONTROL UNIT FOR OPEN-LOOP SINGLE SOLENOID PROPORTIONAL VALVES SERIES 10

PLUG VERSION

OPERATING PRINCIPLE

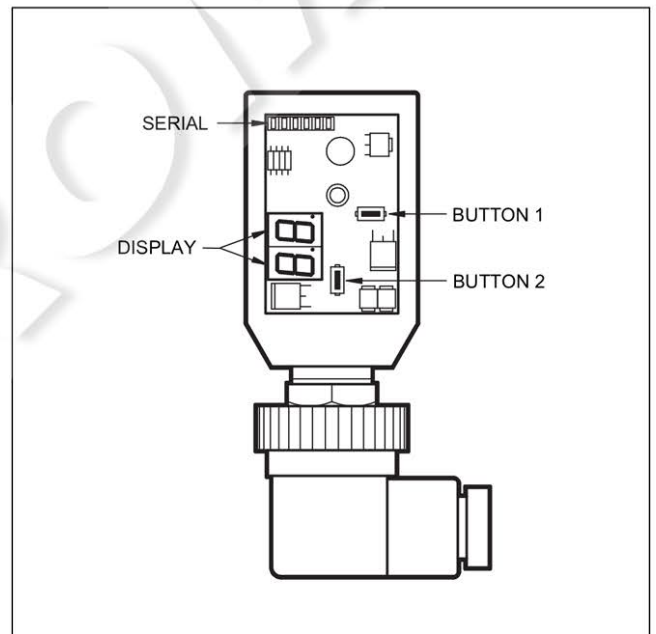
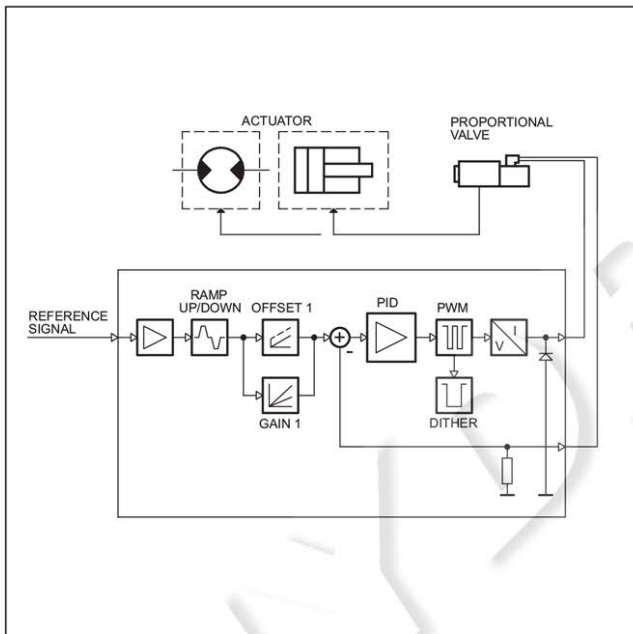

TECHNICAL CHARACTERISTICS

Power supply	V DC	10 ÷ 30 - ripple included
Required power	W	min 20 - max 40 (see paragraph 2.1)
Output current	mA	min 800 - max 2600 (see paragraph 1)
Power supply electrical protections		overload over 33V polarity inversion
Output electrical protections		short-circuit
Analogue electrical protections		up to 30 V DC
Available reference signals (selectable from the jumper)	0 ÷ 10V 0 ÷ 5V 4 ÷ 20 mA	input impedance 100 kΩ input impedance 100 kΩ input impedance max 500 Ω
Connector type		DIN 43650
Electromagnetic compatibility (EMC): - EMISSIONS CEI EN 61000-6-4 - IMMUNITY CEI EN 61000-6-2		according to 2004/108/CEE standards (see paragraph 5 - NOTE 1)
Protection to atmospheric agents (CEI EN 60529)		IP 65 - 67
Operating temperature range	°C	-20 / +70
Mass	kg	0,10

1 - IDENTIFICATION CODE

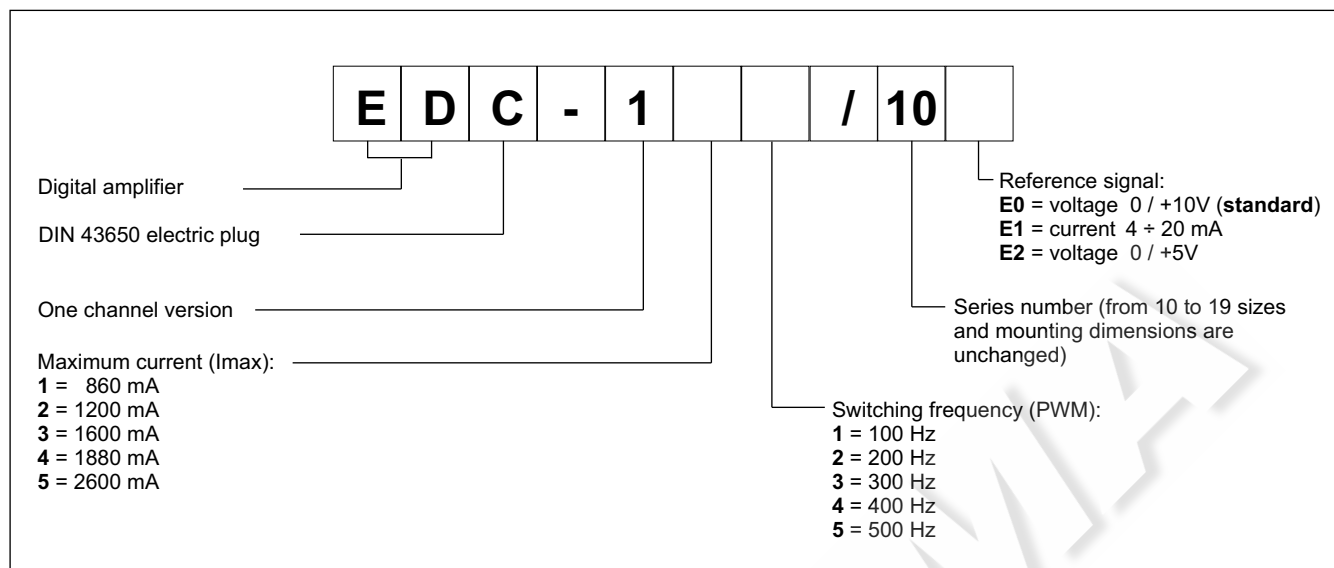

The EDC-1 connector is a digital amplifier controlling open loop proportional valves. The unit supplies a variable current proportionally to the reference signal and independently of temperature variations or load impedance, with a resolution of 1% on 2600 mA (the full scale value).

The PWM stage on the solenoid power supply makes it possible to reduce the valve hysteresis thus optimising control precision. The connector is customizable with different maximum current sizes and switching frequencies (PWM), optimized according to the valve to be controlled.

Setting is possible by buttons and display inside the case, or with a notebook by RS232 with the software EDC-PC, (see par. 6.2)

2 - FUNCTIONAL SPECIFICATIONS

Electric power supply

The connector requires a power supply of 10 ± 30 V DC (terminals 1 and 2).

NOTE: The value of the power supply voltage on the connector must be higher than the rated working voltage of the solenoid to be controlled.

The power supply voltage must be rectified and filtered, with maximum admissible ripple within the above voltage range.

The power required by the connector depends on the power supply voltage and on the maximum value of the supplied current (it is determined by the card version). In general a conservative value of the required power can be considered as the product of $V \times I$.

Example: a connector with a maximum current = 800 mA and a power supply voltage of 24 V DC requires a power of about 20W. In case of a card with a maximum current = 1600 mA and a power supply voltage of 24 V DC the used power is equal to 38.5 W.

2.2 - Electrical protection

The connector is protected against overvoltage and polarity inversion.

On the output a protection against any short circuit is foreseen.

2.3 - Reference signal

The connector accepts voltage reference signals with 0 ± 10 V and 0 ± 5 V, in 4 ± 20 mA current, from an external generator (PLC, CNC) or external potentiometer.

See paragraph 7 for electric connections referring to the different connector versions.

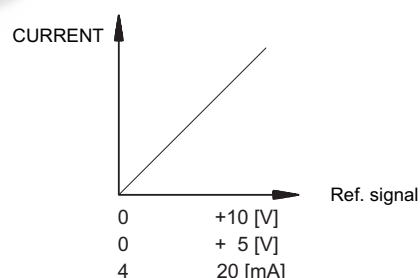

3 - SIGNALS

3.1 - POWER ON (Power supply)

Display indicate the connector is ON and with +24V DC.

4 - ADJUSTMENTS

There are two way adjustments: variables view and parameters editing. The first one enables the real time monitoring of the control values, for both required and read current, on both channels. The second modality enables the operating parameters view and editing.

4.1 - Variables view

The card is switched on at the variables view modality, and it shows the first variable value, that is the U1 parameter (reference signal). Pushing button (1) the current to solenoid is displayed. By means of (1) key, the different variables can be selected. Each time a variable is selected, its short name appears for approximately one second. By briefly pressing the keys, the current variable name appears for approximately one second.

The variables that can be selected are:

- U1:** Reference signal:
 0 + 10V
 0 + 5V
 4 + 20mA (displayed as 2 + 10)
- C1:** current required according to the applied reference signal, expressed in ampere, ranging between 0 and 2.6 A

All the mentioned parameters can be viewed on the two digits display, located on the connector front panel.

The selected value has to be read as follows (example for EDC-15*/10E* card):

REFERENCE		DISPLAY U1		DISPLAY C1
(V)	(mA)	(V)	(V)	(Ampere)
0	4	0.0	2.0	40 (mA)
5	12	5.0	6.0	13 (A)
10	20	10.	10.	26 (A)

4.2 - PARAMETERS EDITING

To access the parameter editing, press the key (2) for at least 3 seconds.

The first parameter displayed is G1. To modify it, press the key (1) for two seconds, until the display starts blinking. Use the key (2) to increase the value and the key (1) to decrease it. To save the new value, press both the keys. The display stops blinking.

Pressing the key (2) again is possible to scroll all the parameters. To modify some parameters, repeat the steps above-mentioned for the G1 parameter.

The parameters that can be selected are:

- G1:** "I Max" current, expressed in milliampere.
 It sets the maximum current to the solenoid, when the reference signal is at the maximum value of +10 V (or 20 mA). It is used to limit the maximum value of the hydraulic size controlled by the valve.
 Default value = I_{max}
 Range = 50 + 100% of I_{max}
- o1:** "I Min" current, expressed in milliampere.
 It sets the offset current to the solenoid, when the reference signal exceeds the limit of 0,1 V (or 0,1 mA). It is used to null the insensitiveness area of the valve (dead band).
 Default value = 0%
 Range = 0 + 50% of I_{max}
- u1:** "Ramp Up" increasing ramp time, expressed in seconds.
 It sets the current increasing time, for a variation from 0 to 100% of the input reference.
 It is used to slow down the valve response time in the case of a sudden variation of the reference signal.
 Default value = 00 sec.
 Range = 00 + 50 sec.

- d1:** "Ramp Dn" decreasing ramp time, expressed in seconds.
 It sets the current decreasing time, for a variation from 100% to 0 of the input reference. It is used to slow down the valve response time in the case of a sudden variation of the reference signal.
 Default value = 00 sec.
 Range = 00+ 50 sec.
- Fr:** PWM frequency, in Hertz.
 It sets the PWM frequency, which is the pulsating frequency of the control current. The PWM decrease improves the valve accuracy, decreasing the regulation stability. The PWM increase improves the regulation stability, causing a higher hysteresis.
 Default value = PWM (according to version card)
 Range = 50 + 500Hz

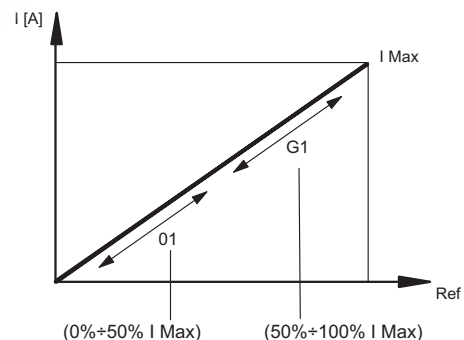
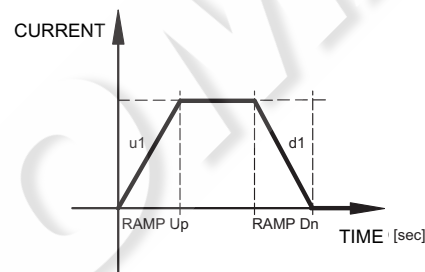

4.3 - ERROR SIGNAL

- EE:** breakdown cable error on 4 + 20 mA signal (threshold 3 mA).
 Reset the alarm turning off the +24 V DC cable.

5 - INSTALLATION

The connector type electronic unit is suitable for direct assembly on the solenoid of the relative proportional valve. The 4-core connection cable (0,5 mm² individual wire section) is supplied pre-wired and in a standard length of 2.5 m (DIN 47100 standard).

NOTE 1

To observe EMC requirements it's important that the control unit electrical connection is in compliance with the wiring diagram of chapter 7. As a general rule, the valve and the electronic unit connection wires must be kept as far as possible from interference sources (e.g. power wires, electrical motors, inverters and electrical switches).

In environments where there are critical electromagnetic interferences, a complete protection of the connection wires can be requested.

7 - WIRING DIAGRAM

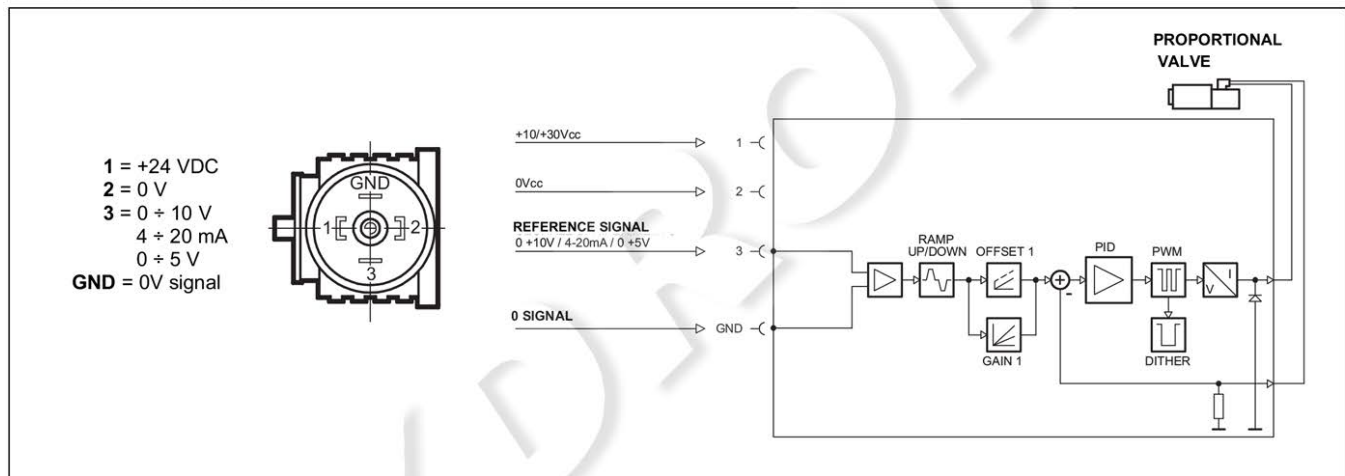

8 - OVERALL AND MOUNTING DIMENSIONS

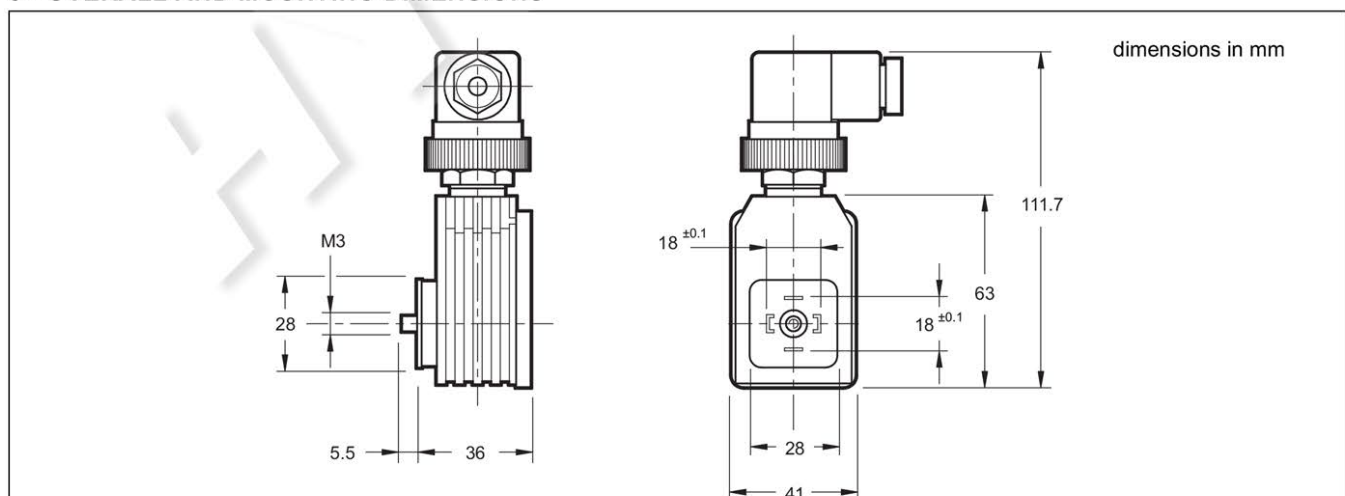

6 - START UP, CONTROL SETTINGS AND SIGNAL MEASUREMENT

6.1 - Set up

Settings can be changed by either acting on the (1) and (2) keys located on the card front panel, or using the EDC-PC hardware and software kit.

6.2 - EDC-PC Software

The relevant hardware and software kit (to be ordered separately) allows to read the values and to set the connector easily.

The software communicates, through a flat cable, to the relevant connector placed in the EDC-1 panel, behind the protecting gate. The EDC-PC software compatibility is guaranteed only on Windows 2000 and Windows XP operating systems.