

Part number:

**HYDROMA**

HYDRAULICKÉ SYSTÉMY

**HIDROMA  
SYSTEMS**

UKŁADY HYDRAULICZNE

**HYDROMA**

ГИДРАВЛИЧЕСКИЕ СИСТЕМЫ

## Direct electrical control classification

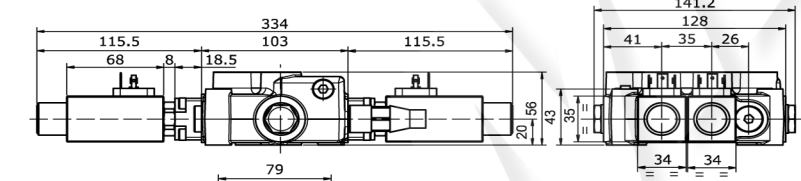
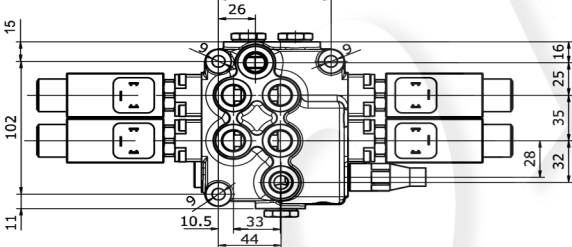
code	description	dimensions
<b>H036</b> leave out the spool return action code	Direct electric control 12 Vdc (45W - 3,75 A)	
<b>H037</b> leave out the spool return action code	Direct electric control 24 Vdc (45W - 1,88 A)	

type	M45	
Rated voltage	12 VDC	24 VDC
Rated current	3,75 A	1,88 A
Rated power	45 W	
Permitted working voltage	±10% Nominal	
Max ambient temperature	+40°C	
Max oil temperature	+80°C	
Operation time	S1 (100%)	
Protection degree	IP65	
Insulation degree	H	
Standard connector	DIN 43650	
Spool stroke	2,5 + 2,5 mm	

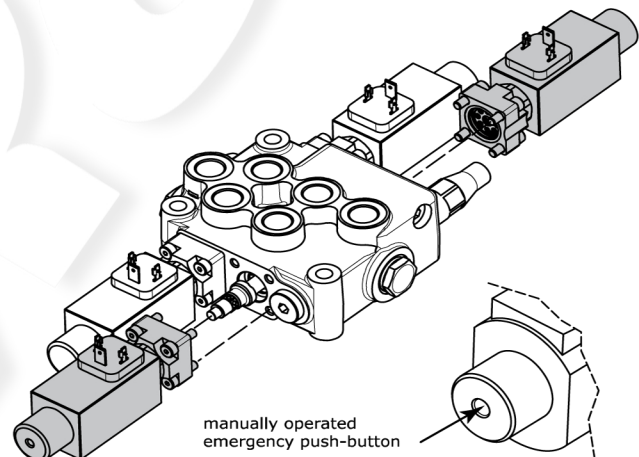

The H036 and H037 direct electric controls come as two kits each including a: spring, solenoid and adapter. The Direct electric controls use a type E special spool and a type special body. The ON-OFF Electric Control kit includes a manually operated emergency push-button.

## Operating limit curve

Data detected after voltage decrease equal to 28% of the rated value (conditions occurring with coil under stabilization temperature conditions with rated voltage reduced by 10%).

