

Part number:

HYDROMA

HYDRAULICKÉ SYSTÉMY

**HIDROMA
SYSTEMS**

UKŁADY HYDRAULICZNE

HYDROMA

ГИДРАВЛИЧЕСКИЕ СИСТЕМЫ

"FULCRO"

**POMPE A MANO
CON INVERTITORE DI FLUSSO
HAND PUMPS
WITH DIRECTIONAL CONTROL VALVE**

**CODICE FAMIGLIA
FAMILY CODE**

106

**SERIE
SERIES**

**PMI
12-25-45**

Pompe a mano con azionamento a doppio effetto (la pompa eroga olio sia spingendo che tirando la leva) per impianti a doppio effetto, direttamente flangiabili su serbatoio e con rubinetto di scarico a tenuta conica incorporato.

Sono disponibili in tre diverse cilindrate per consentire le più svariate applicazioni e per limitare lo sforzo sulla leva in ogni situazione. Hanno il corpo in ghisa con trattamento di zincatura+sigillatura e lo stelo nichelato.

Double acting hand pumps (the pump delivers oil both pushing and pulling the lever) suitable to operate double acting applications. They can be fitted also onto tank and are equipped with tapered lowering valve.

These hand pumps can have 3 different sizes to perform various applications and to achieve smoother loads on the lever. They are available with nodular cast-iron body zinc plating+sealed and nickel-plated spool.

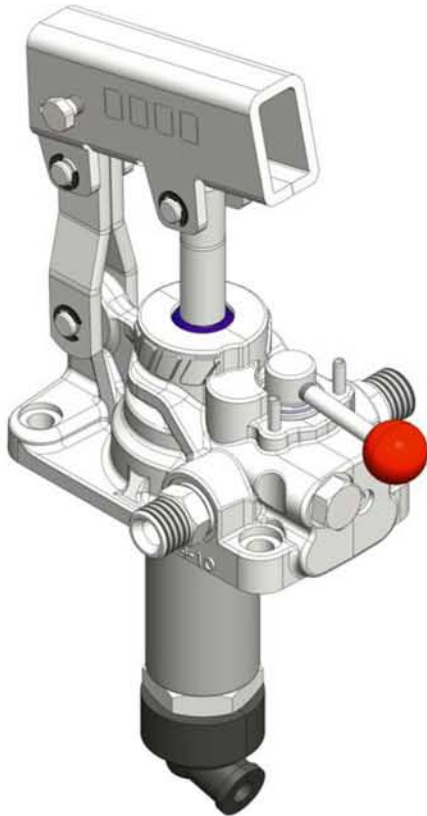

Codice fascicolo: 997-400-10610

Data: Venerdì 3 novembre 2017

Codice foglio: 997-106-00710 Rev: AP

**Codice di ordinazione (senza leva)
Order code (without lever)**

		FULCRO 12	FULCRO 25	FULCRO 45
Senza Serbatoio Without Tank		106-017-00015	106-007-00017	106-007-00026
	Con serbatoi With Tank Litri / Litres			
Plastica / Plastic	1	106-016-00016	106-005-00019	106-006-00063
	2	106-016-00025	106-005-00028	106-006-00054
	3	106-016-00034	106-005-00037	106-006-00018
	4	106-016-00038	106-005-00041	106-006-00072
	5	106-016-00043	106-005-00046	106-006-00027
	7	106-016-00052	106-005-00055	106-006-00036
	10	106-016-00061	106-005-00064	106-006-00045

Ingombro
Overall Dimension

	A	A1	B	D1	D2	E
	mm	mm	mm	°	°	mm
FULCRO 12	143	187	120	18,5	45	35
FULCRO 25	142	193	127	20	45	35
FULCRO 45	141	193	138	20	45	42

Schema Idraulico / Hydraulic layout

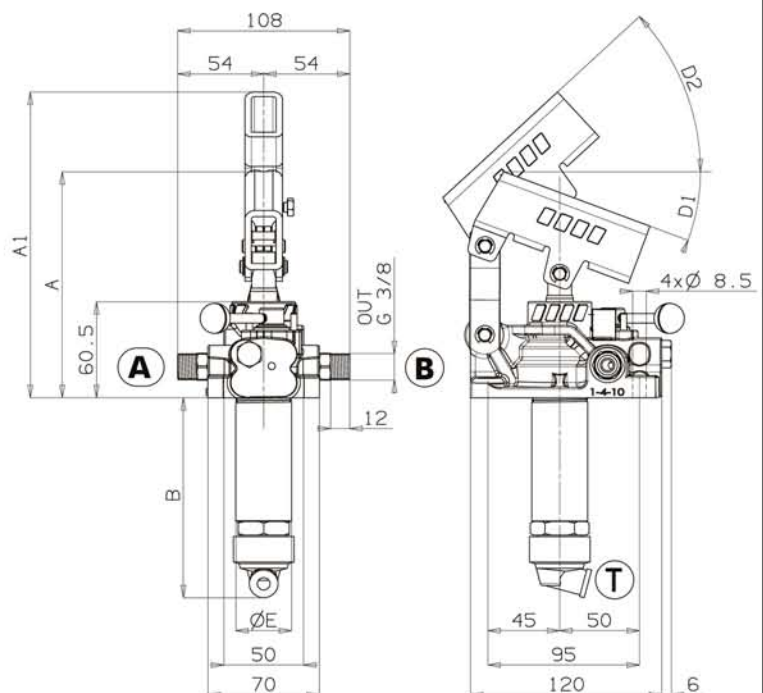
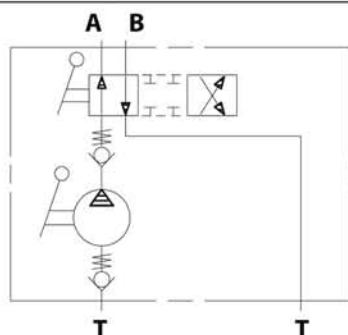

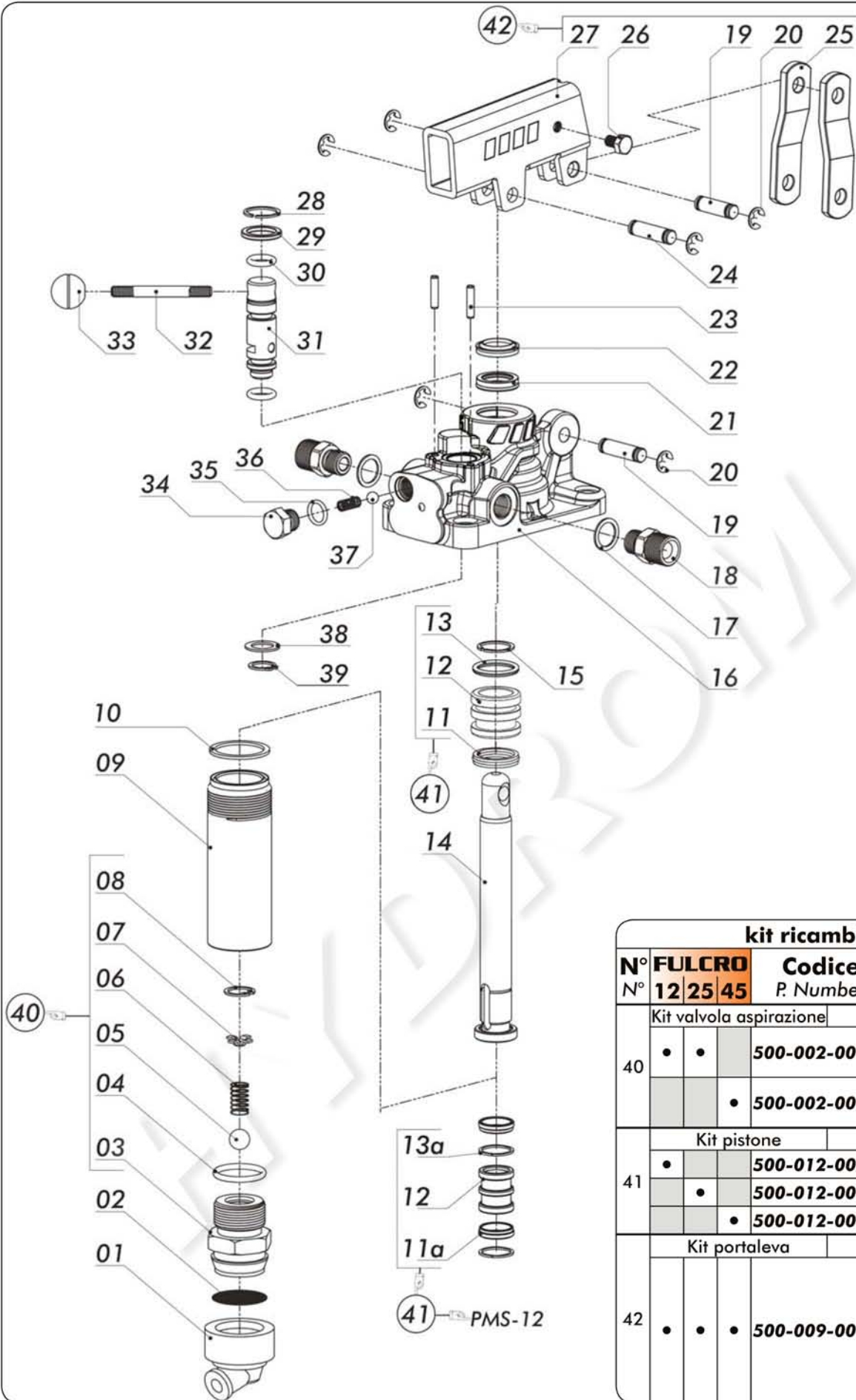

kit ricambi / kit's			
N°	FULCRO	Codice	Gruppo
N°	12 25 45	P. Number	Assembly
40		Kit valvola aspirazione	Suction valve kit
•	•	500-002-00016	
		• 500-002-00025	
41		Kit pistone	Piston assembly
•		500-012-00032	
	•	500-012-00014	
		• 500-012-00023	
42		Kit portaleva	Hand lever holder kit
•	•	• 500-009-00135	

Codice fascicolo: 997-400-10610

Data: Venerdì 3 novembre 2017

Codice foglio: 997-106-00710 Rev: AP

N°	FULCRO			Codice P. Number	Descrizione Description	Q.
	12	25	45			
1	•	•	•	506-000-00392	Guarnizione portafiltro Suction cap	1
2	•	•	•	550-001-00012	Filtro acciaio rotondo Steel strainer	1
3	•	•		540-005-00019	Corpo valvola di aspirazione Suction valve casing	1
			•	540-005-00037		
4	•	•		506-002-00201	Guarnizione OR O-ring	1
			•	506-003-00095		
5	•	•	•	510-009-00116	Sfera tenuta Ball	1
6	•	•	•	512-005-00689	Molla valvola di aspirazione Spring for suction valve	1
7	•	•	•	550-001-00101	Guidamolla Spring-guide	1
8	•	•	•	501-001-00113	Anello elastico Circlip	1
9	•			537-002-00037	Cilindro acciaio Steel stem	1
		•		537-002-00019		
			•	537-002-00028		
10	•	•		116-009-01255	Rondella tenuta cilindro Washer	1
			•	116-009-01308		
11a	•			506-000-00516	Guarnizione speciale Special gasket	2
11		•		506-000-00258	Guarnizione speciale Special gasket	1
			•	506-000-00267		
12	•			532-002-00082	Pistone Piston	1
		•		532-002-00028		
			•	532-002-00037		
13a	•			550-004-00046	Anello antiestrusore Locking ring	2
13		•		506-002-00158	Guarnizione OR O-ring	1
			•	506-002-00229		
14	•			535-001-00121	Stelo Piston rod	1
		•		535-001-00069		
			•	535-001-00078		
15	•			501-011-00086	Anello elastico Circlip	1
		•		501-011-00111		
			•	501-011-00148		
16	•			517-001-00496	Corpo pompa a mano Hand pump housing	1
		•		517-001-00512		
			•	517-001-00530		
17	•	•	•	116-009-00158	Rondella utilizzi Washer	2
18	•	•	•	116-006-00259	Nipplo utilizzi Pressure nipple	2
19	•	•	•	526-001-00095	Spinotto lunghezza 26mm Gudgeon Pin 26mm	2
20	•	•	•	501-015-00028	Anello elastico Circlip	6
21	•			506-000-01926	Guarnizione a labbro Lip seal	1
		•		506-000-01935		
			•	506-000-01944		
22	•			506-000-02729	Guarnizione raschiapolvere Wiper seal	1
		•		506-000-02701		
			•	506-000-02738		
23	•	•	•	501-004-00058	Spina elastica Spring pins	2
24	•	•	•	526-001-00086	Spinotto Gudgeon Pin	1
25	•	•	•	538-001-00081	Biella Brackets	2
26	•	•	•	502-002-00012	Vite blocco leva Locking lever screw	1
27	•	•	•	539-001-00212	Portaleva Lever holder	1
28	•	•	•	501-011-00102	Anello elastico Circlip	1
29	•	•	•	506-000-00963	Guarnizione protezione stelo Seal	1
30	•	•	•	506-002-00041	Guarnizione OR O-ring	1
31	•	•	•	536-001-00030	Stelo invertitore Diverter rod	1
32	•	•	•	539-004-00031	Leva per invertitore Directional control lever	1
33	•	•	•	509-001-00073	Pomello rosso Red knob	1
34	•	•	•	540-003-00360	Tappo valvola di ritegno Non-return valve cover	1
35	•	•	•	506-019-10200	Guarnizione OR O-ring	1
36	•	•	•	512-005-00312	Molla valvola di ritegno Non-return valve spring	1
37	•	•	•	510-009-00054	Sfera tenuta di ritegno Non-return ball	3
38	•	•	•	530-001-00489	Distanziale Spacer	1
39	•	•	•	501-002-00103	Anello elastico Circlip	1

Dati Tecnici
Technical data

Tipo pompa Pump type	Pressione massima Max. Pressure	Cilindrata Displacement			Peso Weight
		Completa / Full cm ³ /ciclo	Tiro / Pull cm ³ /ciclo	Spinta / Push cm ³ /ciclo	
	bar				Kg
FULCRO 12	350	12	6,1	5,9	2,9
FULCRO 25	300	25	13,4	11,6	2,8
FULCRO 45	270	45	23,7	21,3	3,2

Fluido idraulico Fluid	Minerale o sintetico compatibile con guarnizioni: Mineral or synthetic compatible with the following seals: NBR, FKM, FPM, Nylon				
Viscosità cinematica consigliata Kinematic viscosity suggested	T media ambiente (°C) Average ambient temp. (°C)	< -10	-10÷10	10÷35	> 35
	VG (cSt = mm ² /s)	22	32	46	68
Temperatura di utilizzo Working temperature		-15° +110°C			

Kit di guarnizioni
Seal kit

FULCRO 12	FULCRO 25	FULCRO 45
106-900-00551	106-900-00604	106-900-00659



106-000-00032 PIA.APP.GRP.PMP. PMS-PMI
 MOUNTING PLATE FOR TANK PMS-PMI



106-000-00078 AST. CON IMP.PMS/PMI L.600 MM 35x15
 LEVER FOR PMS/PMI L. 600 MM 35x15



106-960-00700 KIT MONTAGGIO POMPE PMS/PMI
 MOUNTING KIT FOR PUMPS PMS/PMI

Sforzo in fase di pompaggio con leva standard
Load while pumping with standard lever

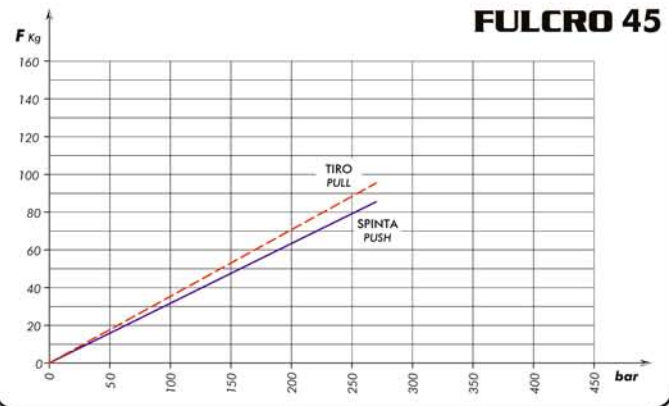
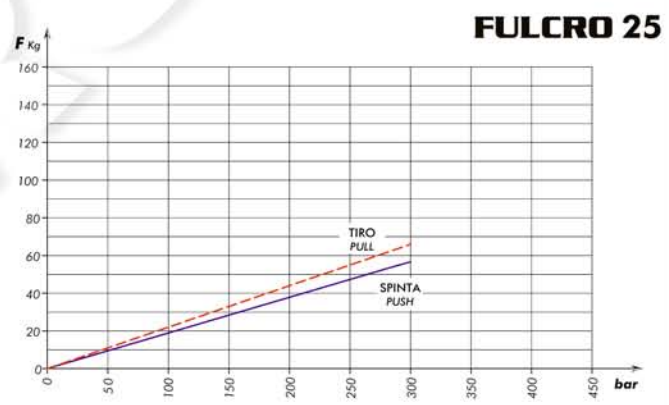
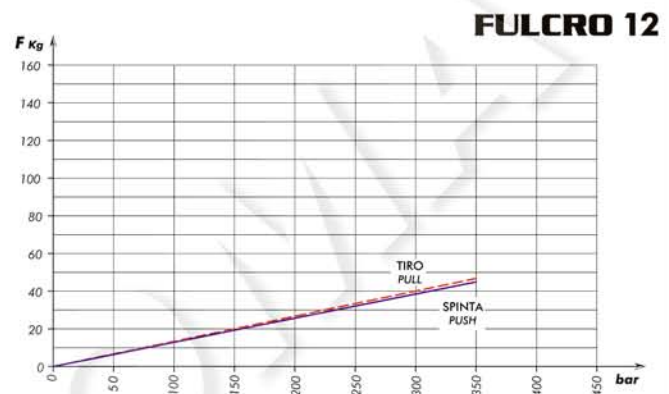

Codice fascicolo: 997-400-10610

Data: Venerdì 3 novembre 2017

Codice foglio: 997-106-00710 Rev: AP