

Part number:

HYDROMA

HYDRAULICKÉ SYSTÉMY

**HIDROMA
SISTEMS**

UKŁADY HYDRAULICZNE

HYDROMA

ГИДРАВЛИЧЕСКИЕ СИСТЕМЫ

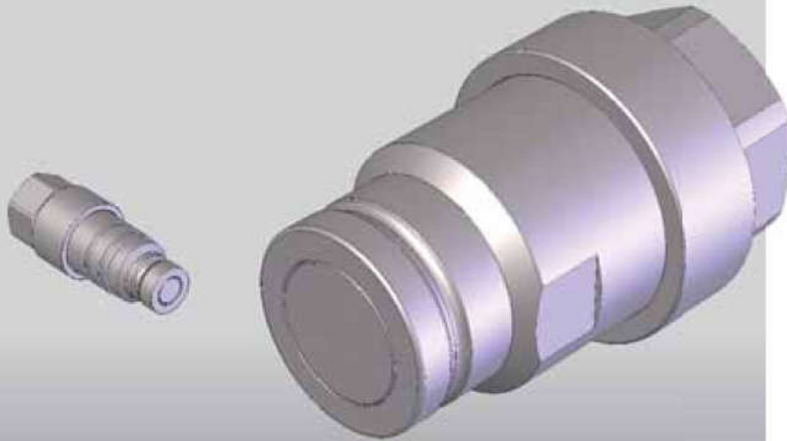

ISO 16028

MASCHIO INNESTABILE IN PRESSIONE
MALE CONNECTABLE UNDER PRESSURE
STECKER UNTER DRUCK KUPPELBAR
MALE ACCOUPABLE SOUS PRESSION

Caratteristiche tecniche

- Norma: ISO 16028
- Occlusione: faccia piana
- Aggancio: sfere radiali
- Materiale: acciaio ad alta resistenza
- Finitura: Zn-Fe (Cr III) e Zn-Ni
- Filettature: BSP - NPT - SAE - METRICHE
- Guarnizioni standard: NBR e PU
- Temperatura d'esercizio: -25 °C +100 °C
- Guarnizioni opzionali: FKM, EPDM o altro
- Pressioni di esercizio: 250-400 bar
- Connessione in pressione: consentita (solo lato maschio)
- Massima pressione residua: 250 bar

Nominal size				Max working pressure	Rated flow	Max flow rate	Min burst pressure			Fluid spillage
DNP	BG	ISO	mm				Male	Female	Coupled	
06	1	6.3	6	40	12	24	190	see PLT4	190	0,008
13	2	10	8,6	35	23	46	140	see PLT4	140	0,010
20	3	12.5	10,7	35	45	90	140	see PLT4	140	0,012
22	4A	16	12,8	35	74	150	140	see PLT4	140	0,015
25	4	19	14,8	30	100	200	120	see PLT4	120	0,020
30	5	25	17,6	30	189	280	120	see PLT4	120	0,030
39	7	40	30	25	379	700	100	see PLT1	110	0,050
50	8	50	40,6	25	757	1000	100	see PLT1	100	0,100

1 MPa = 145,04 psi • 1 l = 0,264 gal

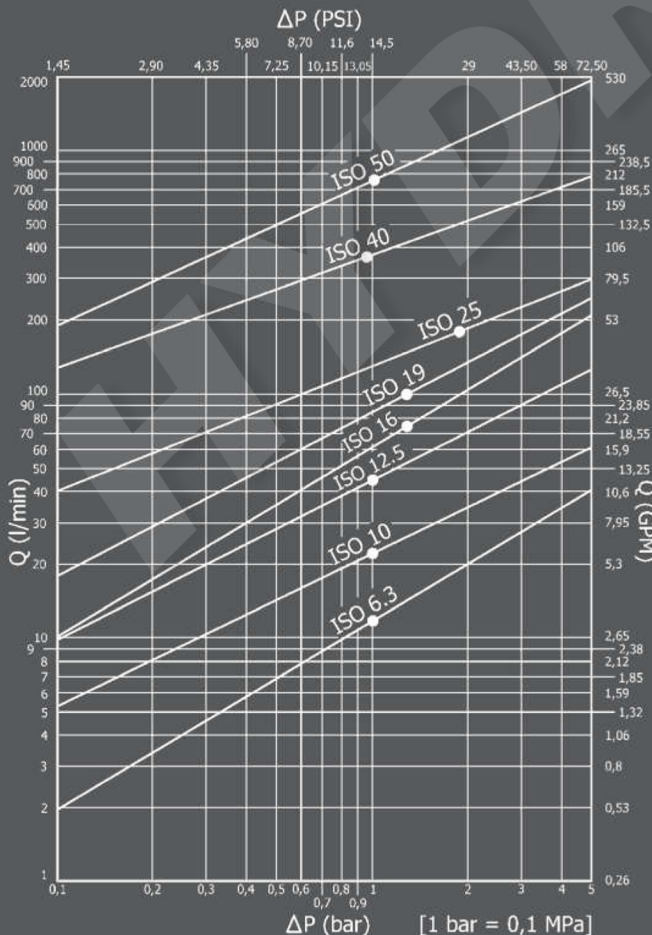

Technical data

- Standard: ISO 16028
- Occlusion: flat face
- Locking: radial balls
- Material: high resistance steel
- Finishing: Zn-Fe (Cr III) and Zn-Ni
- Threads: BSP - NPT - SAE - METRIC
- Standard seals: NBR and PU
- Working temperature: -25 °C +100 °C
- Optional seals: FKM, EPDM or more
- Working pressure: 250-400 bar
- Connection under pressure: allowed (male side only)
- Max residual pressure: 250 bar

Technische Merkmale

- Norm: ISO 16028
- Verschluss: flachdichtend
- Kupplung: Radialkugeln
- Werkstoff: hochfester Stahl
- Ausführung: Zn-Fe (Cr III) und Zn-Ni
- Gewinde: BSP - NPT - SAE - METRISCHE
- Standard-Dichtungen: NBR und PU
- Betriebstemperatur: -25 °C +100 °C
- Dichtungen nach Wahl: FKM, EPDM, usw.
- Betriebsdruck: 250-400 bar
- Kuppeln unter Druck: erlaubt (nur Steckerseite)
- Max. Restdruck: 250 bar

Caracteristiques techniques

- Norme: ISO 16028
- Obturation: clapet plat
- Accrochage: billes radiales
- Matériel: acier à haute résistance
- Traitement: Zn-Fe (Cr III) et Zn-Ni
- Taraudage: BSP - NPT - SAE - METRIQUES
- Joints standard: NBR et PU
- Température de service: -25 °C +100 °C
- Joints facultatifs: FKM, EPDM, ect.
- Pression de service: 250-400 bar
- Connexion sous pression: possible (seulement côté male)
- Pression restante max: 250 bar

PLK4 DN06 - BG 1 - ISO 6.3

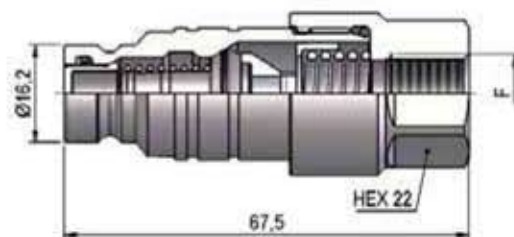

THREADS	F	STANDARD	FEMMINA - FEMALE - MUFFE - FEMELLE	MASCHIO - MALE - STECKER - MALE	Weight (g)	Packaging (pcs.)
			COD. F	COD. M		
IG 1	BSP 1/4"	DIN 3852-2-X	See PLT4 DN06	PLK4.0606.113	142	100
	NPT 1/4"	ANSI B1.20.3	See PLT4 DN06	PLK4.0606.013	143	100
IG 2	9/16"-18 UNF 2B	SAE J 1926-1	See PLT4 DN06	PLK4.0615.033	139	100

PLK4 DN13 - BG 2 - ISO 10

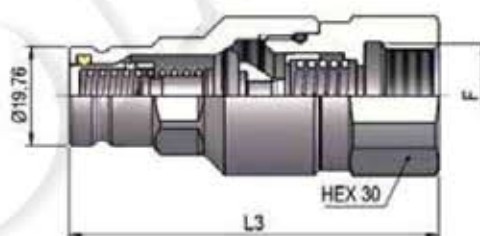

THREADS	L3	L4	F	STANDARD	FEMMINA - FEMALE - MUFFE - FEMELLE	MASCHIO - MALE - STECKER - MALE	Weight (g)	Packaging (pcs.)
					COD. F	COD. M		
IG 1	74		BSP 1/4"	DIN 3852-2-X	See PLT4 DN13	PLK4.1306.113	250	60
			BSP 3/8"	DIN 3852-2-X	See PLT4 DN13	PLK4.1310.113	240	60
	77,5		NPT 3/8"	ANSI B1.20.3	See PLT4 DN13	PLK4.1310.013	256	60
	74		BSP 1/2"	DIN 3852-2-X	See PLT4 DN13	PLK4.1313.113	226	60
	78		NPT 1/2"	ANSI B1.20.3	See PLT4 DN13	PLK4.1313.013	243	60
	74		M16x1,5	ISO 6149-1	See PLT4 DN13	PLK4.1316.103	237	60
	74		M18x1,5	ISO 6149-1	See PLT4 DN13	PLK4.1318.103	230	60
	IG 2	75		9/16"-18 UNF 2B	SAE J 1926-1	See PLT4 DN13	PLK4.1315.033	251
75			3/4"-16 UNF 2B	SAE J 1926-1	See PLT4 DN13	PLK4.1319.033	235	60
75			M22x1,5	SAE J 2244/1	See PLT4 DN13	PLK4.1322.103	222	60
AG 5	75	13	BSP 1/2"	BS B5200	See PLT4 DN13	PLK4.1313.703	211	60

THREADS

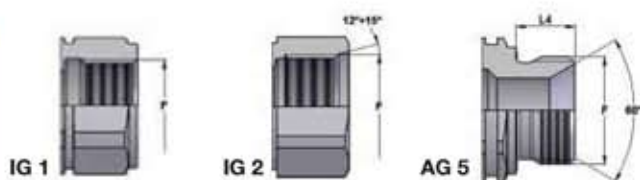

PLK4 DN20 - BG 3 - ISO 12.5

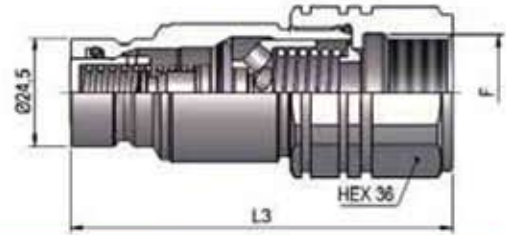

THREADS	L3	L4	F	STANDARD	FEMMINA - FEMALE - MUFFE - FEMELLE	MASCHIO - MALE - STECKER - MALE	Weight (g)	Packaging (pcs.)
					COD. F	COD. M		
IG 1	84,5		BSP 1/2"	DIN 3852-2-X	See PLT4 DN20	PLK4.2013.113	362	42
	86		NPT 1/2"	ANSI B1.20.3	See PLT4 DN20	PLK4.2013.013	375	42
	86,5		BSP 3/4"	DIN 3852-2-X	See PLT4 DN20	PLK4.2019.113	342	42
	86		NPT 3/4"	ANSI B1.20.3	See PLT4 DN20	PLK4.2019.013	347	42
	82,5		M18x1,5	ISO 6149-1	See PLT4 DN20	PLK4.2018.103	361	42
	82		M22x1,5	ISO 6149-1	See PLT4 DN20	PLK4.2022.103	344	42
	86		M26x1,5	ISO 6149-1	See PLT4 DN20	PLK4.2026.103	341	42
	86		M30x1,5	ISO 6149-1	See PLT4 DN20	PLK4.2030.103	314	42
IG 2	82		3/4"-16 UNF 2B	SAE J 1926-1	See PLT4 DN20	PLK4.2019.033	354	42
	86		7/8"-14 UNF 2B	SAE J 1926-1	See PLT4 DN20	PLK4.2023.033	366	42
	86		1"1/16-12 UN 2B	SAE J 1926-1	See PLT4 DN20	PLK4.2027.033	336	42
AG 2	93	22	1"1/16-12 UN 2A	SAE J 514	See PLT4 DN20	PLK4.2027.303	332	42
AG 5	90	16	BSP 3/4"	DIN 3852-2-A	See PLT4 DN20	PLK4.2019.713	333	42
AGS 2	112,1	41,1	7/8"-14 UNF 2A	SAE J 514	See PLT4 DN20	PLK4.2023.503	352	42
	116,4	45,4	1"1/16-12 UN 2A	SAE J 514	See PLT4 DN20	PLK4.2027.503	384	42
AGS 4	109,5	38,5	1"-14 UNS 2A	SAE J 1453	See PLT4 DN20	PLK4.2025.533	383	42

PLK4 DN22 - BG 4A - ISO 16

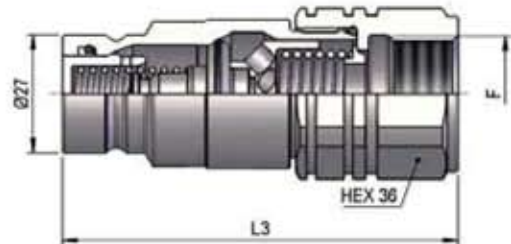

THREADS	L3	L4	F	STANDARD	FEMMINA - FEMALE - MUFFE - FEMELLE	MASCHIO - MALE - STECKER - MALE	Weight (g)	Packaging (pcs.)	
					COD. F	COD. M			
IG 1	87,5		BSP 1/2"	DIN 3852-2-X	See PLT4 DN22	PLK4.2213.113	398	42	
	89		NPT 1/2"	ANSI B1.20.3	See PLT4 DN22	PLK4.2213.013	411	42	
	89,5		BSP 3/4"	DIN 3852-2-X	See PLT4 DN22	PLK4.2219.113	378	42	
	89		NPT 3/4"	ANSI B1.20.3	See PLT4 DN22	PLK4.2219.013	383	42	
	85,5		M18x1,5	ISO 6149-1	See PLT4 DN22	PLK4.2218.103	397	42	
	85		M22x1,5	ISO 6149-1	See PLT4 DN22	PLK4.2222.103	380	42	
	89		M26x1,5	ISO 6149-1	See PLT4 DN22	PLK4.2226.103	377	42	
	89		M30x1,5	ISO 6149-1	See PLT4 DN22	PLK4.2230.103	350	42	
	IG 2	85		3/4"-16 UNF 2B	SAE J 1926-1	See PLT4 DN22	PLK4.2219.033	390	42
		89		7/8"-14 UNF 2B	SAE J 1926-1	See PLT4 DN22	PLK4.2223.033	402	42
89			1"1/16-12 UN 2B	SAE J 1926-1	See PLT4 DN22	PLK4.2227.033	373	42	
AG 2	96	22	1"1/16-12 UN 2A	SAE J 514	See PLT4 DN22	PLK4.2227.303	369	42	
AG 5	93	16	BSP 3/4"	DIN 3852-2-A	See PLT4 DN22	PLK4.2219.713	369	42	
AGS 2	115,1	41,1	7/8"-14 UNF 2A	SAE J 514	See PLT4 DN22	PLK4.2223.503	388	42	
	119,4	45,4	1"1/16-12 UN 2A	SAE J 514	See PLT4 DN22	PLK4.2227.503	420	42	
AGS 4	112,5	38,5	1"-14 UNS 2A	SAE J 1453	See PLT4 DN22	PLK4.2225.533	419	42	

PLK4 DN25 - BG 4 - ISO 19

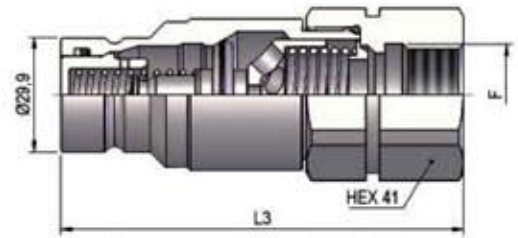

THREADS	L3	L4	F	STANDARD	FEMMINA - FEMALE - MUFFE - FEMELLE		MASCHIO - MALE - STECKER - MALE	
					COD. F	COD. M	Weight (g)	Packaging (pcs.)
IG 1	105		BSP 3/4"	DIN 3852-2-X	See PLT4 DN25	PLK4.2519.113	582	30
	105		NPT 3/4"	ANSI B1.20.3	See PLT4 DN25	PLK4.2519.013	589	30
	105		BSP 1"	DIN 3852-2-X	See PLT4 DN25	PLK4.2525.113	524	30
	105		NPT 1"	ANSI B1.20.3	See PLT4 DN25	PLK4.2525.013	531	30
	105		M30x1,5	ISO 6149-1	See PLT4 DN25	PLK4.2530.103	555	30
IG 2	105		1"1/16-12 UN 2B	SAE J 1926-1	See PLT4 DN25	PLK4.2527.033	576	30
	105		1"5/16-12 UN 2B	SAE J 1926-1	See PLT4 DN25	PLK4.2533.033	517	30
AG 5	107	18	BSP 1"	DIN 3852-2-B	See PLT4 DN25	PLK4.2525.213	525	30
	103	17	BSP 1"	BS B5200	See PLT4 DN25	PLK4.2525.703	502	30
	105	16	BSP 3/4"	DIN 3852-2-A	See PLT4 DN25	PLK4.2519.713	500	30
	107	18	BSP 1"	DIN 3852-2-A	See PLT4 DN25	PLK4.2525.713	526	30

PLK4 DN30 - BG 5 - ISO 25

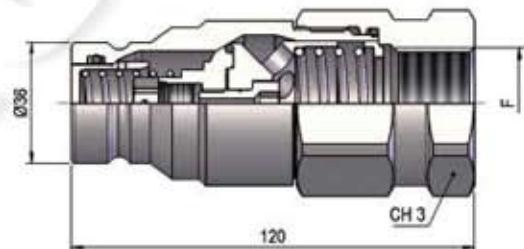

THREADS	CH3	F	STANDARD	FEMMINA - FEMALE - MUFFE - FEMELLE		MASCHIO - MALE - STECKER - MALE	
				COD. F	COD. M	Weight (g)	Packaging (pcs.)
IG 1	50	BSP 1"	DIN 3852-2-X	See PLT4 DN30	PLK4.3025.113	1038	8
	50	NPT 1"	ANSI B1.20.3	See PLT4 DN30	PLK4.3025.013	1045	8
	55	BSP 1"1/4	DIN 3852-2-X	See PLT4 DN30	PLK4.3031.113	1109	8
	55	NPT 1"1/4	ANSI B1.20.3	See PLT4 DN30	PLK4.3031.013	1123	8
IG 2	50	1"5/16-12 UN 2B	SAE J 1926-1	See PLT4 DN30	PLK4.3033.033	1028	8
	55	1"5/8-12 UN 2B	SAE J 1926-1	See PLT4 DN30	PLK4.3041.033	1111	8

THREADS

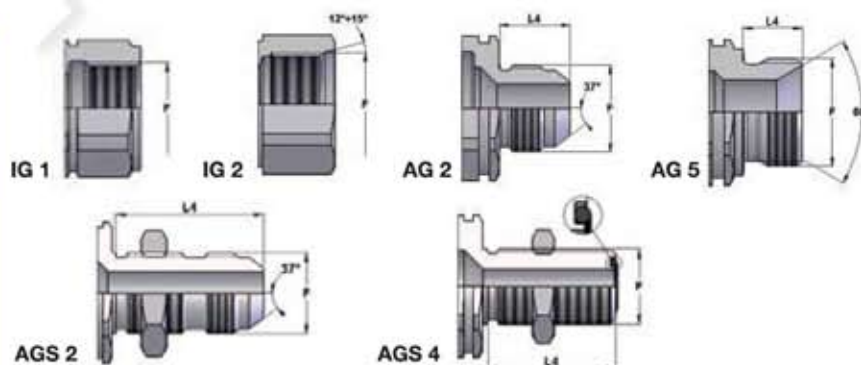

PLK4 DN39 - BG 7 - ISO 40

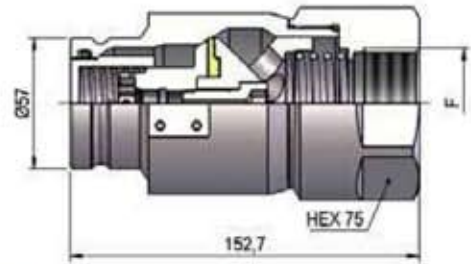

F	STANDARD	FEMMINA - FEMALE - MUFFE - FEMELLE	MASCHIO - MALE - STECKER - MALE	Weight (g)	Packaging (pcs.)
		COD. F	COD. M		
BSP 1"½	DIN 3852-2-X	See PLT1 DN39	PLK4.3939.113	3350	9
NPT 1"½	ANSI B1.20.3	See PLT1 DN39	PLK4.3939.013	3190	9

PLK4 DN50 - BG 8 - ISO 50

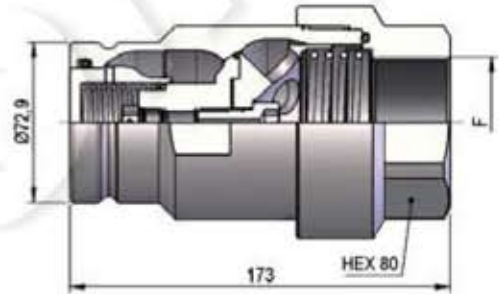

THREADS	F	STANDARD	FEMMINA - FEMALE - MUFFE - FEMELLE	MASCHIO - MALE - STECKER - MALE	Weight (g)	Packaging (pcs.)
			COD. F	COD. M		
IG 1	BSP 2"	DIN 3852-2-X	See PLT1 DN50	PLK4.5051.113	4890	6
	NPT 2"	ANSI B1.20.3	See PLT1 DN50	PLK4.5051.013	4880	6
	1"½	SAE 3000	See PLT1 DN50	PLK4.5051.003	5830	6
IG 2	2"½-12 UN 2B	SAE J 1926-1	See PLT1 DN50	PLK4.5063.033	4780	6

THREADS

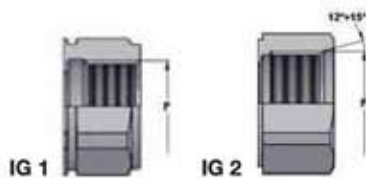

PLASTIC CAPS

NOMINAL SIZE		MALE DUST CAP				Dimensions		Weight	COLOUR	MATERIAL
DNP	BG	ISO	COD. M	D	L	D1	(g)			
06	1	6.3	SPLT.06003	26	200	20	13	●	PVC	
13	2	10	SPLT.13003	27,5	200	26	15	●	PVC	
20	3	12.5	SPLT.20003	35	200	31,5	26	●	PVC	
25	4	19	SPLT.25003	43	265	35	41	●	PVC	
30	5	25	SPLT.30003	50	280	48	66	●	PVC	

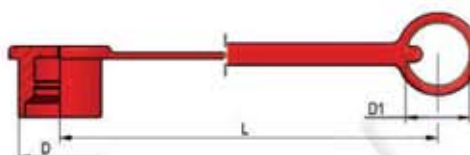

METAL CAPS

NOMINAL SIZE		MALE DUST CAP				Dimensions		Weight	MATERIAL
DNP	BG	ISO	COD. M	D	L	D1	(g)		
06	1	6.3	SPLT.06203	33	200	32	28	Aluminum	
13	2	10	SPLT.13203	30	200	32	39	Aluminum	
20	3	12.5	SPLT.20203	42	200	32	40	Aluminum	
22	4A	16	SPLT.22203	46	200	32	43	Aluminum	
25	4	19	SPLT.25203	40	275	47,5	66	Aluminum	
30	5	25	SPLT.30203	45	275	47,5	71	Aluminum	
39	7	40	SPLT.39203	68	275	47,5	155	Aluminum	
50	8	50	SPLK.50203	83	275	47,5	210	Aluminum	

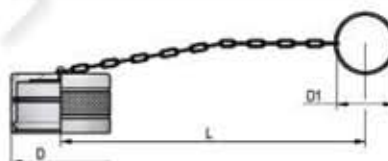

SPARE PARTS

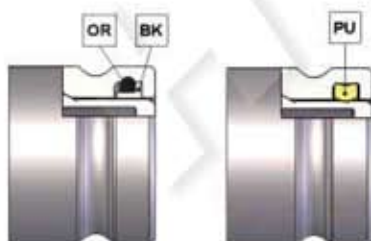

NOMINAL SIZE		MALE GASKET		MALE GASKET	
DNP	BG	ISO	OR (NBR*)	BK (PTFE)	PU (POLYURETHANE)
06	1	6.3	PLT.006.120	PLT.006.130	-
13	2	10	PLT.013.120	PLT.013.130	PLK.013.210
20	3	12.5	PLT.019.120	PLT.019.130	PVT.019.210
22	4A	16	PLT.022.120	PLT.022.130	PVT.022.210
25	4	19	PLT.025.120	PLT.025.130	PVT.025.210
30	5	25	PLT.031.121	PLT.031.131 N	-
39	7	40	PLK.039.120	PLK.039.130	-
50	8	50	PLK.050.120	PLK.050.130	-

* AL CODICE DELLA GUARNIZIONE IN NBR AGGIUNGERE 'E' PER EPDM O 'V' PER VITON
 TO THE NBR GASKET CODE ADD 'E' FOR EPDM OR 'V' FOR VITON
 ZU DER ARTIKELNR. DER NBR DICHTUNG GEBEN SIE 'E' FUER EPDM ODER 'V' FUER VITON AN
 AU CODE DU JOINT EN NBR JOINDRE 'E' POUR EPDM OU 'V' POUR VITON