

Part number:

HYDROMA

HYDRAULICKÉ SYSTÉMY

**HIDROMA
SYSTEMS**

UKŁADY HYDRAULICZNE

HYDROMA

ГИДРАВЛИЧЕСКИЕ СИСТЕМЫ

3/2 ways/positions flow diverters L700... (VS70)

RE 18302-01

Edition: 02.2016

Replaces: 05.2014



Size 4

Series 00

Maximum operating pressure 310 bar (4500 psi)

Maximum flow 20 l/min (5.3 gpm)

Ports G 1/4

General specifications

3 way 2 position valve.

Directional spool valve with direct solenoid control.

Hydraulic / pneumatic pilot , or manual push and twist control available as option.

Control spool operated by solenoid, with easily removable coil fastened by a ring nut.

Wet pin tube for DC coil, with push rod for mechanical override in case of voltage shortage.

Unrestricted 360° orientation of DC coil.

Control spool held in normal position by return spring.

Optional manual override (push-button or screw type).

Connectors available: DIN 43650 – ISO 4400, AMP

Junior, DT04-2P (Deutsch), Free leads.

Contents

Ordering details	2
Symbols	2
Functional description	3
Technical data	3
Characteristic curves	5
External dimensions and fittings	6
Electric connection	7

Ordering details

01	02	03	04	05	06	07	08
L	7	00	2				0

Family	
01	Compact directional valve
	L

Type	
02	Flow diverters
	7

Ports	
03	G 1/4 DIN 3852
	2

Control type		
04	Solenoid (coil C36) without manual override	10
	Solenoid (coil C36) with push-button type manual override	1P
	Solenoid (coil C36) with screw type manual override	1F
	Hydraulic / pneumatic control ¹⁾	P1

Spool variants		
05	Transitory position closed	3A
	Transitory position open	3N

Drain type		
06	Internal drain	I
	External drain	E

Voltage supply		31	07	04	03	01	00
07	Without coil	-	-	-	-	-	● 00
	12 V DC	●	●	●	●	●	- 0B
	13 V DC	-	●	-	-	●	- AD
	24 V DC	●	●	●	●	●	- OC
	27 V DC	-	●	-	-	●	- AC
	48 V DC	-	-	●	-	●	- OD
	110 V DC	-	-	-	-	●	- OE

Electric connections		
08	Without coils	00
	With coils, without mating connector DIN EN 175301-803 ²⁾	01
	With coils, with bi-directional diode, without mating connector vertical Amp-Junior	03
	With coils, with bi-directional diode, without mating connector horizontal Amp-Junior	04
	With coils, with bi-directional diode, without mating connector DT04-2P	07
	With coils and bipolar sheathed lead 350mm (13,8 in) long	31

● = Available - = Not available

Symbols

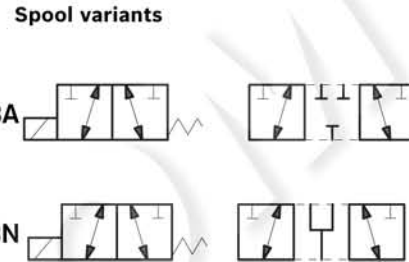
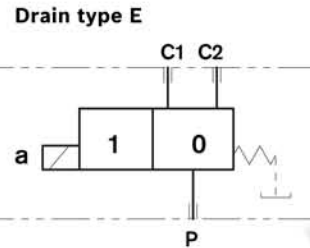
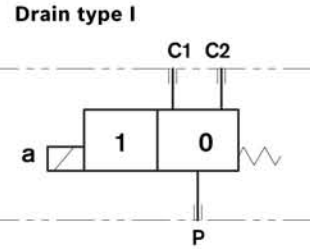

1) Minimum pressure 4 bar (58psi) with external drain (E), maximum pressure 200 bar (2901psi). With internal drain (I), at the minimum pressure (4 bar - 58psi), add the working pressure with ratio of 6,5:1. Example: With working pressure 100 bar (1450psi), minimum pilot pressure is 19.38 bar (281psi) $((100:6,5) + 4 \text{ bar (58psi)})$.

2) For connectors ordering code see data sheet RE 18325-90.

Functional description

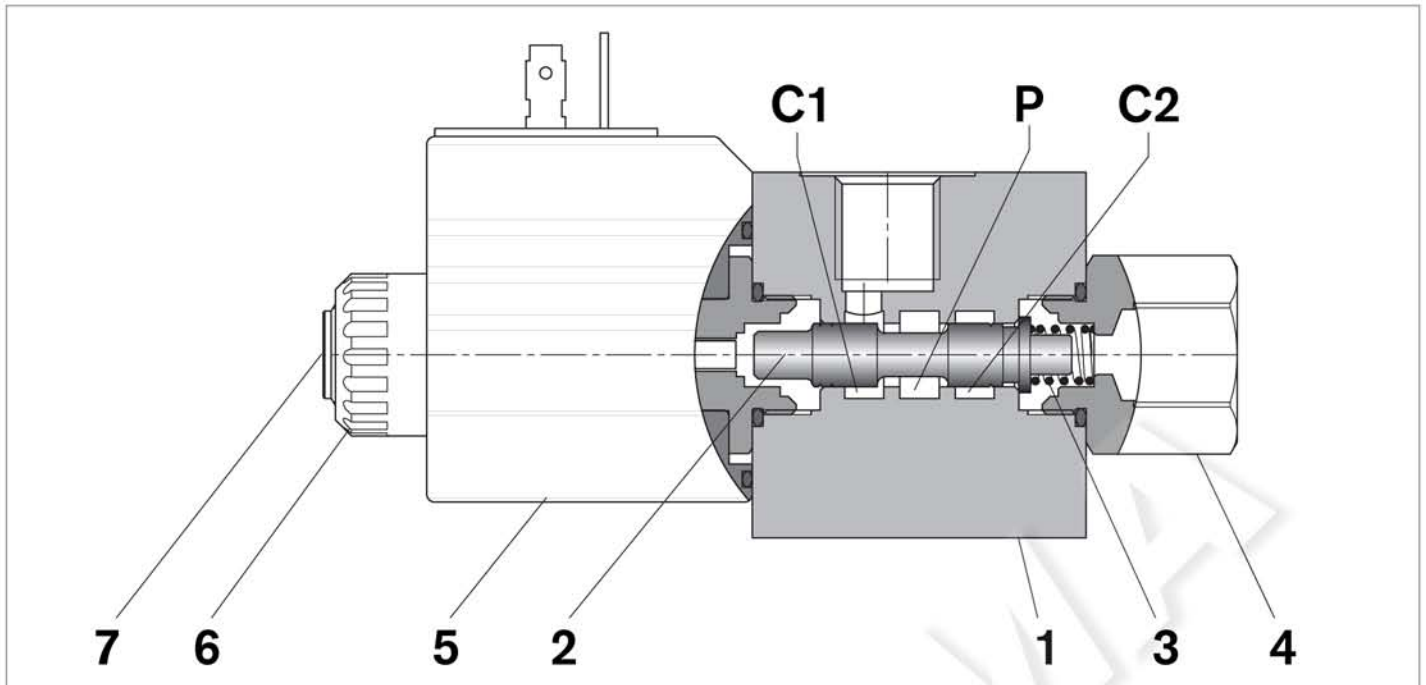

A valve basically consists of a housing (1), a control spool (2), a return spring (3) and a solenoid (5). It is designed to select which one of two circuits (C1 or C2) is to be supplied with the oil delivered from one single hose (P): with spool in position "0", when the solenoid is de-energized, the flow goes from P to C1, with spool in position "1", when the solenoid is energized the flow goes from P to C2.

With the coil de-energized, the return spring (3) pushes

back the spool (2) and holds it in position "0".

The coil (5) is fastened to the tube by the ring nut (6).

The manual override (7) allows to shift the spool (2) also in case of voltage shortage.

An external drain (4), to be connected to tank, ensures shifting operations also at higher working pressure.

Hydraulic / pneumatic pilot control for spool shifting is available upon request.

Technical data

General		
Valve weight	kg (lbs)	0.89 (1.960)
Ambient Temperature	°C (°F)	-20....+50 (-4....+122) (NBR seals)
Hydraulic		
Maximum pressure with external drain ("E" type)	bar (psi)	310 (4500)
Maximum pressure with internal drain ("I" type)	bar (psi)	250 (3625)
Maximum flow	l/min (gpm)	20 (5.3)
Hydraulic fluid		
General properties: it must have physical lubricating and chemical properties suitable for use in hydraulic systems such as, for example:		Mineral oil based hydraulic fluids HL (DIN 51524 part 1). Mineral oil based hydraulic fluids HLP (DIN 51524 part 2). For use of environmentally acceptable fluids (vegetable or polyglycol base) please consult us.
Fluid Temperature	°C (°F)	-20....+80 (-4....+176) (NBR seals)
Permissible degree of fluid contamination		ISO 4572: $\beta_x \geq 75$ X = 12...15 ISO 4406: class 20/18/15 NAS 1638: class 9
Viscosity range	mm ² /s	5....420

4 **L700... (VS70)** | 3/2 ways/positions flow diverters
 Technical data

Internal leakage with 100 bar (1450 psi) secondary pressure at C	cc/min (in ³ /min)	min.7 (0.43) max. 15 (0.74)					
Electrical							
Voltage type		DC					
Voltage tolerance (nominal voltage)	%	-10 +10					
Duty		Continuous, with ambient temperature ≤ 50°C (122°F)					
Coil wire temperature not to be exceeded	°C (°F)	150 (302)					
Insulation class		H					
Compliance with		Low Voltage Directive LVD 73/23/EC (2006/95/EC), 2004/108/EC					
Coil weight with connection EN 175301-803	kg (lbs)	0.215 (0.44)					
Voltage	V	12	13	24	27	48	110
Voltage type		DC	DC	DC	DC	DC	DC
Power consumption	W	26	26	26	26	26	26
Current (nominal at 20 °C (68 °F))	A	2.15	2.00	1.10	1.00	0.54	0.27
Resistance (nominal at 20 °C (68 °F))	Ω	5.5	6.5	22	28	89	413

Note

For applications with different specifications consult us.

Code	Voltage [V]	Connector type	Coil description	Marking	Coil Mat no.
OB 01	12 DC	EN 175301- 803 (Ex. DIN 43650)	C3601 12DC	12 DC	R933000044
OB 03	12 DC	AMP JUNIOR	C3603 12DC	12 DC	R933000047
OB 04	12 DC	AMP JUNIOR Horizontal	C3604 12DC	12 DC	R933002913
OB 07	12 DC	DEUTSCH DT 04-2P	C3607 12DC	12 DC	R933000048
OB 31	12 DC	Cable 350 mm long	C3631 12DC	12 DC	R933000045
AD 01	13 DC	EN 175301-803 (Ex. DIN 43650)	C3601 13DC	13 DC	R933000051
AD 07	13 DC	DEUTSCH DT 04-2P	C3607 13DC	13 DC	R933000049
OC 01	24 DC	EN 175301-803 (Ex. DIN 43650)	C3601 24DC	24 DC	R933000053
OC 03	24 DC	AMP JUNIOR	C3603 24DC	24 DC	R933000057
OC 04	24 DC	AMP JUNIOR Horizontal	C3604 24DC	24 DC	R933002914
OC 07	24 DC	DEUTSCH DT 04-2P	C3607 24DC	24 DC	R933000058
OC 31	24 DC	Cable 350 mm long	C3637 24DC	24 DC	R933000055
AC 01	27 DC	EN 175301-803 (Ex. DIN 43650)	C3601 27DC	27 DC	R933000056
AC 07	27 DC	DEUTSCH DT 04-2P	C3607 27DC	27 DC	R933000050
OD 01	48 DC	EN 175301-803 (Ex. DIN 43650)	C3601 48DC	48 DC	R933000059
OD 04	48 DC	AMP JUNIOR Horizontal	C3604 48DC	48 DC	R933002915
OE 01	110 DC	EN 175301-803 (Ex. DIN 43650)	C3601 110DC	110 DC	R933000061

Characteristic curves

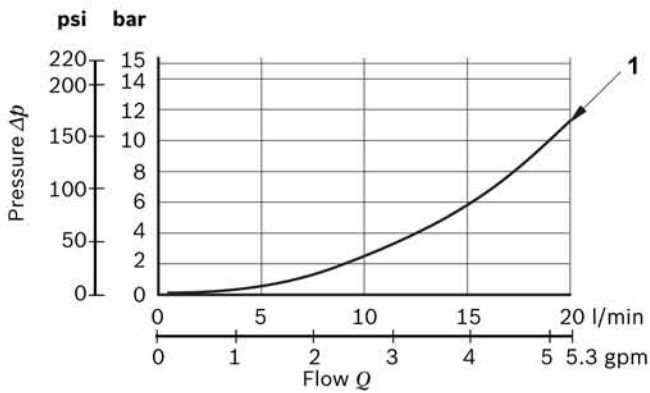

Flow path	Curve no.
P1 > C1	1
P1 > C2	1

Measured with hydraulic fluid ISO-VG32 at 45° ±5 °C (113° ±9 °F); ambient temperature 20 °C (68 °F).

Performance limits

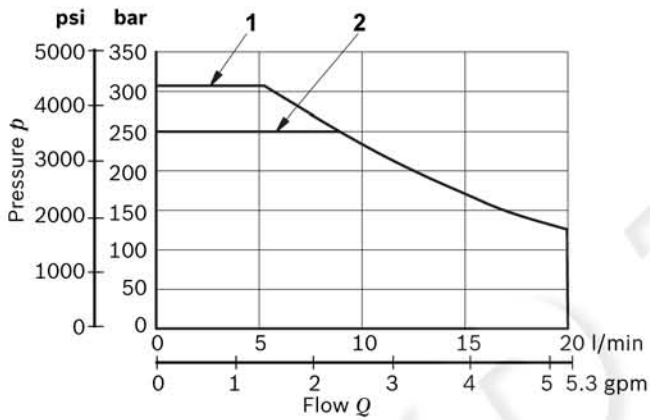

Drain type	Curve No.
External (-E-)	1
Internal (-I-)	2

External dimensions and fittings

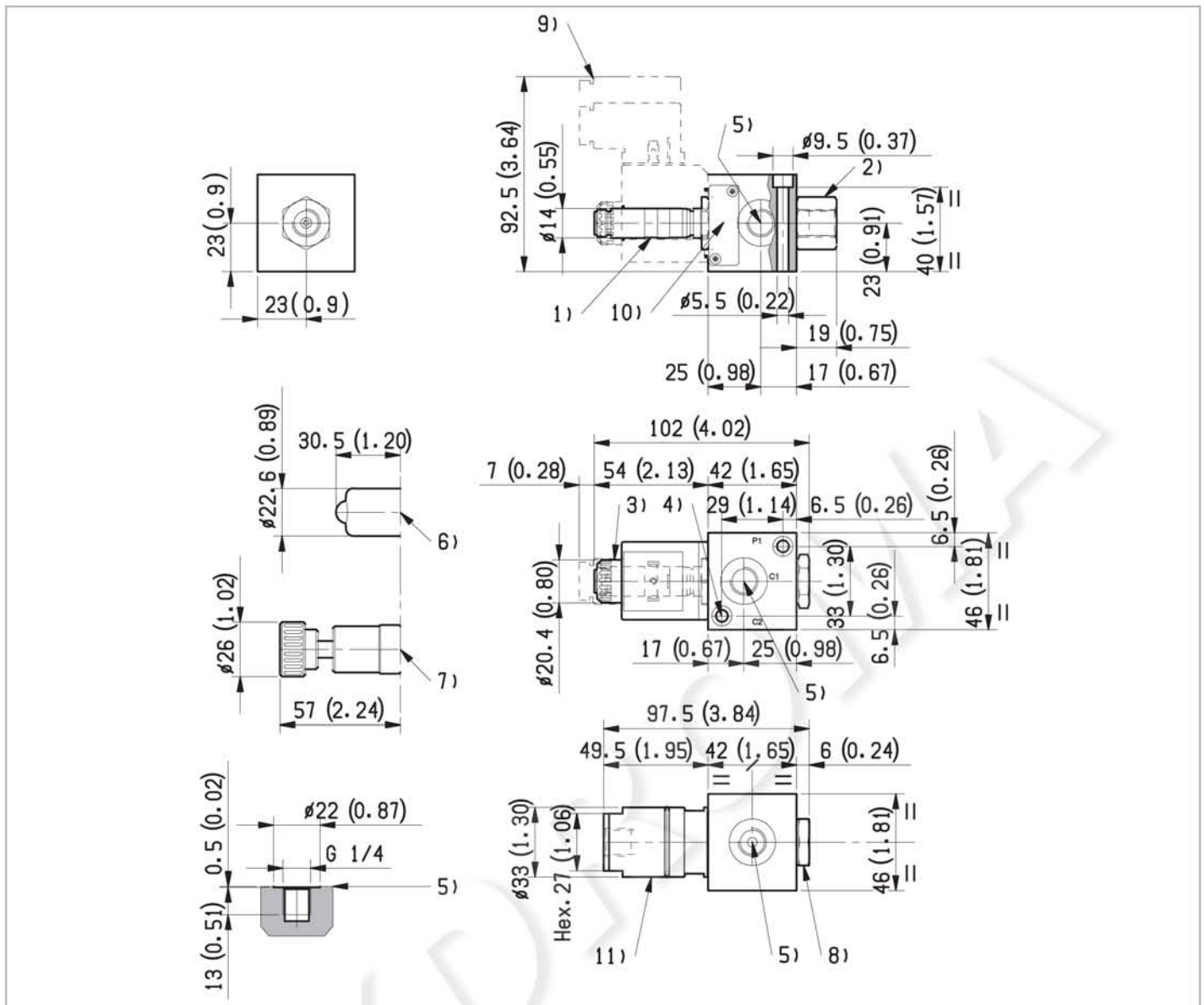

- 1 Solenoid tube \varnothing 14 mm (0.55 inch).
- 2 Plug for version with external drain.
- 3 Ring nut for coil locking \varnothing 20,4 mm (8 inch). Torque 3 – 4 Nm (2.2 – 3.0 ft-lb).
- 4 Two through holes for installation. Recommended screws M5 with strength class DIN 8.8. Torque 5-6Nm(3.6-4.4 ft-lb).
- 5 Ports P, C1, C2, External drain, hydraulic/pneumatic pilot port G 1/4.
- 6 Optional push-button type manual override for spool opening: it is pressure stuck to the ring nut 5-6Nm (3.7-4.4 ft-lb) for coil locking. Mat no. R933000042.
- 7 Optional screw type manual override for spool opening: it is screwed torque 6-7Nm (4.4-5.2 ft-lb) to the tube as replacement of the coil ring nut. Mat no. R933000021.
- 8 Plug for version with internal drain.
- 9 Minimum clearance needed for connector removal.
- 10 Identification label.
- 11 Hydraulic, or pneumatic pilot connector.

Electric connection

