

Part number:

HYDROMA

HYDRAULICKÉ SYSTÉMY

**HIDROMA
SISTEMS**

UKLADY HYDRAULICZNE

HYDROMA

ГИДРАВЛИЧЕСКИЕ СИСТЕМЫ

Check, poppet type

Common cavity, Size 10

VUCN-10A

04.31.23.00.85 - Z

RE 18318-90

Edition: 01.2019

Replaces: 03.2016



Technical data

Max. operating pressure	350 bar (5000 psi)
Max. flow	80 l/min (21 gpm)
Max. internal leakage	5 drops/min.
Fluid temperature range	-30 to 100 °C (-22 to 212 °F)
Installation torque	41 - 47 Nm (30 - 35 ft-lbs)
Weight	0.15 kg (0.33 lbs)
Cavity	CA-10A-2N (see data sheet 18325-70)
Lines bodies and standard assemblies	Please refer to section "Hydraulic integrated circuit" or consult factory
Seal kit ¹⁾	Code: RG10A2010520100 material no: R901111363
Fluids	Mineral-based or synthetics with lubricating properties at viscosities of 5 to 800 mm ² /s (cSt)
Recommended degree of fluid contamination	Nominal value max. 10µm (NAS 8) / ISO 4406 20/18/15
Installation position	No restrictions
Other Technical Data	See data sheet 18350-50

Description

When pressure at 1 rises above the spring bias pressure, the poppet is lifted and flow allowed from 1 to 2. The valve is closed (checked) from 2 to 1. Precision machining and hardening processes allow virtually leak-free performance in the checked condition.

1) Only external seals for 10 valves

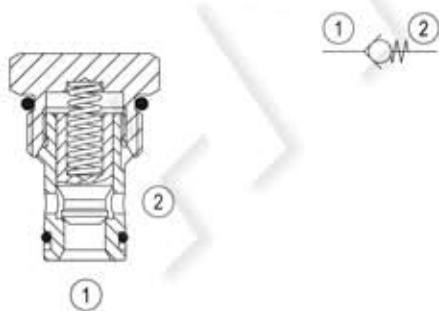

Characteristic curve

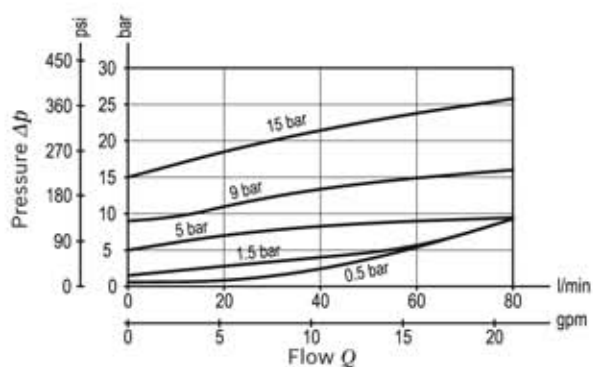

Ordering code

04.31.23.00	85	Z	00	*
-------------	----	---	----	---

Series 0/A to L
unchanged performances and dimensions

Version and options standard

Check, poppet type

85 Common cavity, Size 10

SPRINGS	
	Cracking pressure bar (psi)
00	0.5 (7.25)
01	1.4 (20)
05	5 (75)
09	9 (131)
15	15 (220)

Preferred types

Type	Material number
043123008500000	R901106596
043123008501000	R930005884
043123008505000	R901106601
043123008509000	R930000962
04312300851500A	R901106602

Type	Material number

Dimensions

