

Part number:

HYDROMA

HYDRAULICKÉ SYSTÉMY

**HIDROMA
SYSTEMS**

UKŁADY HYDRAULICZNE

HYDROMA

ГИДРАВЛИЧЕСКИЕ СИСТЕМЫ

ELECTRO-PROPORTIONAL VALVES—FLOW CONTROL

SP12-20 Poppet, 2-Way, Normally Closed

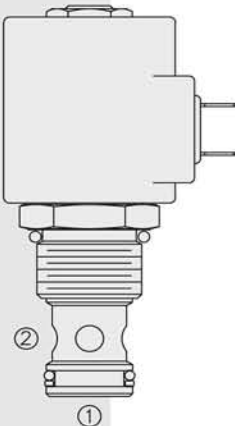

DESCRIPTION

A proportional solenoid-operated, two-way, poppet-type, normally closed, screw-in hydraulic cartridge valve for low-leakage blocking and load-holding applications.

OPERATION

When de-energized, the **SP12-20** acts as a check valve, allowing flow from 1 to 2, and blocking flow from 2 to 1. When energized, the 2 to 1 flow path opens. Flow is proportional to current applied to the coil. Flow varies with manual override options.

Note: If low voltage is expected on the machine, 12 or 24 volt systems will require the use of 10 volt or 20 volt coils respectively. See "SP Valves and Coil Operating Parameters," page 2.002.1.

FEATURES

- Industry-common cavity.
- Continuous-duty rated coils.
- Manual override option.
- Efficient wet-armature construction.
- Optional waterproof E-Coils rated up to IP69K.
- Metering Option.

RATINGS

Operating Pressure: 250 bar (3625 psi)

Flow: Without Manual Override: 100 lpm (27 gpm) at 34.5 bar (500 psi)

With Manual Override M or T: 95.6 lpm (25.25 gpm) at 34.5 bar (500 psid)

With Manual Override Y or J: 68.1 lpm (18 gpm) at 34.5 bar (500 psid)

Minimum Operating Dither/Pulse Frequency: 70 Hz

Hysteresis: Less than 5% below 60% of I-max.; Less than 10% above 60% of I-max.

Max. Internal Leakage: 5 drops per minute at 250 bar (3625 psi)

Temperature: -40 to 120°C with standard Buna seals

Fluids: Mineral-based or synthetics with lubricating properties at viscosities of 7.4 to 420 cSt (50 to 2000 sus); See Temperature and Oil Viscosity, page 9.060.1

Filtration: See page 9.010.1; **Installation:** No Restrictions. See page 9.020.1

Cavity: VC12-2; See page 9.112.1; **Cavity Tool:** CT12-2XX; See page 8.600.1

Seal Kit: SK12-2X-T; See page 8.650.1

Coil Nut: Part No. 7004400; for E-coils manuf. prior to 1-1-04, see page 3.400.1.

SYMBOLS

USAS/ISO:

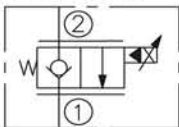

PERFORMANCE

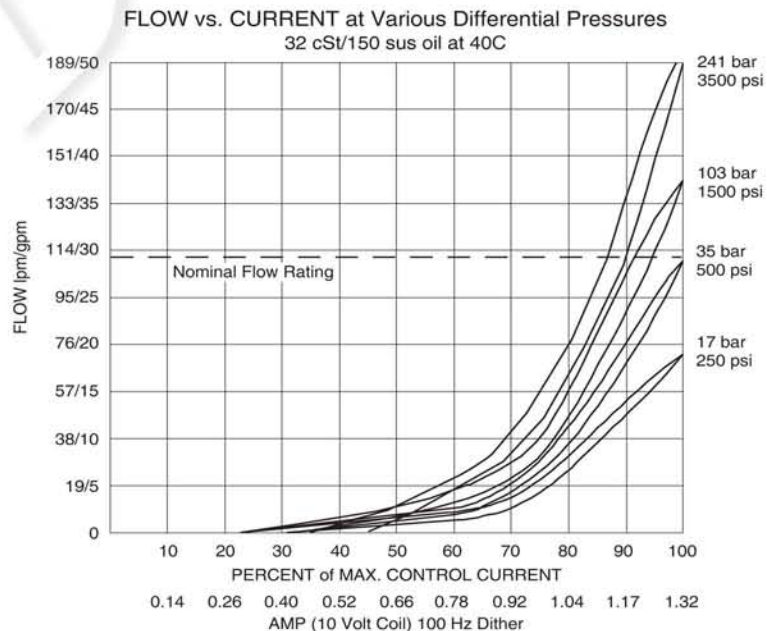
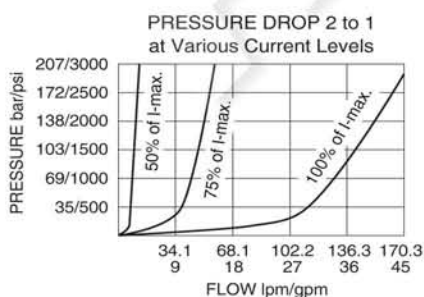
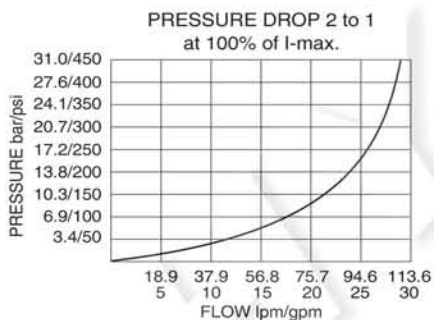

PERFORMANCE (cont'd.)

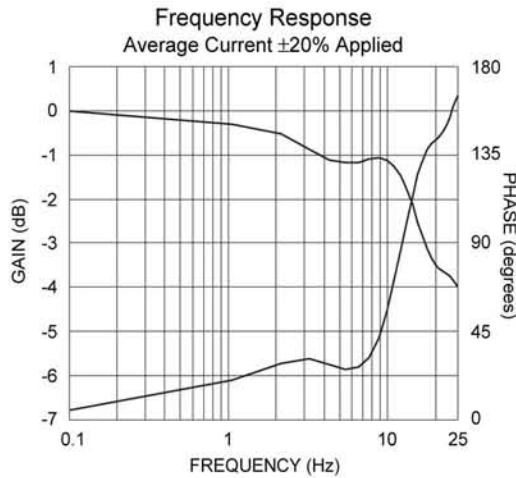

Recommended Electronic Controllers:
See page 2.001.1 or our Electronics catalog.

DIMENSIONS

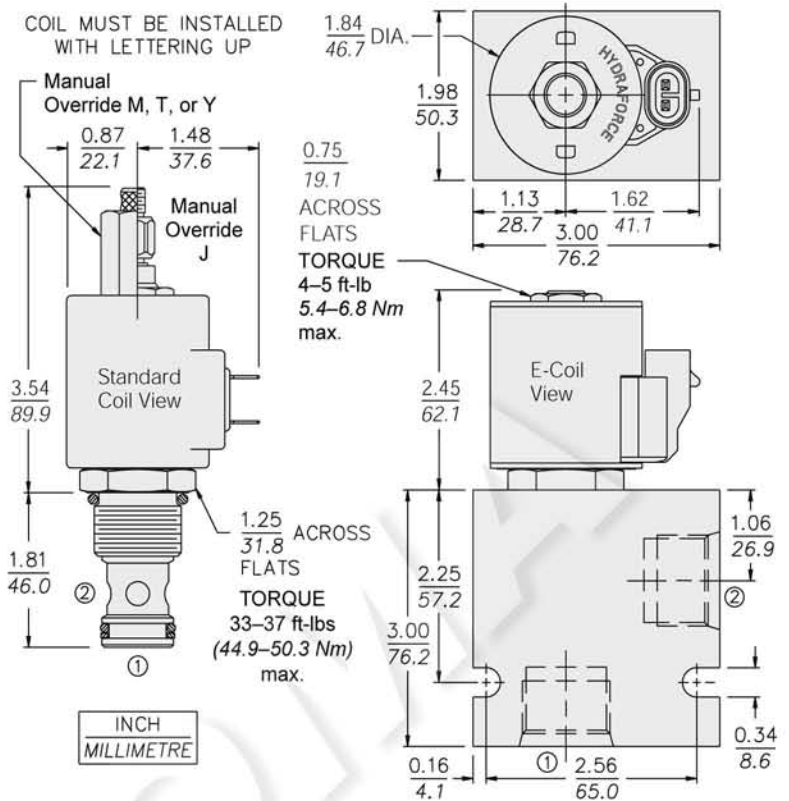

MATERIALS

Cartridge: Weight: 0.25 kg. (0.55 lbs.) Steel with hardened work surfaces. Zinc-plated exposed surfaces. Buna N O-rings and back-ups standard.

Standard Ported Body: Weight: 0.57 kg. (1.25 lbs.) Anodized high-strength 6061 T6 aluminum alloy, rated to 207 bar (3000 psi). Ductile iron bodies available. dimensions may differ. See page 8.012.1.

Standard Coil: Weight: 0.27 kg. (0.60 lbs.) Unitized thermoplastic encapsulated, Class H high temperature magnetwire. See page 3.200.1.

E-Coil: Weight: 0.41 kg. (0.9 lbs.) Perfect wound, fully encapsulated with rugged external metal shell. Rated up to IP69K with integral connectors. **Note: See page 3.400.1 for all E-Coil retrofit applications.**

TO ORDER

