

Part number:

HYDROMA

HYDRAULICKÉ SYSTÉMY

**HIDROMA
SISTEMS**

UKŁADY HYDRAULICZNE

HYDROMA

ГИДРАВЛИЧЕСКИЕ СИСТЕМЫ

Male stud elbow (body only)
Winkel-Einschraubstutzen
Sroubení úhlové (pouze tělo)

WES MK

Stud thread: metric (taper)

Einschraub-
gewinde: Metrisches Gewinde (kegelig)

Závit čepu: metrický (kuželový)

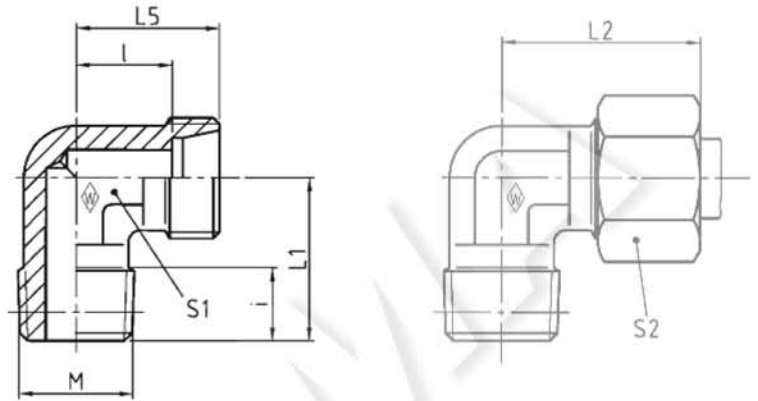

Series	bar	Tube OD	Type	Reference	kg per 100 pcs.	L ₁	L ₂	L ₅	l	i	S ₁	S ₂	
Reihe	PN	Rohr-AD	Typ	Best.-Nr.	kg per 100 St.								
Řada	bar	Vnější prům. trubky M	Typ	Ref.	kg na 100 p.								
LL	100 (1450)	4	M 8 x 1 keg	WES 4 LLMK	WAL037714	17	21	15	11	8	9	10	
		6	M 10 x 1 keg	WES 6 LLMK	WAL037716	17	21	15	9,5	8	9	12	
		8	M 10 x 1 keg	WES 8 LLMK	WAL037717	20	23	17	11,5	8	12	14	
L	250 (3626)	6	M 10 x 1 keg	WES 6 LMK	WAL037718	20	27	19	12	8	12	14	
		8	M 12 x 1,5 keg	WES 8 LMK	WAL037719	26	29	21	14	12	12	17	
		10	M 14 x 1,5 keg	WES 10 LMK	WAL037720	27	30	22	15	12	14	19	
		12	M 16 x 1,5 keg	WES 12 LMK	WAL037721	28	32	24	17	12	17	22	
		15	M 18 x 1,5 keg	WES 15 LMK	WAL037722	8,1	32	36	28	21	12	19	27
	160 (2321)	18	M 22 x 1,5 keg	WES 18 LMK	WAL037723	12,2	36	40	31	23,5	14	24	32
S	630* (9137)	6	M 12 x 1,5 keg	WES 6 SMK	WAL037724	26	31	23	16	12	12	17	
		8	M 14 x 1,5 keg	WES 8 SMK	WAL037725	27	32	24	17	12	14	19	
		10	M 16 x 1,5 keg	WES 10 SMK	WAL037726	28	34	25	17,5	12	17	22	
		12	M 18 x 1,5 keg	WES 12 SMK	WAL037727	28	38	29	21,5	12	17	24	
		14	M 20 x 1,5 keg	WES 14 SMK	WAL037728	10,3	32	40	30	22	14	19	27
	400 (5801)	16	M 22 x 1,5 keg	WES 16 SMK	WAL037729	11,4	32	43	33	24,5	14	24	30

L₂ = approximate length with nut tightened
L₂ = Ungefährmaß bei angezogener Überwurfmutter
L₂ = přibližná délka při utažené převlečné matici

* PN 630 only applies to taper port forms; PN 400 is applicable to parallel port forms
* PN 630 nur bei kegeligen Einschraublöchern, sonst PN 400
* PN 630 pouze u kuželovitých závitových otvorů; u paralelních závitových otvorů PN 400