

Part number:

HYDROMA

HYDRAULICKÉ SYSTÉMY

**HIDROMA
SISTEMS**

UKŁADY HYDRAULICZNE

HYDROMA

ГИДРАВЛИЧЕСКИЕ СИСТЕМЫ

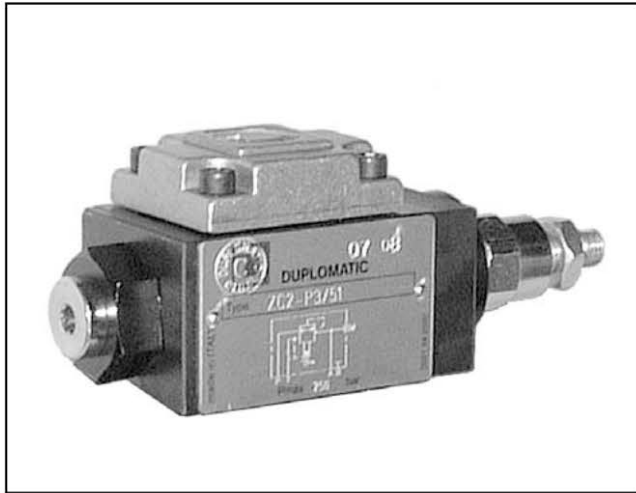

ZC2

BALANCING VALVES

SERIES 51

SUBPLATE MOUNTING ISO 4401-03 (CETOP 03)

p max 350 bar
Q max 25 l/min

MOUNTING INTERFACES

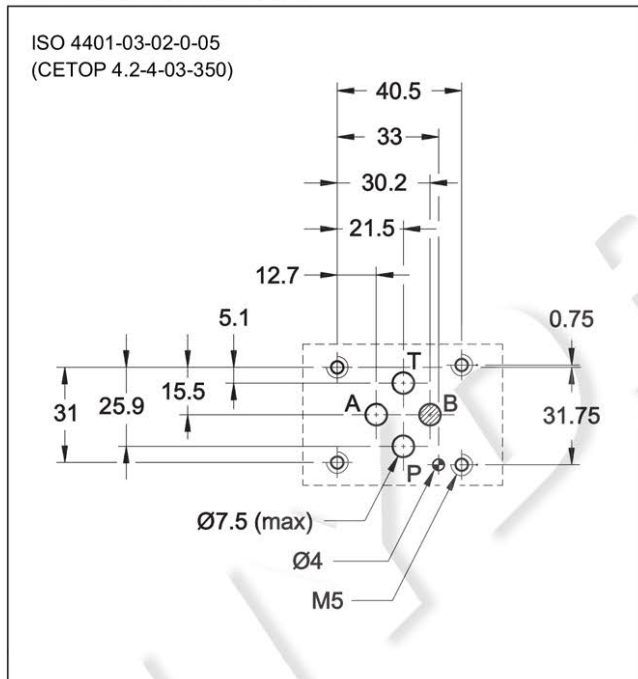

OPERATING PRINCIPLE

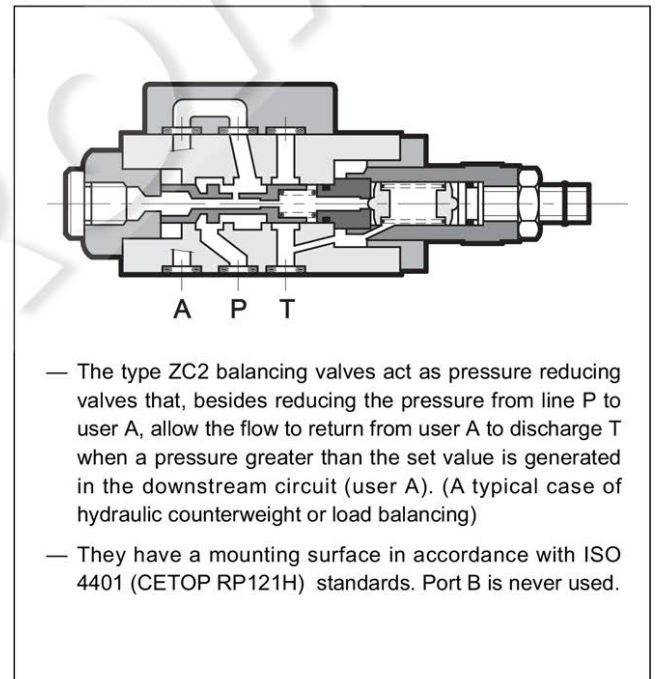

PERFORMANCES (measured with mineral oil of viscosity 36 cSt at 50°C)

Maximum operating pressure	bar	350
Maximum flow rate	l/min	25
Ambient temperature range	°C	-20 / +50
Fluid temperature range	°C	-20 / +80
Fluid viscosity range	cSt	10 ÷ 400
Fluid contamination degree	According to ISO 4406:1999 class 20/18/15	
Recommended viscosity	cSt	25
Mass:	kg	1,3

HYDRAULIC SYMBOL

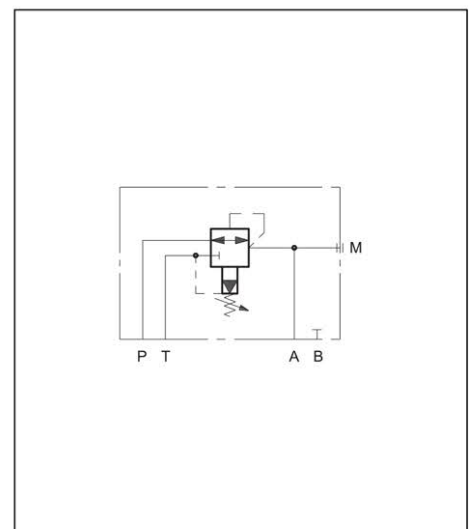

1 - IDENTIFICATION CODE

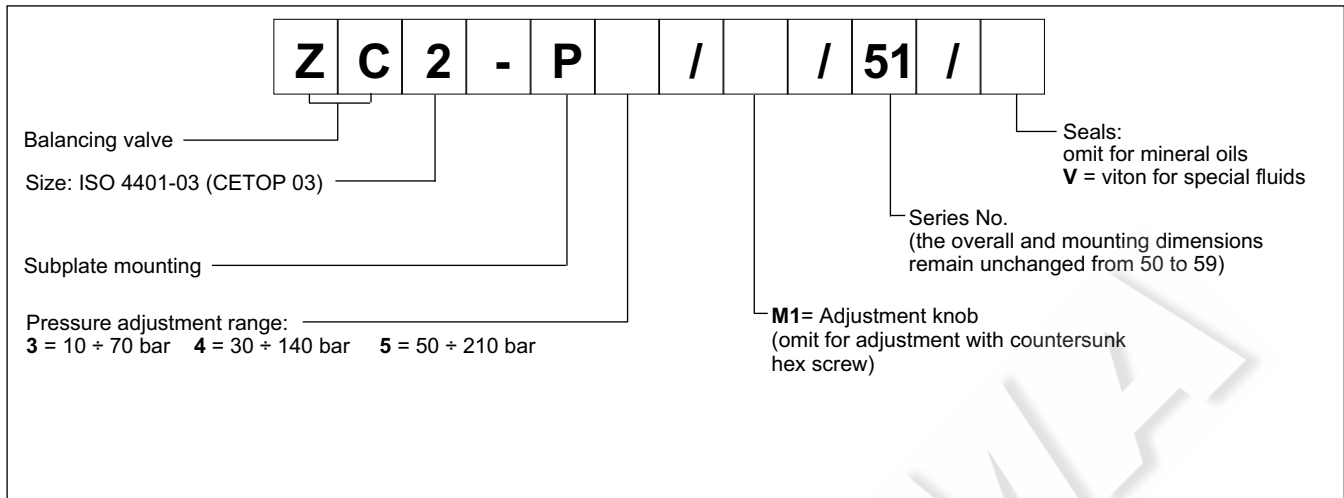

2 - CHARACTERISTIC CURVES

(values obtained with viscosity of 36 cSt at 50°C)

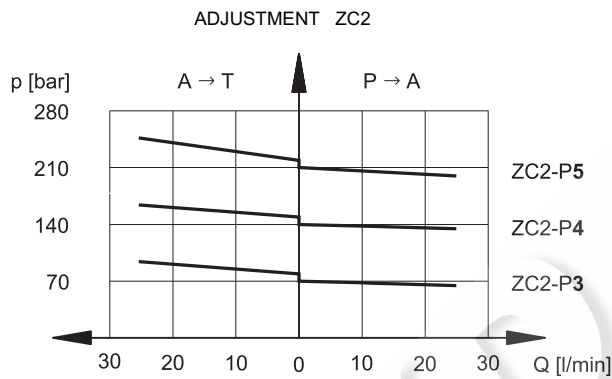

3 - HYDRAULIC FLUIDS

Use mineral oil-based hydraulic fluids HL or HM type, according to ISO 6743-4. For these fluids, use NBR seals. For fluids HFDR type (phosphate esters) use FPM seals (code V). For the use of other kinds of fluid such as HFA, HFB, HFC, please consult our technical department.

Using fluids at temperatures higher than 80 °C causes a faster degradation of the fluid and of the seals characteristics. The fluid must be preserved in its physical and chemical characteristics.

4 - ZC2 OVERALL AND MOUNTING DIMENSIONS

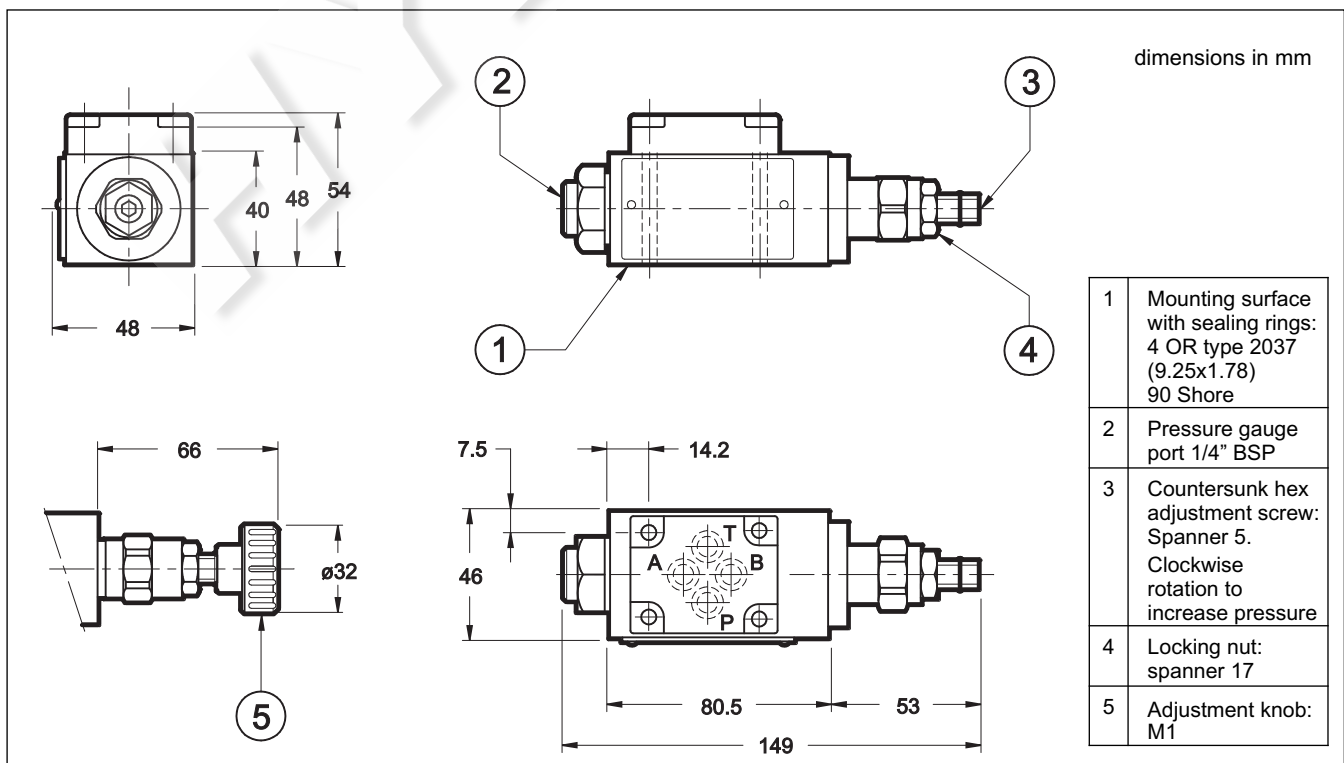

9 - INSTALLATION

The ZC2 valves can be installed in any position without impairing correct operation.

Valves are fixed by means of screws or tie rods on a flat surface with planarity and roughness equal to or better than those indicated in the relative symbols. If minimum values are not observed, fluid can easily leak between the valve and support surface.

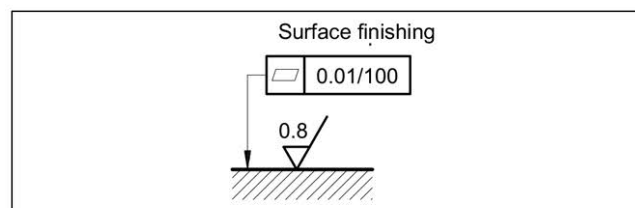

6 - FASTENING BOLTS

N. 4 bolts M5x55
Tightening torque: 5Nm (A screws 8.8)

7 - SUBPLATES (see cat. 51 000)

Type PMMD-AI3G ports on rear 3/8" BSP
Type PMMD-AL3G side ports 3/8" BSP