

Part number:

HYDROMA

HYDRAULICKÉ SYSTÉMY

**HIDROMA
SYSTEMS**

UKŁADY HYDRAULICZNE

HYDROMA

ГИДРАВЛИЧЕСКИЕ СИСТЕМЫ

Single-acting flow/braking control valves with and without bleed air execution

FT 243/5

Single-acting flow control valves available from 1/4" to 3/4" size - METRIC THREADS. Max. working pressure 300 Bar, adjustable oil flow rate from 0,2 to 80 Lt./min. (depending on the size)

Single-acting control

No pressure compensated flow control

METRIC threads

Carbon steel

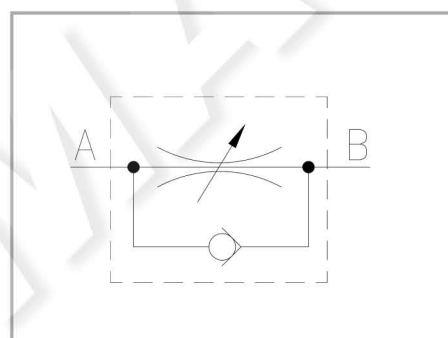

Technical information

Technical description

They are composed of a needle throttling, inside which there is a ball single-acting valve. They can be used in the assembling in manifolds and integrated blocks and are also used as cylinder braking valves. The model FT 243/5-S can be used also as air breather. By removing the cap nut it is possible to unscrew the needle and uncover the coaxial passage which allows the breather of the underlying chamber. Recommended filtration: 60 micron or inferior. Max. working pressure: 300 bar

Materials

CORPO / BODY	Acciaio legato/Alloy Steel
SPILO DI REGOLAZIONE / ADJUSTING NEEDLE	Acciaio/Steel 35 S Mn Pb 10-UNI EN 10083- AISI 303
GUARNIZIONI / GASKETS	Di serie NBR - A richiesta FPM/Standard NBR-on demand FPM
DADO / NUT	Acciaio/Steel 35 S Mn Pb 10-UNI EN 10083
ANELLI ANTIESTRUSIONE / ANTIEXTRUSION RINGS	PTFE

Technical data

TIPO / TYPE	PRESSIONE ESERCIZIO BAR / WORKING PRESSURE BAR	MIN. PRESSIONE SCOPPIO BAR / MIN. BURSTING PRESSURE BAR	TEMPERATURA ESERCIZIO / WORKING TEMPERATURE	GRADO DI FILTRAZIONE μm / FILTRATION GRADE μm
14	300	1300	-20°C/+100°C	25
38	300	1300	-20°C/+100°C	25
12	300	1300	-20°C/+100°C	25
34	300	1300	-20°C/+100°C	25

Dimensional tables and drawings

FT 243/5											
TIPO	ϕA	ϕB	C	D	Es. 1	Es. 2	Es. 3	(1) OR	(2) BK	(3) OR	PESO / WEIGHT KG
14	M17x1	10	8,5	44,5	22	17	4	106	106	2056	0,046
38	M18x1	11	8,5	45,5	24	17	5	2031	2031	2062	0,055
12	M22x1,5	14	14	66,5	27	19	7	2043	2043	2075	0,107
34	M27x1,5	18	18	82,0	32	22	9	2056	2056	3093	0,189

FT 243/5-S											
TIPO	ϕA	ϕB	C	D	Es. 1	Es. 2	Es. 3	(1) OR	(2) BK	(3) OR	PESO / WEIGHT KG
14	M17x1	10	8,5	59	22	17	4	106	106	2056	0,046
38	M18x1	11	8,5	59	24	17	5	2031	2031	2062	0,055
12	M22x1,5	14	14	87	27	19	7	2043	2043	2075	0,107
34	M27x1,5	18	18	106	32	22	9	2056	2056	3093	0,189

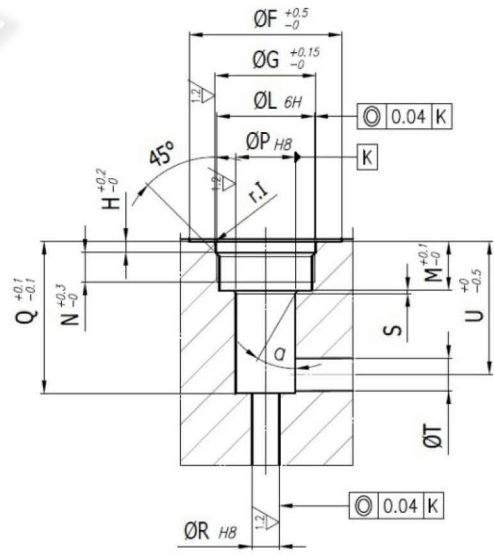
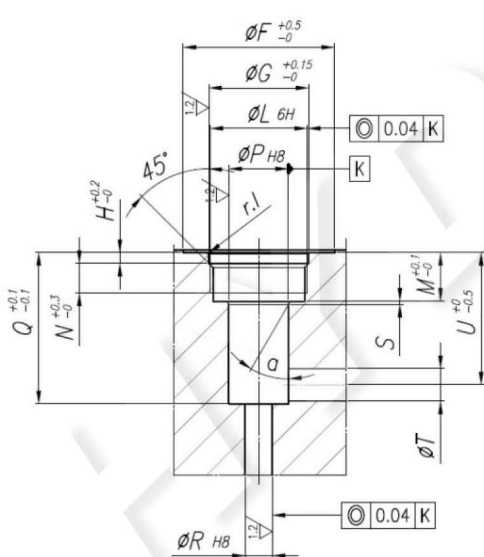
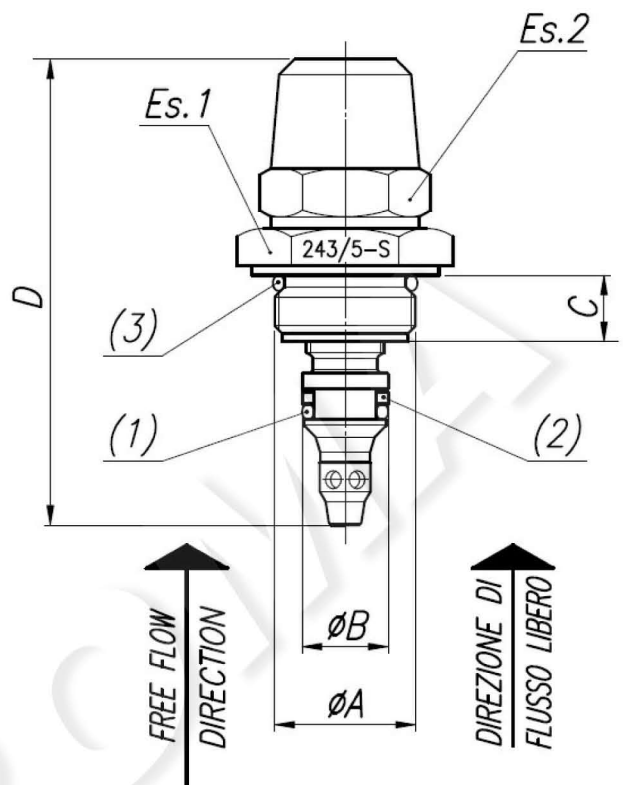
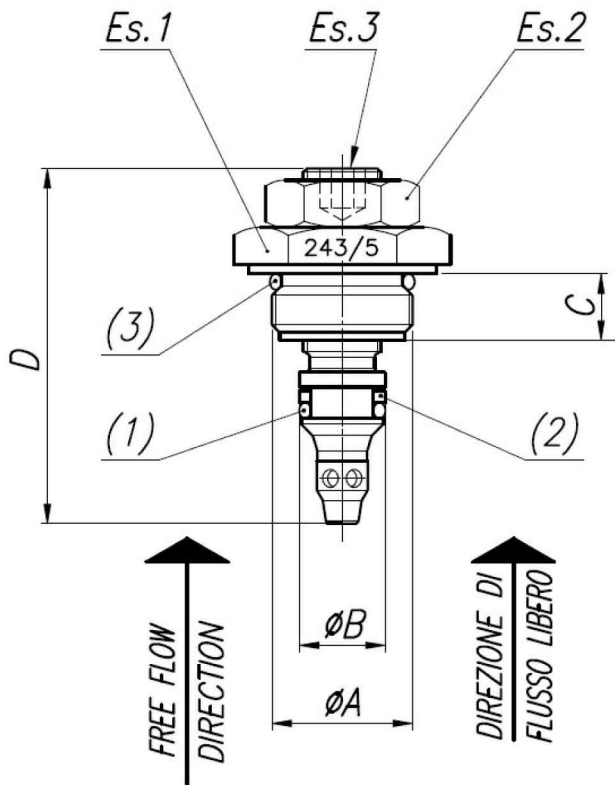

	$\varnothing F$	$\varnothing G$	H	$\varnothing L$	M	N	$\varnothing P$	Q	$\varnothing R$	S	$\varnothing T$	U	r.I	α
14	26	17.5	2	M17x1	9	5.5	10	28	4	0.6	4.5	25	0.3	30°
38	28	18.5	2	M18x1	9	5	11	28	5	0.6	6	24.5	0.3	30°
12	33	22.5	2.5	M22x1.5	15	10	14	40.5	8	1	8	36	0.3	20°
34	35	28	3.5	M27x1.5	21	15	18	54.5	10	1.5	10	48.5	0.5	20°

Flow rate curves

