

Part number:

FT 243/2

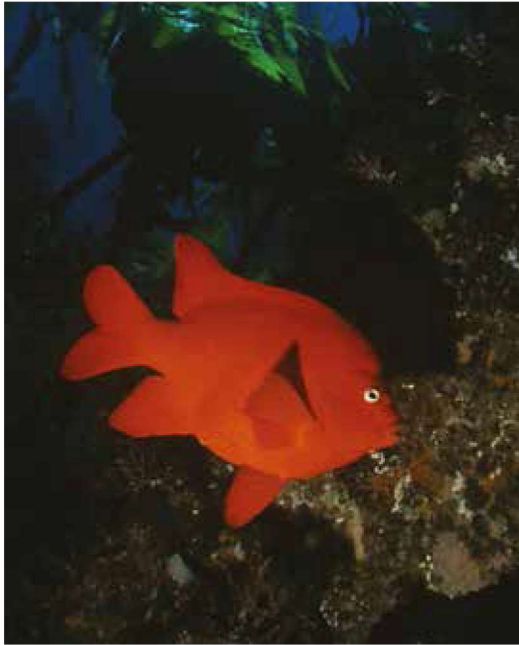

MATERIALS

| | |
|--------|----------------------|
| BODY | ETG 100 |
| NEEDLE | 35SMNPB10 - AISI 303 |
| OR | NITRILE |
| NUT | 35SMNPB10 |
| BK | PTFE |

EXAMPLE FOR ORDERING

| | CODE | TYPE | VITON SEAL |
|-----------------|-----------|------|------------|
| STEEL | FT 243/2 | 34 | V |
| STAINLESS STEEL | FT 2243/2 | 34 | - |

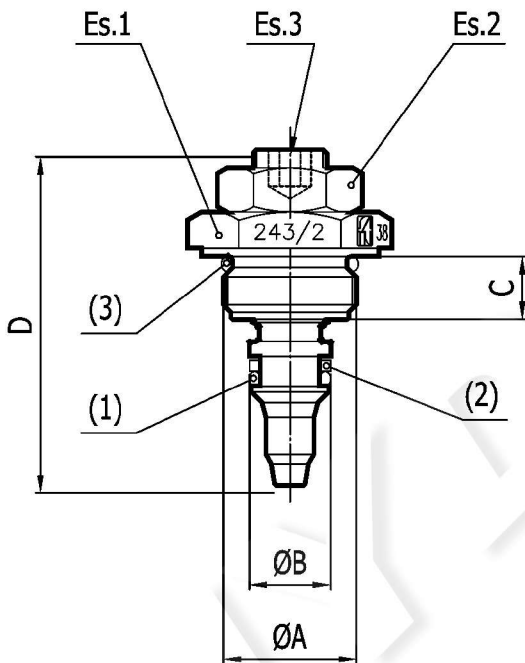

DIMENSIONS

| TYPE | ØA | ØB | C | D | Es.1 | Es.2 | Es.3 | (1) OR | (2) BK | (3) OR | ØF | ØG |
|------|---------|----|------|------|------|------|------|--------|--------|--------|----|------|
| 14 | M17x1 | 10 | 8.5 | 44.5 | 22 | 17 | 4 | 106 | 106 | 2056 | 26 | 17.5 |
| 38 | M18x1 | 11 | 8.5 | 45.5 | 24 | 17 | 5 | 2031 | 2031 | 2062 | 28 | 18.5 |
| 12 | M22x1.5 | 14 | 13.5 | 66.5 | 27 | 19 | 7 | 2043 | 2043 | 2075 | 33 | 22.5 |
| 34 | M27x1.5 | 18 | 18 | 82 | 32 | 22 | 9 | 2056 | 2056 | 3093 | 35 | 28 |

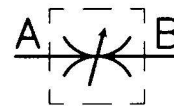

DOUBLE-ACTING BRAKING VALVES

They are composed of a needle throttling which allows a very sensitive control. They can be used in the assembling in manifolds and integrated blocks and are also used as cylinder braking valves.

Recommended filtration: 60 micron or inferior.

Max. working pressure: 300 bar

On request

Version in AISI 316 code FT 2243/2



FT 243/2

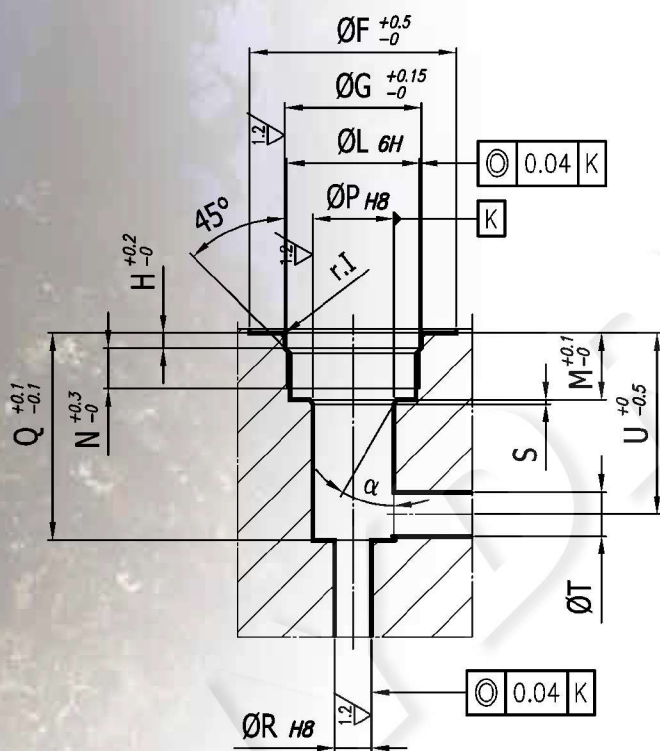

DIMENSIONS

| TYPE | H | ØL | M | N | ØP | Q | ØR | S | ØT | U | R.I | α° |
|------|-----|---------|----|-----|----|------|----|-----|-----|------|-----|-----|
| 14 | 2 | M17x1 | 9 | 5.5 | 10 | 28 | 4 | 0.6 | 4.5 | 25 | 0.3 | 30° |
| 38 | 2 | M18x1 | 9 | 5 | 11 | 28 | 5 | 0.6 | 6 | 24.5 | 0.3 | 30° |
| 12 | 2.5 | M22x1.5 | 15 | 10 | 14 | 40.5 | 8 | 1 | 8 | 36 | 0.3 | 20° |
| 34 | 3.5 | M27x1.5 | 21 | 15 | 18 | 54.5 | 10 | 1.5 | 10 | 48.5 | 0.5 | 20° |

FT 243/2 - 14

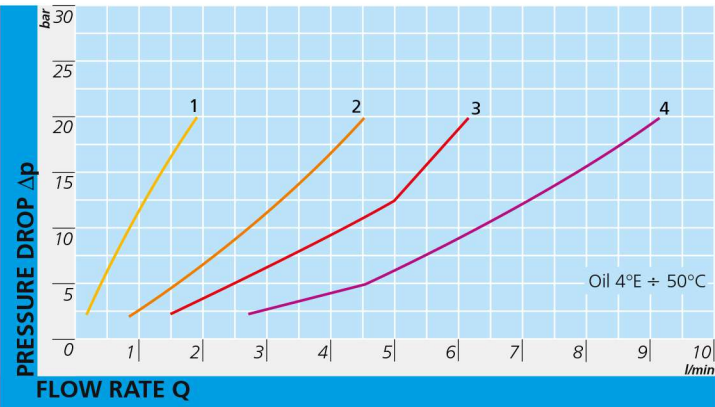

FT 243/2 - 38

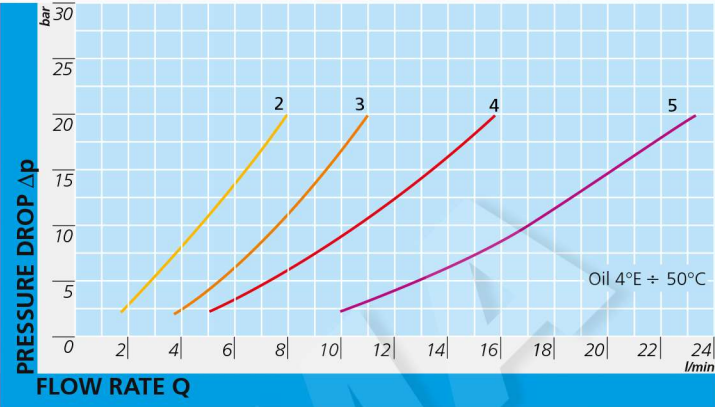

FLOW RATE CURVES

FT 243/2 - 12

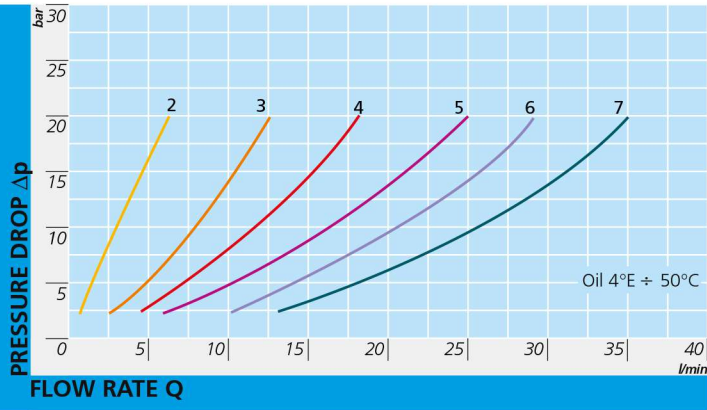

FT 243/2 - 34

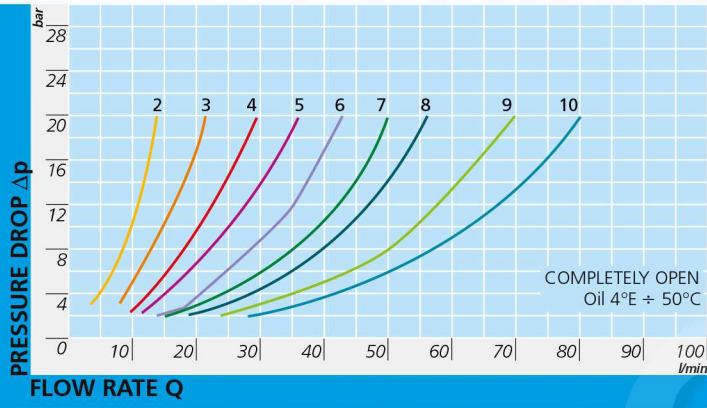

FT 243/2

