

Part number:

HYDROMA

HYDRAULICKÉ SYSTÉMY

**HIDROMA
SYSTEMS**

UKŁADY HYDRAULICZNE

HYDROMA

ГИДРАВЛИЧЕСКИЕ СИСТЕМЫ

Plate PRESSURE COMPENSATED single-acting flow control valves

FT 289/5

Compensated single-acting flow control valves available in sizes 03 and 60. Max. working pressure 250 Bar, adjustable oil flow rate from 3 to 20 Lt./min.

Plate mounted valves

Pressure compensated single-acting control

Carbon steel

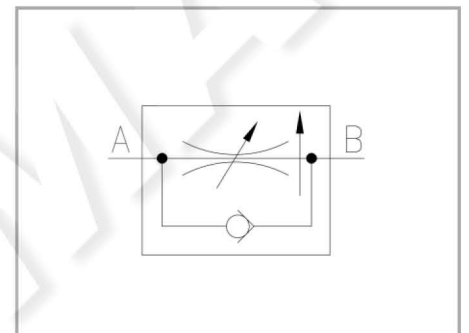

Technical information

Technical description

They are the "single-acting" version of the valve series FT 289/2 of which the main characteristics are maintained. They are provided with plate connections mod. CETOP 03 or interchangeable with the widely used valves (kind 60). The connection O-rings are equipped in series. Max. working pressure 250 bar.

Materials

CORPO VALVOLA / BODY VALVE	Acciaio/Steel 11 S Mn Pb 37-UNI EN 10087
ORGANI DI REGOLAZIONE / ADJUSTING COMPONENTS	Acciaio/Steel 35 S Mn Pb 10-UNI EN 10087
PISTONE COMPENSATORE / COMPENSATION PISTON	Acciaio/Steel 39 Ni Cr Mo 3-UNI EN 10083
GUARNIZIONI / GASKETS	Di serie NBR - A richiesta FPM/Standard NBR-on demand FPM
ANELLI ANTIESTRUSIONE / ANTIEXTRUSION RINGS	PTFE
GUIDA SFERA / BALL GUIDE	NYLON 66 + FIBRA CARBONIO / CARBON FIBRE
SFERA / BALL	Acciaio/Steel UNI 100-C 6
MOLLA / SPRING	Acciaio/Steel AISI 302
MANOPOLA TIPO MA / KNOB TYPE MA	Alluminio/Aluminum GD AISi12- UNI EN AB 46100

Technical data

TIPO / TYPE	PRESSIONE ESERCIZIO BAR / WORKING PRESSURE BAR	TEMPERATURA ESERCIZIO / WORKING TEMPERATURE	GRADO DI FILTRAZIONE μm / FILTRATION GRADE μm
03	250	-20°C/+100°C	25
60	250	-20°C/+100°C	25

Dimensional tables and drawings

TIPO / TYPE	A	B	C	D	E	$\varnothing F$	G	H	L	M
03	81	45	57	121	125,5	33	8,5	40,5	31,75	31
60	84	45	57	124	128,5	33	8,5	40,5	31,75	31

TIPO / TYPE	N	P	$\varnothing Q$	$\varnothing R$	S	T	OR	VITI / SCREWS	PESO / WEIGHT KG
03	12,7	30,2	5	12,5	15,5	0,75	2037	M5x85	1,490
60	10	33	6	17,2	15,5	0,75	2056	M5x90	1,530

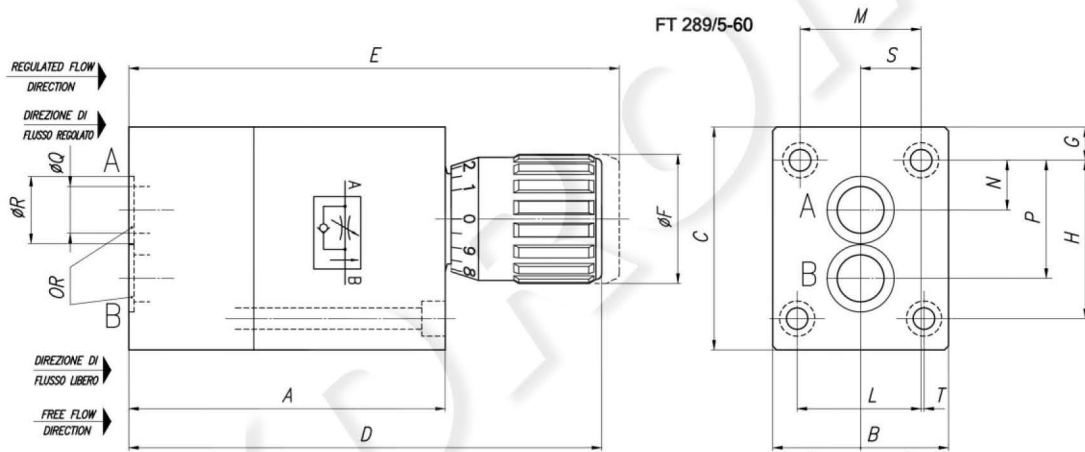
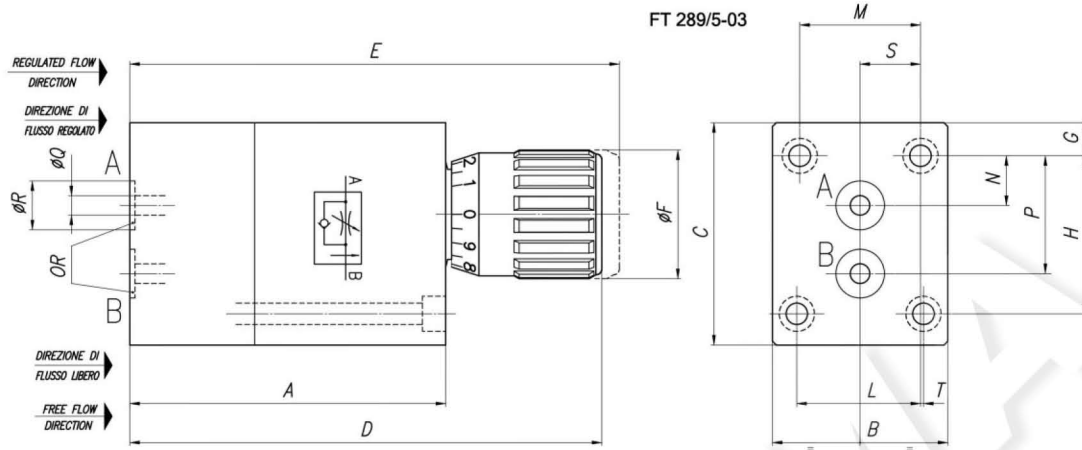

Flow rate curves

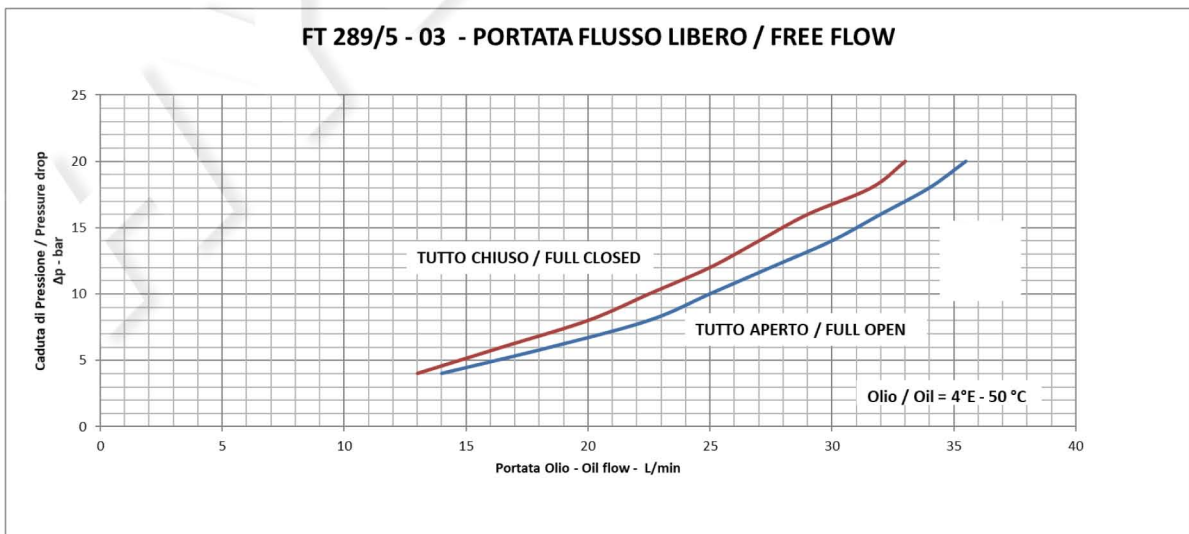
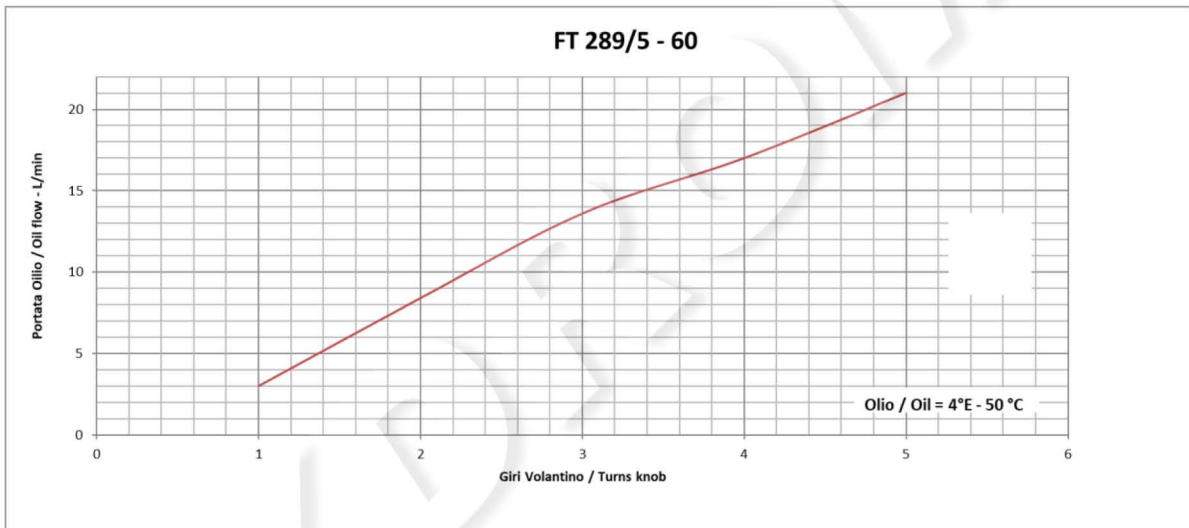
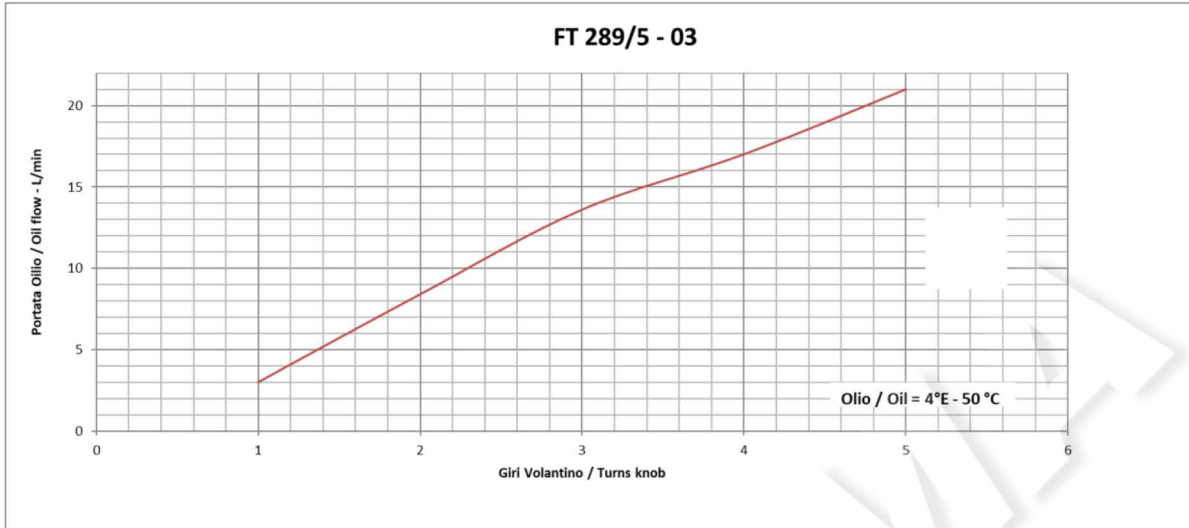

FT 289/5 - 60 - PORTATA FLUSSO LIBERO / FREE FLOW



FT 289/5 - 03

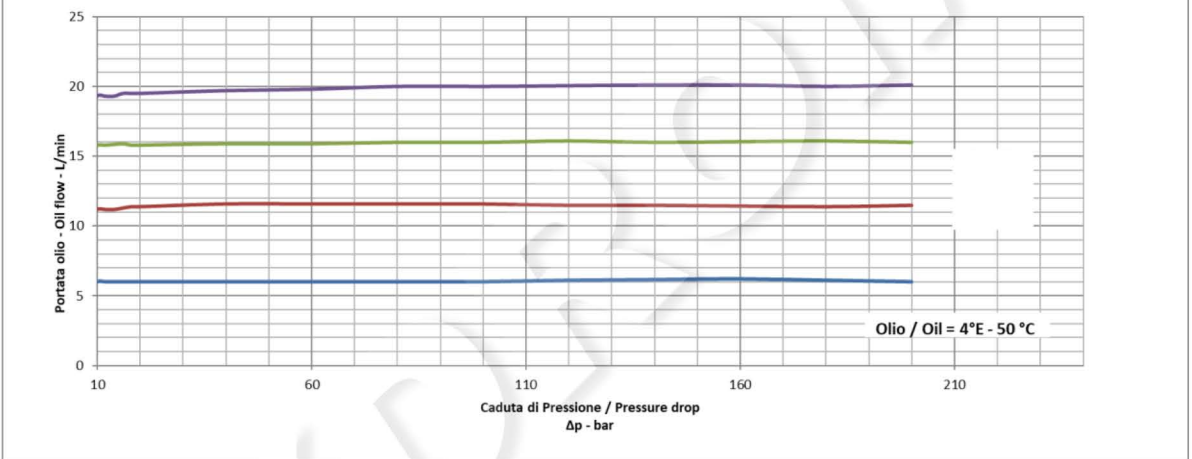

FT 289/5 - 60

