

Part number:

HYDROMA

HYDRAULICKÉ SYSTÉMY

**HIDROMA
SISTEMS**

UKŁADY HYDRAULICZNE

HYDROMA

ГИДРАВЛИЧЕСКИЕ СИСТЕМЫ

0.25 - 0.5



Filetti M10x1 profondità utile 9 mm.
Filetti G1/4 profondità utile 9 mm.

M10x1 threads depth 9 mm.
G1/4 threads depth 9 mm.

OPZIONI

"KK": sono presenti anche le porte di aspirazione e mandata D sul corpo come nella corrispondente versione standard.

OPTIONS

"KK": also D inlet and outlet ports are present on the body, as well as on the correspondent standard version.

MANDATA
OUTLET

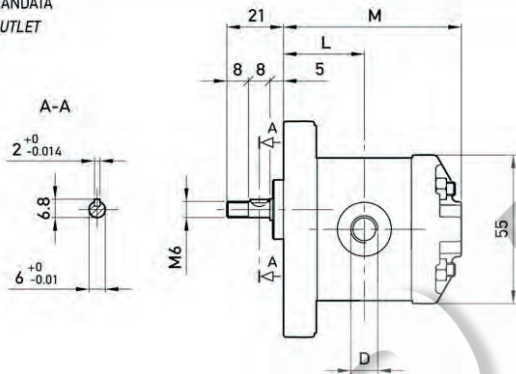

ASPIRAZIONE
INLET

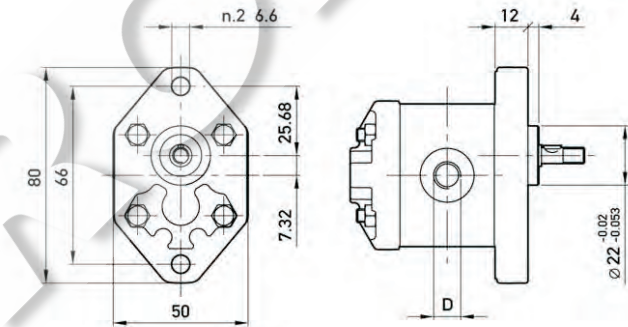

Opzioni:
Continuati

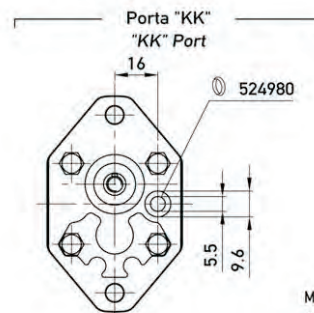
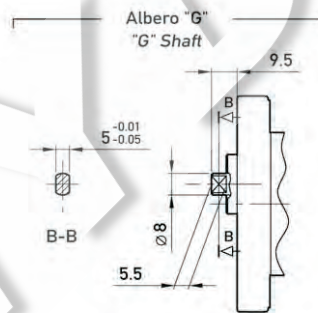

MANDATA
OUTLET

TIPO TYPE	CILINDRATA DISPLACEMENT	PORTATA a 1500 giri/min FLOW at 1500 rev/min	PRESSIONI MASSIME MAX PRESSURE			VELOCITÀ MASSIMA MAX SPEED	DIMENSIONI DIMENSIONS		
			P ₁	P ₂	P ₃		M	L	D
	cm ³ /rev [in ³ /rev]	lit/min [gpm/min]	bar	bar	bar	rpm/min [rpm]	mm	mm	
0.25 D 18	0,19	0,29	190	210	230	7000	54	24	M10x1
0.25 D 24	0,26	0,38	190	210	230	7000	55	24,5	M10x1
0.25 D 30	0,32	0,48	190	210	230	7000	56	25	M10x1
0.25 D 36	0,38	0,58	190	210	230	7000	57	25,5	M10x1
0.25 D 48	0,51	0,77	190	210	230	7000	59	26,5	M10x1
0.25 D 60	0,64	0,96	190	210	230	7000	61	27,5	M10x1
0.5 D 0,50	0,50	0,75	190	210	230	7000	63	28,5	G1/4
0.5 D 0,75	0,63	0,94	190	210	230	7000	64	29	G1/4
0.5 D 1,00	0,88	1,31	190	210	230	7000	66	30	G1/4
0.5 D 1,30	1,00	1,50	190	210	230	6000	67	30,5	G1/4
0.5 D 1,60	1,25	1,88	190	210	230	5000	69	31,5	G1/4
0.5 D 2,00	1,50	2,25	190	210	230	4000	71	32,5	G1/4

0.25 KA - 0.5 KA

Filetto G1/8 profondità utile 8 mm.
Filetto G1/4 profondità utile 12 mm.

G1/8 thread depth 8 mm.
G1/4 thread depth 12 mm.



MANDATA
OUTLET

ASPIRAZIONE
INLET

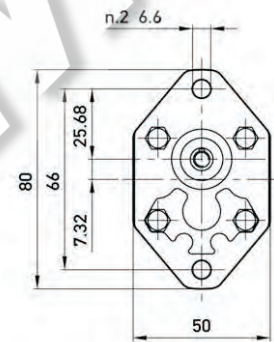
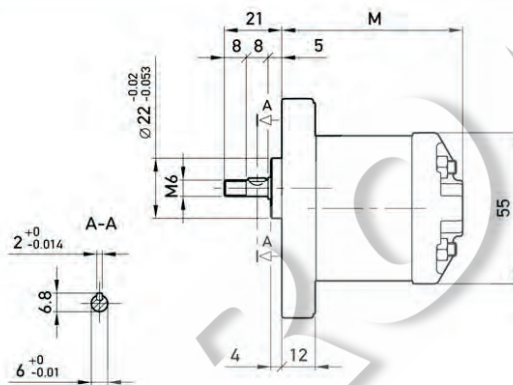
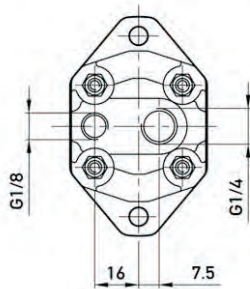

Opzioni:
Opzioni

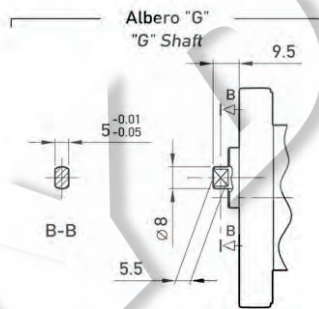

TIPO TYPE	CILINDRATA DISPLACEMENT	PORTATA a 1500 giri/min FLOW at 1500 rev/min	PRESSIONI MASSIME MAX PRESSURE			VELOCITÀ MASSIMA MAX SPEED	DIMENSIONI DIMENSIONS
			P ₁	P ₂	P ₃		
	cm ³ /giri (cm ³ /rev)	litri/min (liters/min)	bar	bar	bar	giri/min (rpm)	mm
0.25 D 18 KA	0,19	0,29	190	210	230	7000	54
0.25 D 24 KA	0,26	0,38	190	210	230	7000	55
0.25 D 30 KA	0,32	0,48	190	210	230	7000	56
0.25 D 36 KA	0,38	0,58	190	210	230	7000	57
0.25 D 48 KA	0,51	0,77	190	210	230	7000	59
0.25 D 60 KA	0,64	0,96	190	210	230	7000	61
0.5 D 0,50 KA	0,50	0,75	190	210	230	7000	63
0.5 D 0,75 KA	0,63	0,94	190	210	230	7000	64
0.5 D 1,00 KA	0,88	1,31	190	210	230	7000	66
0.5 D 1,30 KA	1,00	1,50	190	210	230	6000	67
0.5 D 1,60 KA	1,25	1,88	190	210	230	5000	69
0.5 D 2,00 KA	1,50	2,25	190	210	230	4000	71

0.25 CURVE CARATTERISTICHE

0.25 PERFORMANCE CURVES

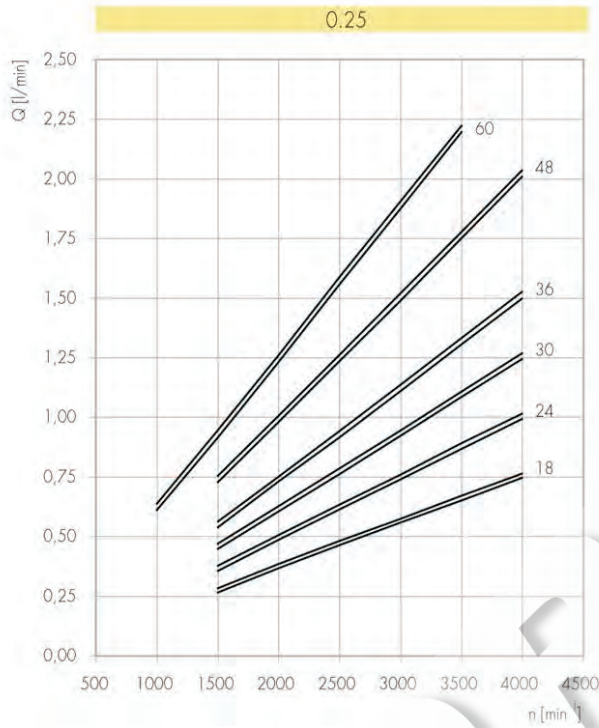

Le curve sono state ottenute alla temperatura di 50°C, utilizzando olio con viscosità 30 cSt alle pressioni sotto riportate.

Each curve has been obtained at 50°C, using oil with viscosity 30 cSt at these pressure.

18
24
30
36
48
60

25-230 bar

