

Part number:

HYDROMA

HYDRAULICKÉ SYSTÉMY

**HIDROMA
SYSTEMS**

UKŁADY HYDRAULICZNE

HYDROMA

ГИДРАВЛИЧЕСКИЕ СИСТЕМЫ

Manifolds

RE 18325-85/05.23

Replaces: 11.22

Standard manifolds common cavity
Standard manifolds special cavity
Manifolds with emergency screw
Manifolds with SUN cavity
Manifolds with Rexroth special cavity



General specifications

• Max operating pressure for steel body:	350 bar (5000 psi)
• Max operating pressure for high pressure steel body:	500 bar (7250 psi)
• Max operating pressure for aluminium body:	210 bar (3000 psi)

Note: aluminium bodies are often strong enough for operating pressures exceeding 210 bar (3000 psi), depending from the fatigue life expected in the specific application. If in doubt, consult our Service Network.

Standard manifolds - Common cavity Size 08 - Aluminium / Steel

CAVITY: CA-08A-3C
(DOUBLE CAVITY)

	Ordering code	Ports V1-V2-C1-C2	Weight kg (lbs)
Aluminium	OC1009185 R934000146	G 3/8	0.36 (0.79)
Steel	OC1009184 R934000145	G 3/8	1.00 (2.21)

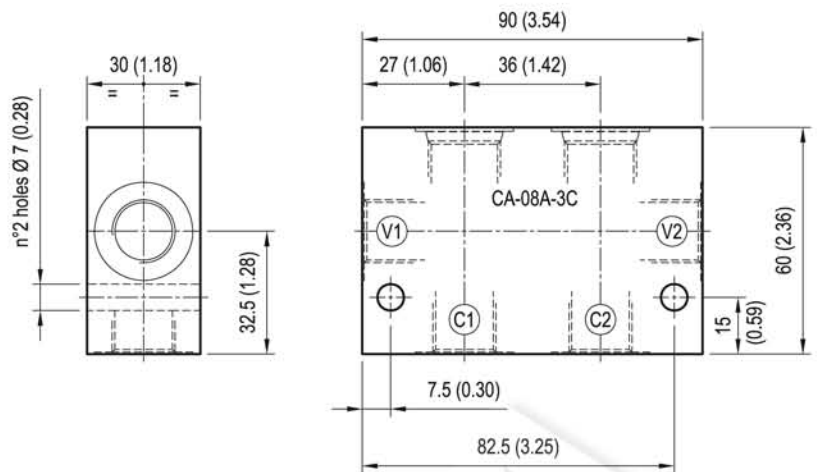

[mm / Inches]

CAVITY: CA-08A-3N

	Ordering code	Ports 1-2-3	Weight kg (lbs)
Aluminium	OC1009042 R901100471	G 1/4	0.30 (0.66)
	OC1009048 R901100497	G 3/8	0.27 (0.60)
Steel	OC1009225 R934000186	G 1/4	0.78 (1.72)
	OC1009153 R934000140	G 3/8	0.74 (1.63)

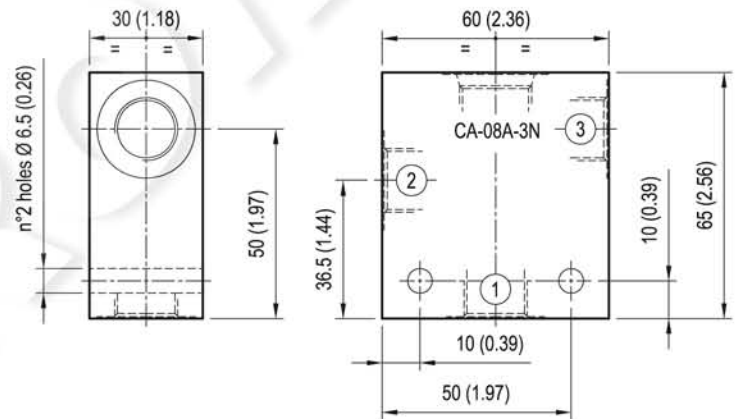

[mm / Inches]

CAVITY: CA-08A-4N

	Ordering code	Ports 1-2-3-4	Weight kg (lbs)
Aluminium	OC1009047 R901100531	G 1/4	0.33 (0.73)
	OC1009046 R901100524	G 3/8	0.29 (0.64)
Steel	OC1009236 R934000197	G 1/4	0.93 (2.05)
	OC1009237 R934000198	G 3/8	0.81 (1.79)

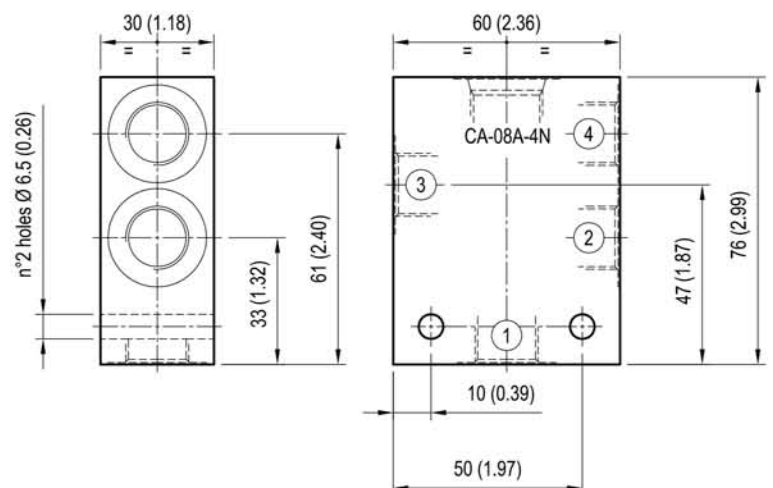

[mm / Inches]