

Part number:

066-10025**HYDROMA**

HYDRAULICKÉ SYSTÉMY

**HIDROMA
SYSTEMS**











UKŁADY HYDRAULICZNE

HYDROMA

ГИДРАВЛИЧЕСКИЕ СИСТЕМЫ

LUBRIFICAZIONE
LUBRICATION
LUBRIFICATION
SCHMIERUNG

Quantita' di lubrificante con-
tenuto nei riduttori [l]Lubricant quantity inside the
planetary drives [l]Quantité de lubrifiant dans
les réducteurs [l]Fuellmenge Getriebeschmie-
rung [l]

	M		P		CPC		F		FS	
										
PG 101	0.5	1.0	0.5	1.0	0.8	1.6	0.5	1.0	0.5	1.0
PG 102	0.7	1.4	0.7	1.4	1.0	2.0	0.7	1.4	0.7	1.4
PG 103	0.9	1.8	0.9	1.8	1.2	2.4	0.9	1.8	0.9	1.8
PG 104	1.1	2.2	1.1	2.2	1.4	2.8	1.1	2.2	1.1	2.2
PGA 102	2	4	2	4	2.3	4.6	2.0	4.0	2.0	4.0
PGA 103	2.2	4.4	2.2	4.4	2.5	5.0	2.2	4.4	2.2	4.4
PGA 104	2.4	4.8	2.4	4.8	2.7	5.4	2.4	4.8	2.4	4.8
PG 161	0.6	1.2	0.6	1.2	0.9	1.8	0.6	1.2	0.6	1.2
PG 162	0.8	1.6	0.8	1.6	1.1	2.2	0.8	1.6	0.8	1.6
PG 163	1.0	2.0	1.0	2.0	1.3	2.6	1.0	2.0	1.0	2.0
PG 164	1.2	2.4	1.2	2.4	1.5	3.0	1.2	2.4	1.2	2.4
PGA 162	2.1	4.2	2.1	4.2	2.4	4.8	2.1	4.2	2.1	4.2
PGA 163	2.3	4.6	2.3	4.6	2.6	5.2	2.3	4.6	2.3	4.6
PGA 164	2.5	5.0	2.5	5.0	2.8	5.6	2.5	5.0	2.5	5.0
PG 251	1.0	2.0	1.2	2.4	1.5	3.0	0.8	1.6	1.0	2.0
PG 252	1.3	2.6	1.5	3.0	1.8	3.6	1.1	2.2	1.3	2.6
PG 253	1.5	3.0	1.7	3.4	2.0	4.0	1.3	2.6	1.5	3.0
PG 254	1.7	3.4	1.9	3.8	2.2	4.4	1.5	3.0	1.5	3.0
PGA 252	2.6	5.2	3.8	7.6	3.1	6.2	2.4	4.8	2.6	5.2
PGA 253	2.8	5.6	3.0	6.0	3.3	6.6	2.6	5.2	2.8	5.6
PGA 254	3.0	6.0	3.2	6.4	3.5	7.0	2.8	5.6	3.0	6.0
PG 501	1.1	2.2	1.3	2.6	1.6	3.2	0.9	1.8	1.1	2.2
PG 502	1.5	3.0	1.7	3.4	2.0	4.0	1.3	2.6	1.5	3.0
PG 503	1.8	3.6	2.0	4.0	2.3	4.6	1.6	3.2	1.8	3.6
PG 504	2.0	4.0	2.2	4.4	2.5	5.0	1.8	3.6	2.0	4.0
PGA 502	3.1	6.2	3.3	6.6	3.6	7.2	2.9	5.8	3.1	6.2
PGA 503	3.2	6.4	3.4	6.8	3.7	7.4	3.3	6.6	3.2	6.4
PGA 504	3.3	6.6	3.5	7.0	3.8	7.6	3.1	6.2	3.3	6.6
PG 701	—	—	1.6	3.2	2.4	4.8	1.6	3.2	1.6	3.2
PG 702	—	—	2.0	4.0	2.8	5.6	2.0	4.0	2.0	4.0
PG 703	—	—	2.3	4.6	3.1	6.2	2.3	4.6	2.3	4.6
PG 704	—	—	2.5	5.0	3.3	6.6	2.5	5.0	2.5	5.0
PGA 702	—	—	3.6	7.2	4.4	8.8	3.6	7.2	3.6	7.2
PGA 703	—	—	3.8	7.6	4.6	9.2	3.8	7.6	3.8	7.6
PGA 704	—	—	4.0	8.0	4.8	9.6	4.0	8.0	4.0	8.0
PG 1001	2.4	4.8	—	—	3.6	7.2	2.2	4.4	2.4	4.8
PG 1002	3.1	6.2	—	—	4.3	8.6	2.9	5.8	3.1	6.2
PG 1003	3.5	7.0	—	—	4.7	9.4	3.3	6.6	3.5	7.0
PG 1004	3.8	7.6	—	—	5.0	10.0	3.6	7.2	3.8	7.6
PGA 1002	4.4	8.8	—	—	5.6	11.2	4.2	8.4	4.4	8.8
PGA 1003	5.1	10.2	—	—	6.3	12.6	4.9	9.8	5.1	10.2
PGA 1004	6.5	13.0	—	—	7.7	15.4	5.5	11.0	6.5	13.0

NB. Le quantità di lubrificante riportate sono indicative e vanno controllate in fase di riempimento verificando il livello tramite l'apposito tappo di servizio











NB. The lubricant quantities shown in the table are advisable, but we recommend to check them during the filling operation, referring to the level plug.

N.B. Le quantité de lubrifiant marquée est à titre indicatif et doit être contrôlée en phase de remplissage en vérifiant le niveau par le bouchon de niveau.

P.S. Die angegebenen Schmiermittelmengen sind indikativ und sind während der Befüllung anhand der Oelstandstopfen zu ueberpruefen.











**LUBRIFICAZIONE
LUBRICATION
LUBRIFICATION
SCHMIERUNG**

Quantita' di lubrificante contenuto nei riduttori [l] Lubricant quantity inside the planetary drives [l] Quantité de lubrifiant dans les réducteurs [l] Fuellmenge Getriebeschmierung [l]

	M		P		CPC		F		FS	
										
PG 1601	2.6	5.2	4.3	8.6	3.9	7.8	1.9	3.8	2.6	5.2
PG 1602	3.3	6.6	5.0	10.0	4.6	9.2	2.6	5.2	3.3	6.6
PG 1603	3.7	7.4	5.4	10.8	5.0	10.0	3.0	6.0	3.7	7.4
PG 1604	4.0	8.0	5.7	11.4	5.3	10.6	3.3	6.6	4.0	8.0
PGA 1602	4.6	9.2	6.3	12.6	5.9	11.8	3.9	7.8	4.6	9.2
PGA 1603	5.3	10.6	7.0	14.0	6.6	13.2	4.6	9.2	5.3	10.6
PGA 1604	6.5	13.0	7.3	14.6	7.8	15.6	5.8	11.6	6.5	13.0
PG 1802	3.9	7.8	5.6	11.2	5.2	10.4	3.2	6.4	3.9	7.8
PG 1803	4.6	9.2	6.3	12.6	5.9	11.8	3.9	7.8	4.6	9.2
PG 1804	4.9	9.8	6.6	13.2	6.2	12.4	4.2	8.4	4.9	9.8
PGA 1802	5.6	11.2	7.3	14.6	6.9	13.8	4.9	9.8	5.6	11.2
PGA 1803	5.9	11.8	7.6	15.2	7.2	14.4	5.2	10.4	5.9	11.8
PGA 1804	6.6	13.2	8.3	16.6	7.9	15.8	5.9	11.8	6.6	13.2
PG 2501	3.7	7.4	—	—	3.7	7.4	2.9	5.8	2.9	5.8
PG 2502	4.6	9.2	—	—	4.6	9.2	3.8	7.6	3.8	7.6
PG 2503	5.0	10.0	—	—	5.0	10.0	4.2	8.4	4.2	8.4
PG 2504	5.3	10.6	—	—	5.3	10.6	4.5	9.0	4.5	9.0
PGA 2502	9.1	18.2	—	—	9.1	18.2	8.3	16.6	8.3	16.6
PGA 2503	6.6	13.2	—	—	6.6	13.2	5.8	11.6	5.8	11.6
PGA 2504	7.0	14.0	—	—	7.0	14.0	6.2	12.4	6.2	12.4
PG 3002	5.3	10.6	—	—	5.3	10.6	4.5	9.0	4.5	9.0
PG 3003	5.8	11.6	—	—	5.8	11.6	5.0	10.0	5.0	10.0
PG 3004	6.1	12.2	—	—	6.1	12.2	5.3	10.6	5.3	10.6
PGA 3003	10.2	20.4	—	—	10.2	20.4	9.4	18.8	9.4	18.8
PGA3004	8.2	16.4	—	—	8.2	16.4	7.0	14.0	7.0	14.0
PG 3501	4.0	8.0	—	—	4.0	8.0	3.3	6.6	3.3	6.6
PG 3502	5.5	11.0	—	—	5.5	11.0	4.7	9.4	4.7	9.4
PG 3503	6.0	12.0	—	—	6.0	12.0	5.2	10.4	5.2	10.4
PG 3504	6.3	12.6	—	—	6.3	12.6	5.5	11.0	5.5	11.0
PGA 3502	6.7	13.4	—	—	6.7	13.4	5.8	11.6	5.8	11.6
PGA 3503	10.2	20.4	—	—	10.2	20.4	9.4	18.8	9.4	18.8
PGA 3504	8.2	16.4	—	—	8.2	16.4	7.0	14.0	7.0	14.0
PG 5001	5.2	10.4	—	—	5.2	10.4	4.5	9.0	4.5	9.0
PG 5002	6.5	13.0	—	—	6.5	13.0	5.8	11.6	5.8	11.6
PG 5003	7.1	14.2	—	—	7.1	14.2	6.4	12.8	6.4	12.8
PG 5004	7.5	15.0	—	—	7.5	15.0	6.9	13.8	6.9	13.8
PGA5002	11.0	22.0	—	—	11.0	22.0	10.3	20.6	10.3	20.6
PGA 5003	8.5	17.0	—	—	8.5	17.0	7.8	15.6	7.8	15.6
PGA 5004	9.1	18.2	—	—	9.1	18.2	8.4	16.8	8.4	16.8
PG 6501	7.2	14.4	—	—	7.2	14.4	6.2	12.4	6.2	12.4
PG 6502	8.5	17.0	—	—	8.5	17.0	7.5	15.0	7.5	15.0
PG 6503	9.7	19.4	—	—	9.7	19.4	8.7	17.4	8.7	17.4
PG 6504	10.1	20.2	—	—	10.1	20.2	9.1	18.2	9.1	18.2
PGA 6503	14.2	28.4	—	—	14.2	28.4	13.2	26.4	13.2	26.4
PGA 6504	11.7	23.4	—	—	11.7	23.4	10.7	21.4	10.7	21.4
PG 9001	8.7	17.4	—	—	8.7	17.4	8.7	17.4	8.7	17.4
PG 9002	10.0	20.0	—	—	10.0	20.0	10.0	20.0	10.0	20.0
PG 9003	11.2	22.4	—	—	11.2	22.4	11.2	22.4	11.2	22.4
PG 9004	11.6	23.2	—	—	11.6	23.2	11.6	23.2	11.6	23.2
PGA 9003	15.7	31.4	—	—	15.7	31.4	15.7	31.4	15.7	31.4
PGA 9004	13.2	26.4	—	—	13.2	26.4	13.2	26.4	13.2	26.4

**LUBRIFICAZIONE
LUBRICATION
LUBRIFICATION
SCHMIERUNG**

Quantita' di lubrificante contenuto nei riduttori [l] Lubricant quantity inside the planetary drives [l] Quantité de lubrifiant dans les réducteurs [l] Fuellmenge Getriebeschmierung [l]

	M		P		CPC		F		FS	
										
PG 14001	15.0	—	—	—	—	—	16.4	—	16.4	—
PG 14002	16.4	32.8	—	—	—	—	16.4	32.8	16.4	32.8
PG 14003	17.6	35.2	—	—	—	—	17.6	35.2	17.6	35.2
PG 14004	18.1	36.2	—	—	—	—	18.1	36.2	18.1	36.2
PG 14005	18.4	36.8	—	—	—	—	18.4	36.8	18.4	36.8
PGA 14004	20.6	41.2	—	—	—	—	20.6	41.2	20.6	41.2
PGA 14005	20.1	40.2	—	—	—	—	20.1	40.2	20.1	40.2
PG 180001	21.0	—	—	—	—	—	21.0	—	21.0	—
PG 18002	23.4	46.8	—	—	—	—	23.4	46.8	23.4	46.8
PG 18003	24.8	49.6	—	—	—	—	24.8	49.6	24.8	49.6
PG 18004	25.2	50.4	—	—	—	—	25.2	50.4	25.2	50.4
PG 18005	25.5	51.0	—	—	—	—	25.5	51.0	25.5	51.0
PGA 18003	26.4	52.8	—	—	—	—	26.4	52.8	26.4	52.8
PGA 18004	27.8	55.6	—	—	—	—	27.8	55.6	27.8	55.6
PGA 18005	27.2	54.4	—	—	—	—	27.2	54.4	27.2	54.4
PG 22001	21.0	—	—	—	—	—	21.0	—	21.0	—
PG 22002	23.4	46.8	—	—	—	—	23.4	46.8	23.4	46.8
PG 22003	24.8	49.6	—	—	—	—	24.8	49.6	24.8	49.6
PG 22004	25.2	50.4	—	—	—	—	25.2	50.4	25.2	50.4
PG 22005	25.5	51.0	—	—	—	—	25.5	51.0	25.5	51.0
PGA 22003	26.4	52.8	—	—	—	—	26.4	52.8	26.4	52.8
PGA 22004	27.8	55.6	—	—	—	—	27.8	55.6	27.8	55.6
PGA 22005	27.2	54.4	—	—	—	—	27.2	54.4	27.2	54.4
PG 33001	42.5	—	—	—	—	—	42.5	—	42.5	—
PG 33002	46.5	93.0	—	—	—	—	46.5	93.0	46.5	93.0
PG 33003	47.9	95.8	—	—	—	—	47.9	95.8	47.9	95.8
PG 33004	48.7	97.4	—	—	—	—	48.7	97.4	48.7	97.4
PG 33005	49.1	98.2	—	—	—	—	49.1	98.2	49.1	98.2
PGA 33004	50.9	101.8	—	—	—	—	50.9	101.8	50.9	101.8
PGA 33005	50.7	101.4	—	—	—	—	50.7	101.4	50.7	101.4
PG 40001	42.5	—	—	—	—	—	42.5	—	42.5	—
PG 40002	46.5	93.0	—	—	—	—	46.5	93.0	46.5	93.0
PG 40003	47.9	95.8	—	—	—	—	47.9	95.8	47.9	95.8
PG 40004	48.7	97.4	—	—	—	—	48.7	97.4	48.7	97.4
PG 40005	49.1	98.2	—	—	—	—	49.1	98.2	49.1	98.2
PGA 40004	50.9	101.8	—	—	—	—	50.9	101.8	50.9	101.8
PGA 40005	50.7	101.4	—	—	—	—	50.7	101.4	50.7	101.4
PG 55001	50.0	—	—	—	—	—	50.0	—	50.0	—
PG 55002	60.0	120.0	—	—	—	—	60.0	120.0	60.0	120.0
PG 55003	62.5	125.0	—	—	—	—	62.5	125.0	62.5	125.0
PG 55004	63.5	127.0	—	—	—	—	63.5	127.0	63.5	127.0
PG 55005	64.0	128.0	—	—	—	—	64.0	128.0	64.0	128.0
PGA 55004	65.5	131.0	—	—	—	—	65.5	131.0	65.5	131.0
PGA 55005	66.5	133.0	—	—	—	—	66.5	133.0	66.5	133.0
PG 65001	50.0	—	—	—	—	—	60.0	—	50.0	—
PG 65002	60.0	120.0	—	—	—	—	60.0	120.0	60.0	120.0
PG 65003	62.5	125.0	—	—	—	—	62.5	125.0	62.5	125.0
PG 65004	63.5	127.0	—	—	—	—	63.5	127.0	63.5	127.0
PG 65005	64.0	128.0	—	—	—	—	64.0	128.0	64.0	128.0
PGA 65005	65.5	131.0	—	—	—	—	65.5	131.0	65.5	131.0

**LUBRIFICAZIONE
LUBRICATION
LUBRIFICATION
SCHMIERUNG**

Vaso di espansione

Expansion tank

Vase d'expansion

Ausgleichsbehälter

Per applicazioni dove vengono considerate posizioni di montaggio verticali si consiglia l'utilizzo di un vaso di espansione che permette di alloggiare eventuali espansioni di olio o di garantire un rabbocco in posizioni inaccessibili. Tale accessorio può essere fornito su richiesta.

For applications with planetary gearboxes mounted in vertical position, we suggest the use of an oil reservoir which can absorb eventual oil expansions and/or ensure a safe topping up in accessible positions. This fitting is supplied upon specific request.

Pour les applications où nous devons considérer les positions de montage verticales nous conseillons l'utilisation d'un vase d'expansion qui permet une éventuelle expansion de l'huile ou qui garanti un remplissage dans des positions inaccessibles. Cet accessoire peut être fourni sur demande.

Fuer die vertikalen Einbaupositionen ist die Ausrüstung mit einem Oelausgleichsbehälter zu empfehlen. Dadurch ist gegeben, dass eventuelle Oelüberträge vermieden und eine einfache Befüllung ermöglicht wird. Der Behälter ist auf Nachfrage lieferbar.

Spurgo aria e livello olio effettivo nel riduttore
Air drain and oil level in the gearbox
Reniflard et niveau d'huile dans le réducteur
Entlüften und Ölstand

Carico e sfiato
Filling and breathing
Remplissage à évent
Einfüllen und Entlüften

Livello
Level
Niveau
Ölstand

Vaso di espansione
Expansion tank
Reservoir d'huile
Ausgleichsbehälter

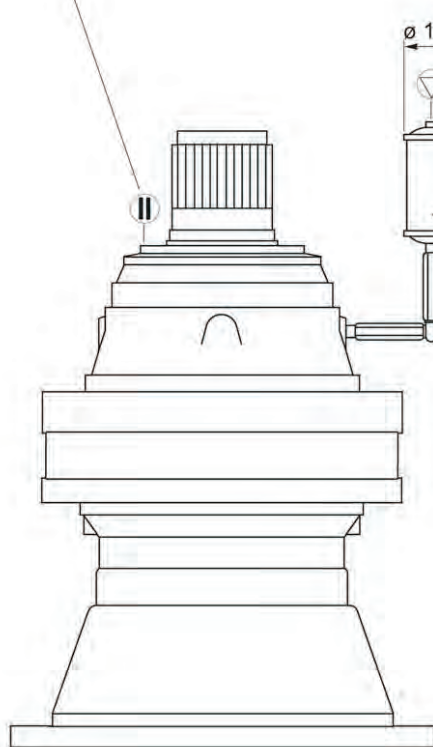
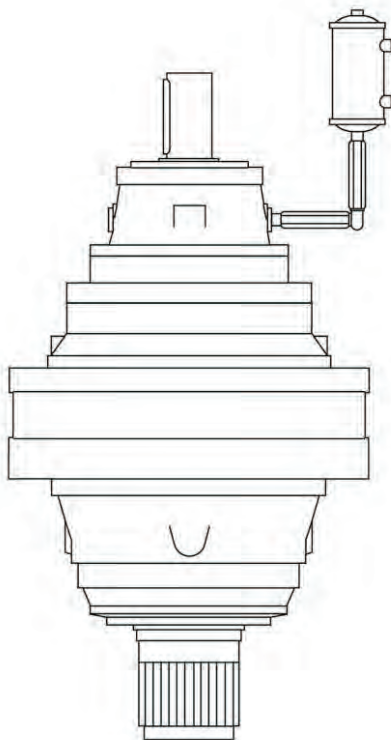

ø 102

246

LUBRIFICAZIONE
LUBRICATION
LUBRIFCATION
SCHMIERUNG

Posizioni di montaggio

Mounting positions

Positions de montage

Einbauposition

M-P

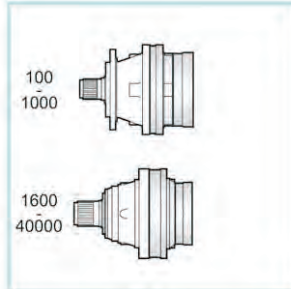

B5

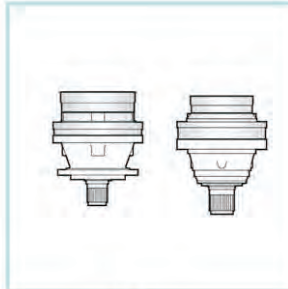

V1

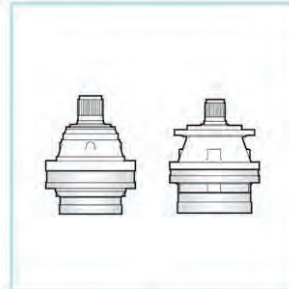

V3

F

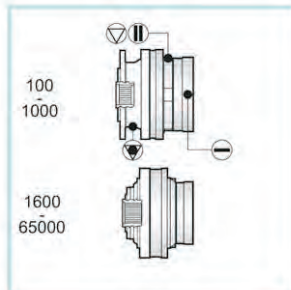

B5

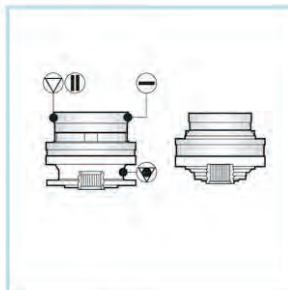

V1

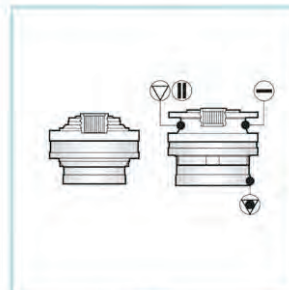

V3

FS

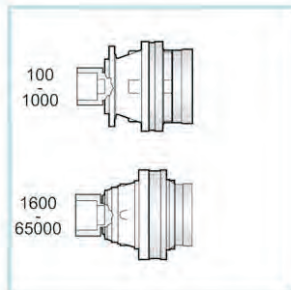

B5

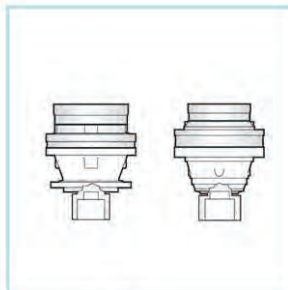

V1

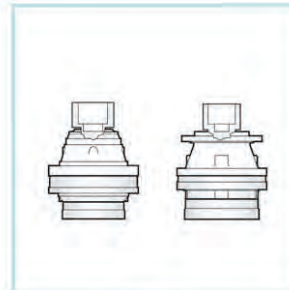

V3

CPC

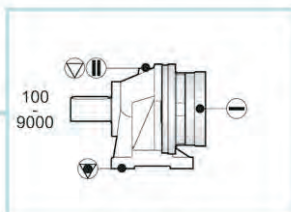

B3

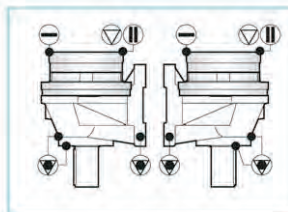

V2

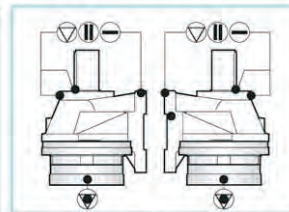

V4

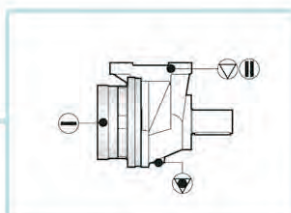

B4

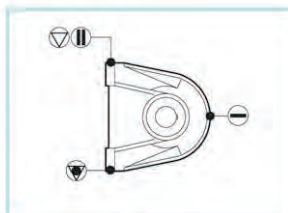

B6

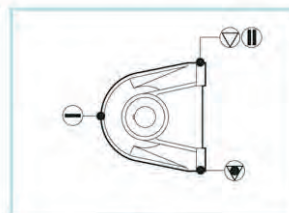

B7

Tappi olio
Oil plugs
Bouchons huile
Ölstopfen

II Tappo sfiato
Vent plug
Bouchon à évent
Entlüftungstopfen

V Tappo carico
Filling plug
Bouchon remplissage
Einfüllstopfen

— Tappo livello
Level plug
Bouchon jauge
Ölstandstopfen

▽ Tappo scarico
Drain plug
Bouchon vidange
Ablasstopfen

N.B.

L'orientamento della foratura della flangia di fissaggio è come illustrato nelle schede dei dati dimensionali dei riduttori (pag. 44-196).

The mounting flange orientation is shown in each planetary gears technical sheets (page 44-196).

L'orientation de la flasque de montage est indiquée dans chaque fiche technique réducteur (page 44-196).

Die Ausföhrung der Befestigungsvorrichtung (Flansch, Bohrung) ist in den Datenblaettern der Getriebe auf den Seiten 44-196 ersichtlich.

LUBRIFICAZIONE
LUBRICATION
LUBRIFICATION
SCHMIERUNG

Posizioni di montaggio

Mounting positions

Positions de montage

Einbauposition

M-P

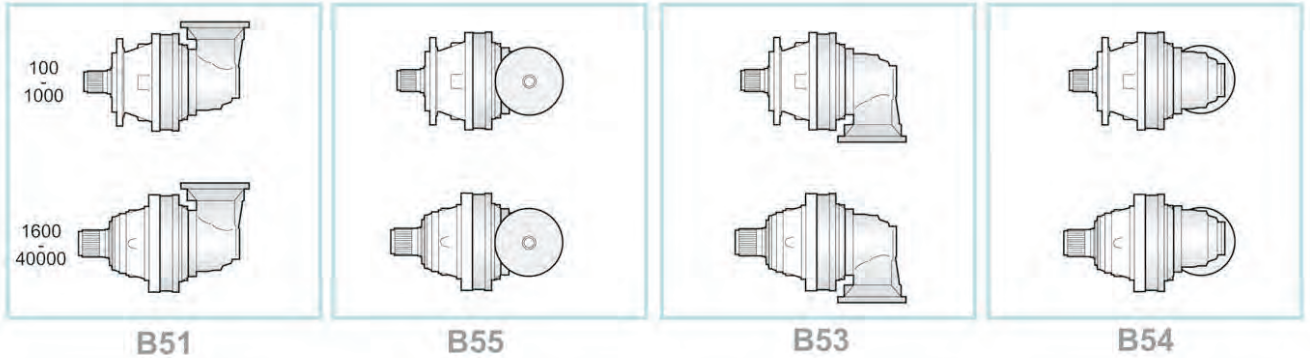

F

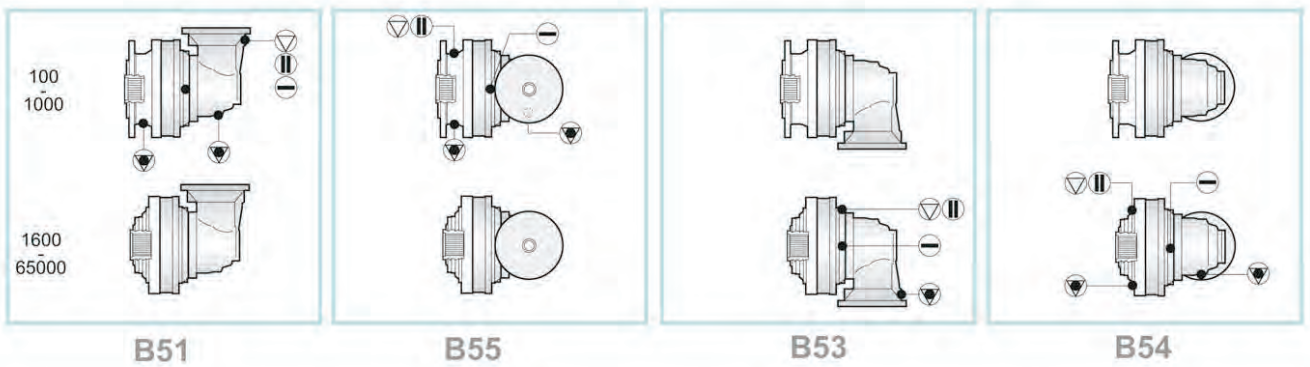

FS

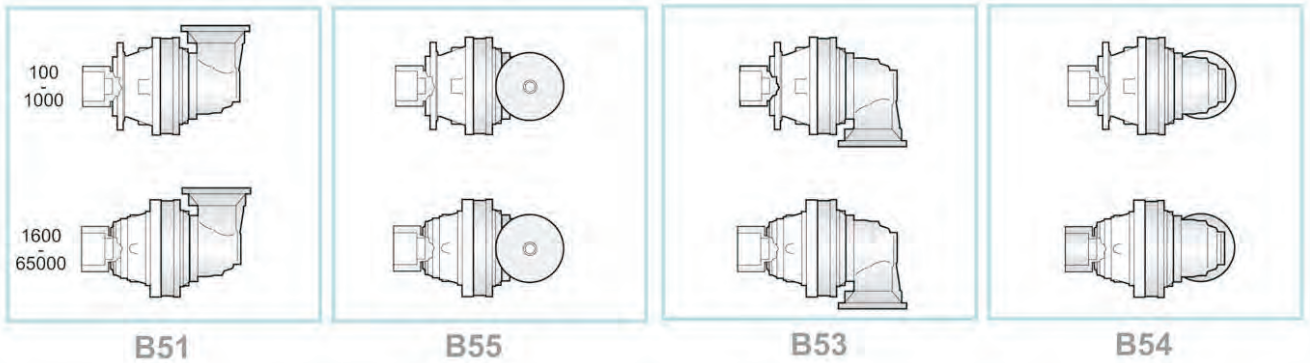

CPC

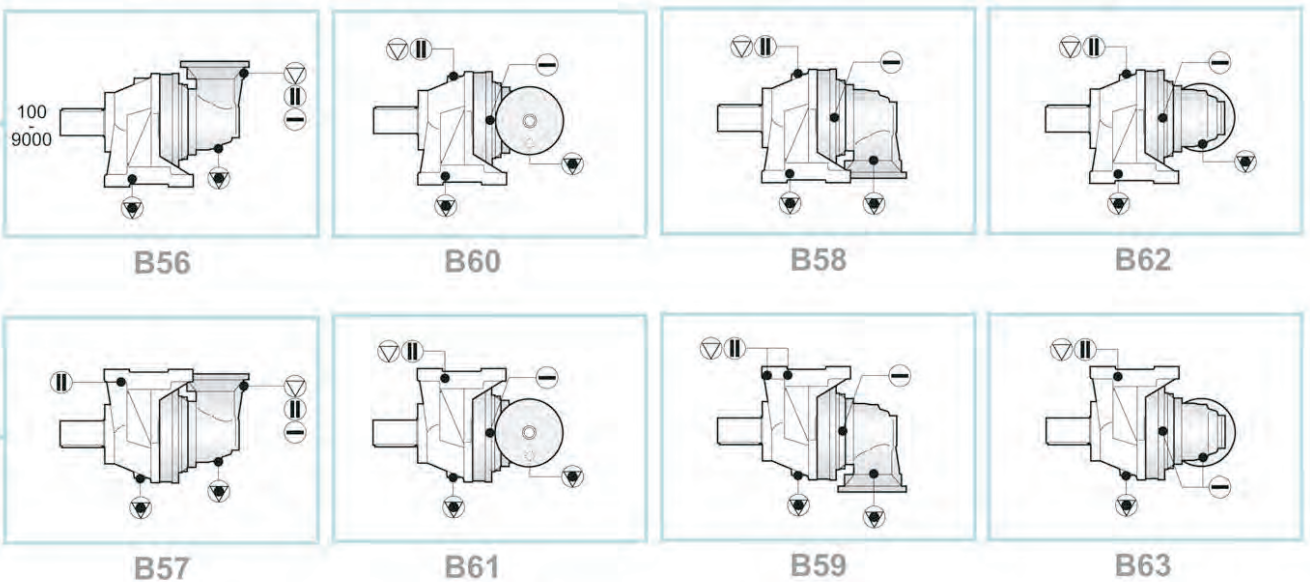

LUBRIFICAZIONE
LUBRICATION
LUBRIFICATION
SCHMIERUNG

Posizioni di montaggio

Mounting positions

Positions de montage

Einbauposition

M-P

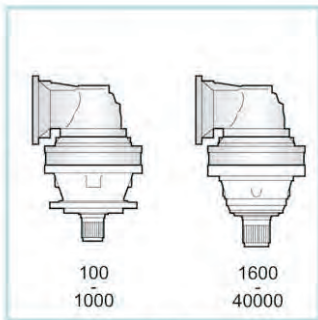

V15

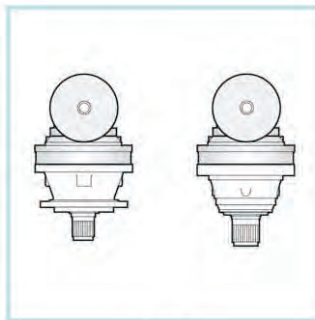

V16

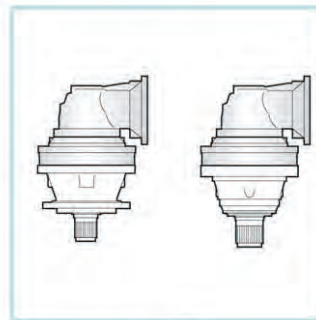

V17

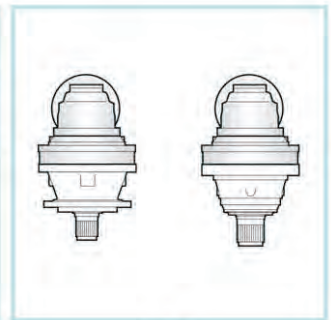

V18

F

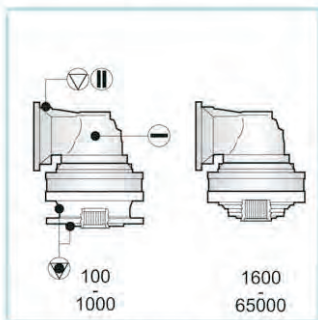

V15

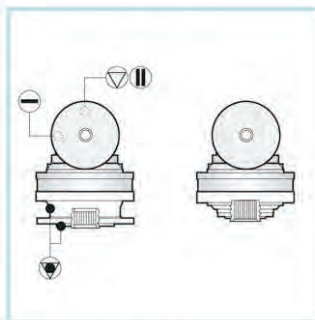

V16

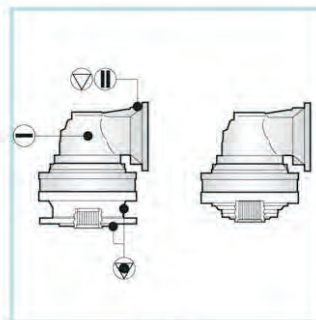

V17

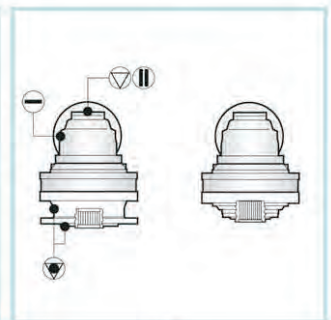

V18

FS

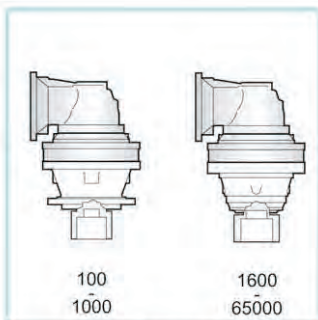

V15

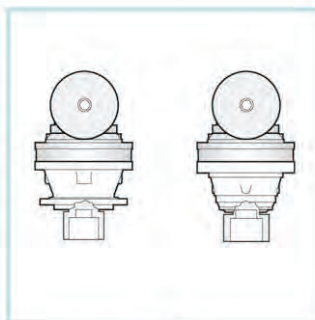

V16

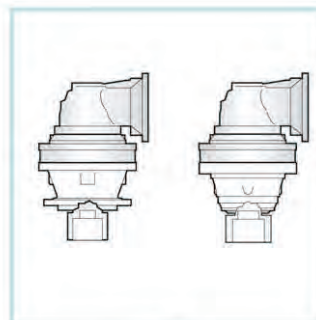

V17

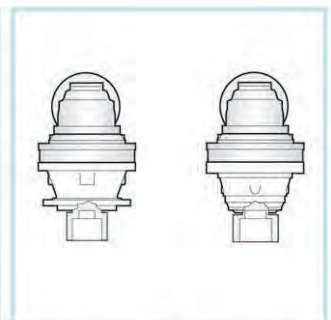

V18

CPC

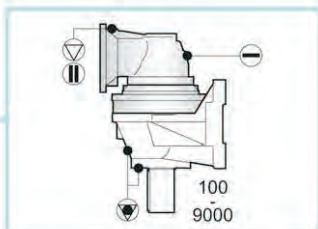

V53

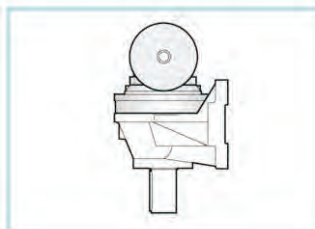

V52

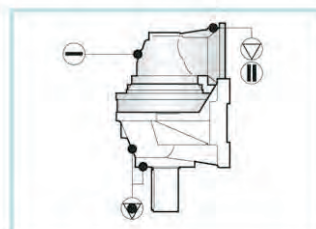

V54

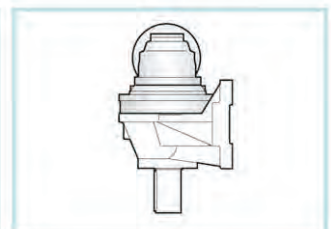

V55

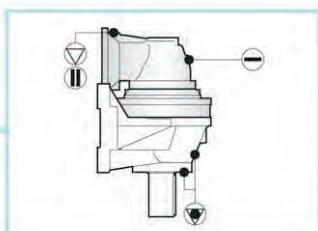

V49

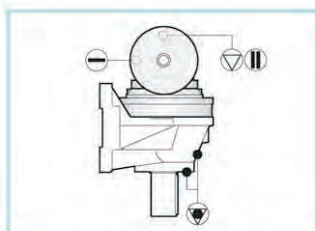

V48

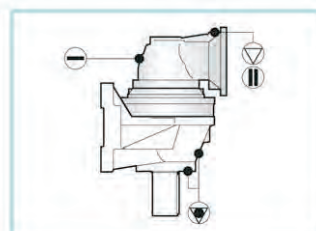

V50

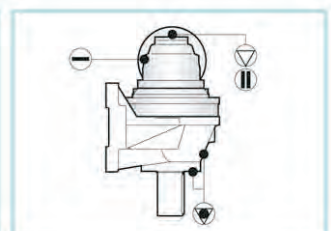

V51

LUBRIFICAZIONE
LUBRICATION
LUBRIFICATION
SCHMIERUNG

Posizioni di montaggio

Mounting positions

Positions de montage

Einbauposition

M-P

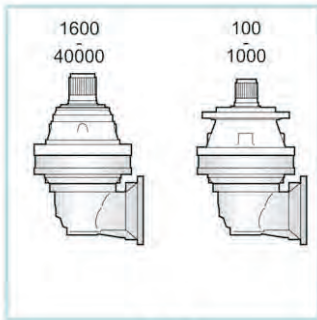

V35

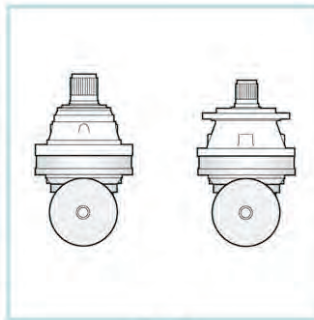

V36

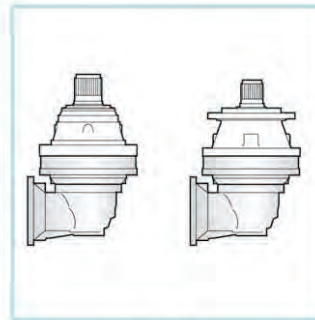

V37

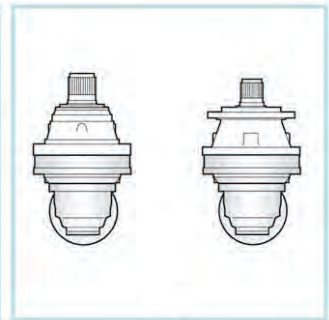

V38

F

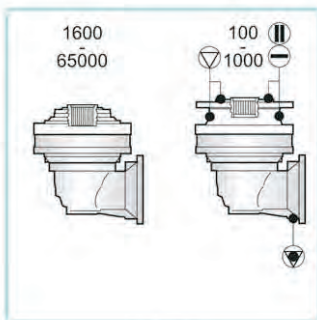

V35

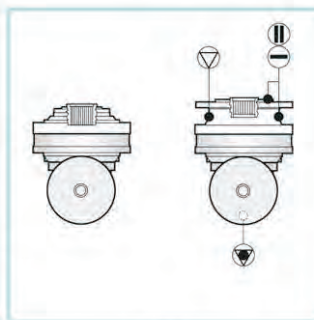

V36

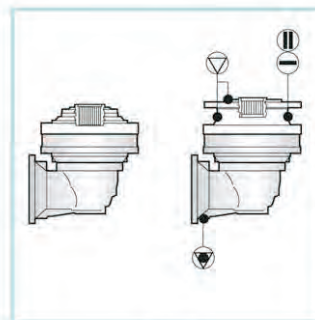

V37

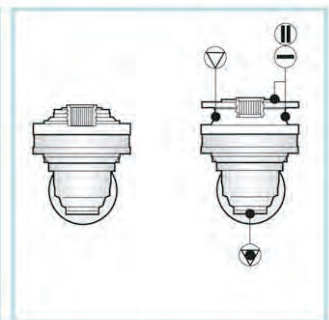

V38

FS

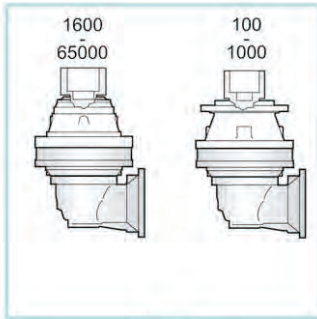

V35

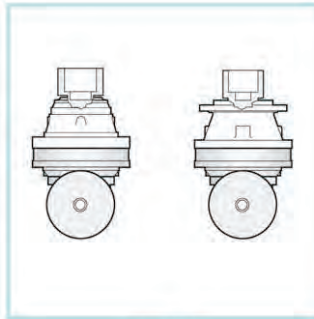

V36

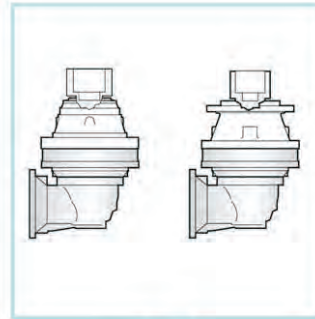

V37

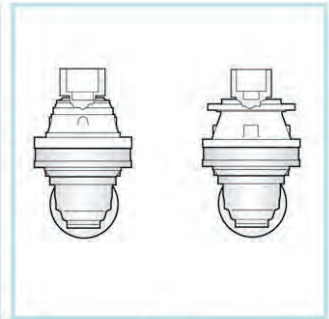

V38

CPC

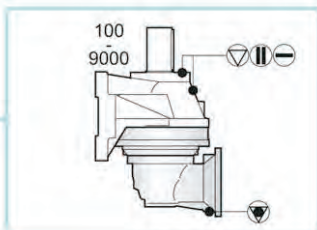

V42

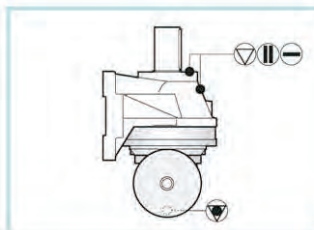

V40

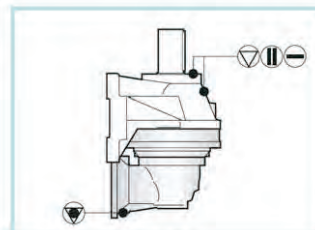

V41

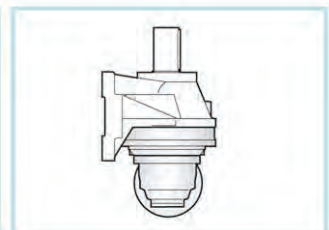

V43

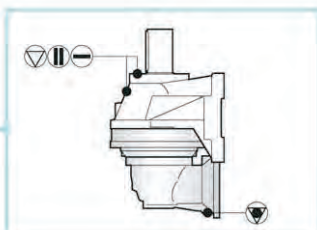

V46

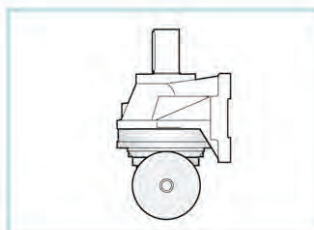

V44

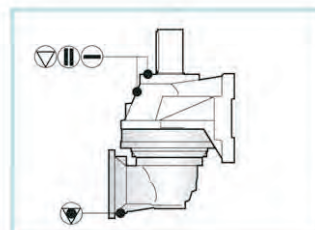

V45

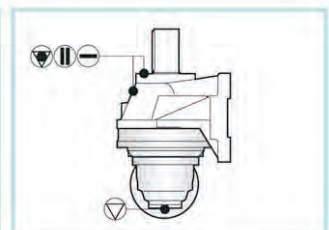

V47

LAYOUT

ACCESSORI USCITA
OUTPUT FITTINGS
ACCESSOIRES DE SORTIE
ABTRIEBSBAUTEILE

VERSIONI USCITA
OUTPUT TYPES
TYPES DE SORTIE
ABTRIEBSWELLEN

FORMA COSTRUTTIVA
TYPE OF REDUCTION UNIT
TYPE DU REDUCTEUR
PLANETENSTUFEN

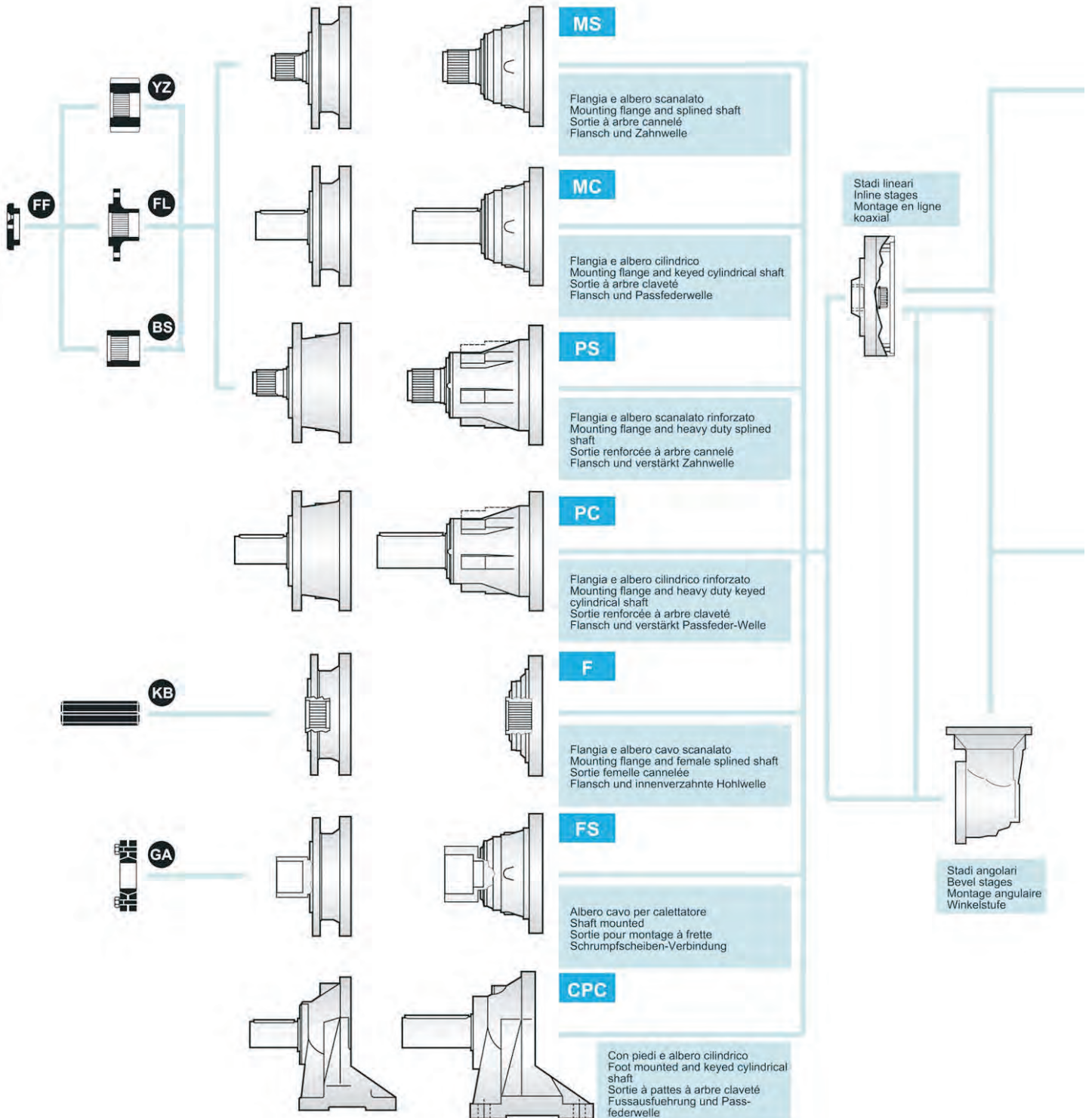

LAYOUT

ACCESSORI ENTRATA INPUT FITTINGS ACCESSOIRES D'ENTREE ANTRIEBSBAUTEILE

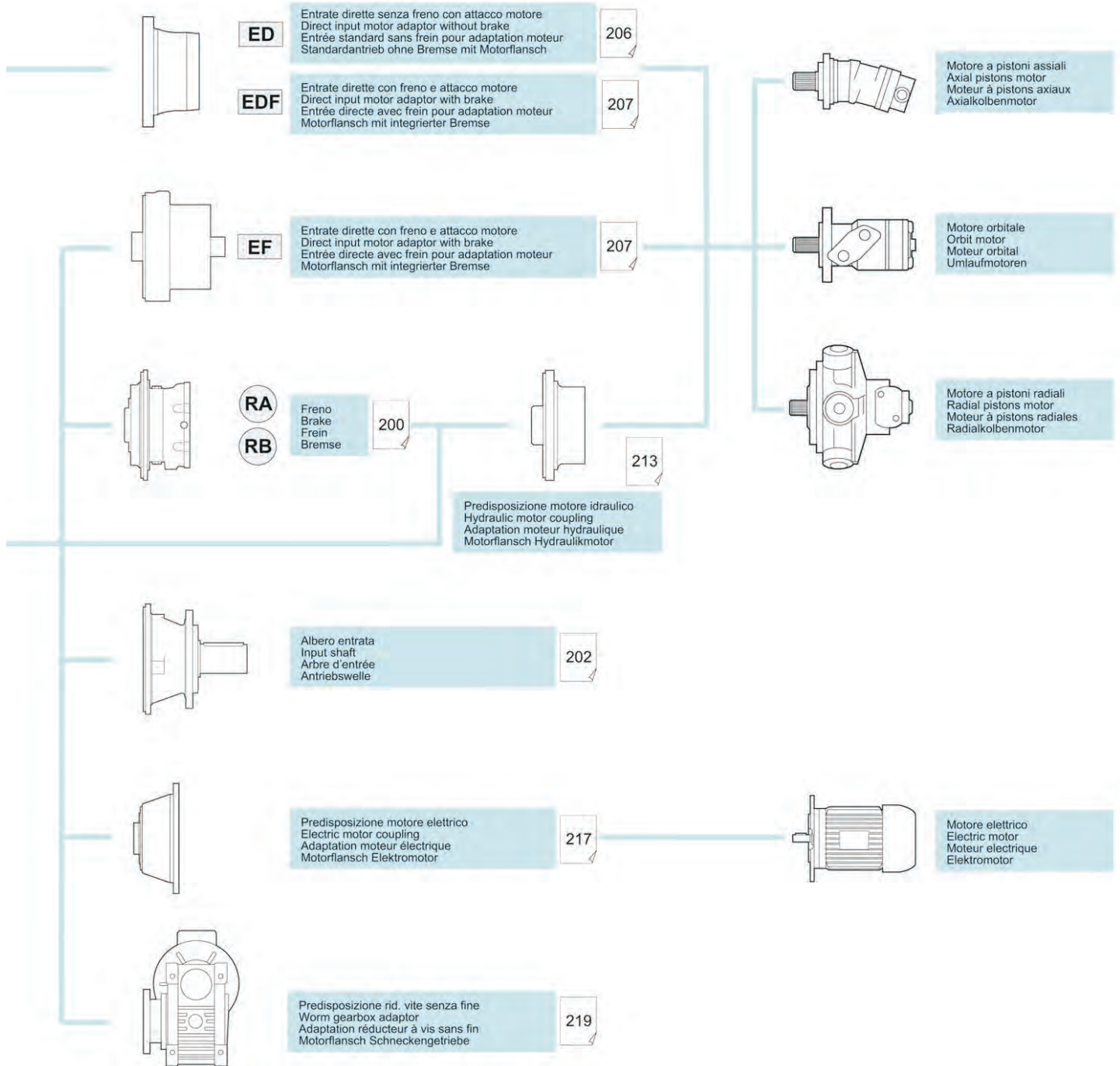

DESIGNAZIONE PRODOTTO
 PRODUCT IDENTIFICATION
 DESIGNATION PRODUIT
 PRODUKTBESCHREIBUNG

RIDUTTORE / GEAR UNIT / REDUCTEUR / GETRIEBE

P G 1 4 0 0 5 M S 1 0 1 3 . 1 6

RAPPORTO / RATIO
 RAPPORT / VERHÄLTNIS

i Vedi schede tecniche / See technical sheets
 Voir fiches techniques / Siehe Datenblätter

VERSIONE E ALBERODI USCITA / OUTPUT TYPE AND SHAFT
 VERSION ET ARBRE DE SORTIE / ABTRIEBSBAUTEILE UND ABTRIEBSWELLE

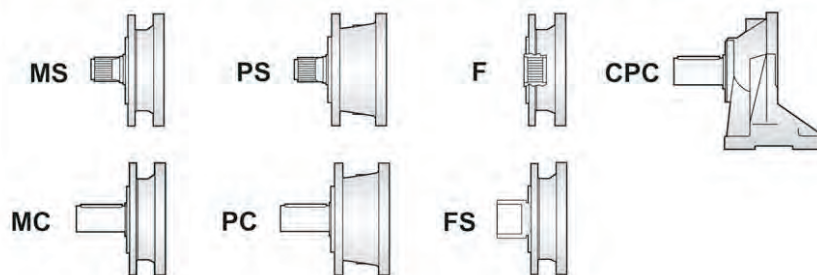

N° STADI / N° STAGES
 N° ETAGES / N° STUFEN

1, 2, 3, 4, 5

GRANDEZZA / SIZE
 TAILLE / GRÖSSE

100, 160, 250, 500, 700, 1000, 1600, 1800, 2500, 3000, 3500, 5000, 6500, 9000, 14000, 18000, 22000, 33000, 40000, 55000, 65000

FORMA COSTRUTTIVA / TYPE OF REDUCTION UNIT
 TYPE DU REDUCTEUR / BAUFORM GETRIEBESTUFEN

PG

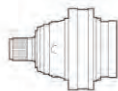

Riduttore con stadi lineari / Inline stages gear unit / Réducteur avec montage en ligne / koaxiale Ausfuehrung

PGA



Riduttore con stadi angolari / Bevel stages gear unit
 Réducteur avec montage angulaire / Ausfuehrung mit Winkelstufe

Esempio di ordinazione:
 Example of order:
 Exemple de commande:
 Beispiel Bestellbeschreibung:

PG 14005 MS 1013.16

DESIGNAZIONE PRODOTTO
 PRODUCT IDENTIFICATION
 DESIGNATION PRODUIT
 PRODUKTBESCHREIBUNG

ACCESSORI / FITTINGS / ACCESSOIRES / BAUTEILE

B S **F F** **R A 2 5 4 7 0 6 ...** **S A E A 4 7 0 2 ...** **V 1**

USCITA / OUTPUT
 SORTIE / ABTRIEB

ENTRATA / INPUT
 ENTREE / ANTRIEB

POSIZIONE DI MONTAGGIO
 MOUNTING POSITION
 POSITION DE MONTAGE
 EINBAUPOSITION

Vedi schede tecniche / See technical sheets
 Voir fiches techniques / Siehe Datenblätter

Freni modulari / Brake
 Frein / Bremse

RA
RB

Albero entrata / Input shaft
 Arbre d'entrée / Antriebswelle

EL28, EL42, ...

Predisposizione motore elettrico / Electric motor coupling
 Adaptation moteur électrique / Motorflansch
 Elektromotor

H71, H80, ...

Predisposizione motore idraulico/Hydraulic motor
 coupling
 Adaptation moteur hydraulique/Motorflansch Hydraulikmotor

SAE A, SAE B, ...

Entrata diretta con freno e attacco motore / Direct input motor adaptor with brake
 Entrée directe avec frein pour adaptation moteur / Motorflansch mit integrierter Bremse

EDF
EF

Entrata diretta senza freno e con attacco motore / Direct input motor adaptor without brake
 Entrée directe sans frein pour adaptation moteur / Standardantrieb

ED

Accessori di uscita / Output fittings
 Accessoires de sortie / Abtriebsbauteile

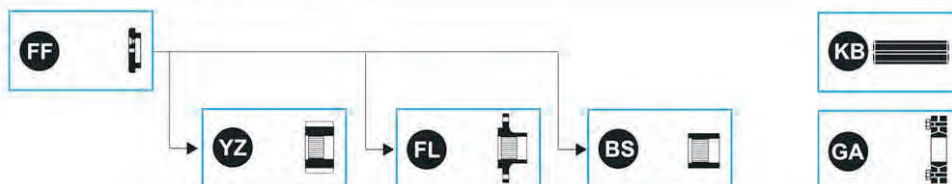

Esempio di ordinazione:
 Example of order:
 Exemple de commande:
 Beispiel Bestellbeschreibung:

BS FF RA 25 4706.002.500 SAE A 4702.012.012 V1

**SIMBOLOGIA
LEGEND
SYMBOLES
LEGENDE**

Cfs	[Nm]	Coppia frenante statica	Static braking torque	Couple de freinage statique	Bremsmoment, statisch
Fa	[N]	Carico assiale	Axial load	Charge axiale	Axiallast
fh		Fattore di durata	Duraction factor	Facteur de durée	Lebensdauerfaktor
fk		Fattore di adeguamento della capacità termica	Thermal power adjustment factor	Facteur d'adaptation de la capacité thermique	Anpassungsfaktor Waerme-kapazitaet
Fr	[N]	Carico radiale	Radial load	Charge radiale	Radiallast
fs		Fattore di servizio	Service factor	Facteur de service	Betriebsfaktor
		Rendimento	Efficiency	Rendement	Wirkungsgrad
i		Rapporto di riduzione	Ratio	Rapport	Übersetzung
K		Coefficiente di correzione del carico radiale	Radial load correction factor	Facteur de correction de charge radiale	Korrekturkoeffizient der Radiallast
Kg	[Kg]	Peso	Weight	Poids	Gewicht
Mc	[kNm]	Coppia continua	Continuous torque	Couple continu	Dauerbetriebsmoment
Me	[kNm]	Coppia equivalente	Equivalent working torque	Couple equivalent	Equivalentes Betriebsmoment
M_{max}	[kNm]	Coppia massima	Maximum torque	Couple maximal	Maximales Betriebsmoment
Mp	[kNm]	Coppia di picco	Working peak torque	Couple maximum de travail	Spitzenmoment
n_{1 max}	[min ⁻¹]	Velocità massima in entrata	Maximum input speed	Vitesse maximale d'entrée	Max. zulaessige Antriebsdrehzahl
n₂	[min ⁻¹]	Velocità in uscita	Output speed	Vitesse de sortie	Abtriebsdrehzahl
nxh		Numero cicli	Cycles number	N ^o de cycles	Anzahl der Zyklen
Pa_{min}	[bar]	Pressione di apertura	Opening pressure	Pression d'ouverture	Bremsoeffnungsdruck
P_{max}	[bar]	Pressione massima	Max pressure	Pression maxi	Max. Betriebsdruck Bremse
Pt	[kW]	Potenza termica	Thermal power	Puissance thermique	Thermische Leistung
		Informazioni	Information	Information	Information
		Quantità lubrificante	Oil quantity	Quantité d'huile	Oelmenge

**SCHEDE TECNICHE RIDUTTORI
PLANETARY GEARS TECHNICAL SHEETS
FICHES TECHNIQUES REDUCTEURS
TECHNISCHE DATENBLÄTTER GETRIEBE**

PG PGA	i	kNm	
100	3,55 - 3422	1,00	42
160	3,55 - 3422	1,60	50
250	3,77 - 2369	2,50	58
500	3,77 - 1845	5,00	66
700	3,66 - 2969	7,00	74
1000	3,55 - 2230	10,00	82
1600	3,55 - 2230	16,00	90
1800	13,00 - 1216	18,00	98
2500	4,00 - 1774	25,00	106
3000	14,20 - 1425	30,00	114
3500	4,00 - 1290	35,00	122
5000	4,00 - 1982	50,00	130
6500	3,83 - 1008	65,00	138
9000	4,00 - 1623	90,00	146
14000	3,83 - 5674	140,00	154
18000	3,91 - 9793	180,00	162
22000	3,68 - 8263	220,00	170
33000	4,09 - 8522	330,00	178
40000	3,83 - 5156	400,00	184
55000	3,84 - 5571	550,00	190
65000	3,84 - 5571	650,00	194

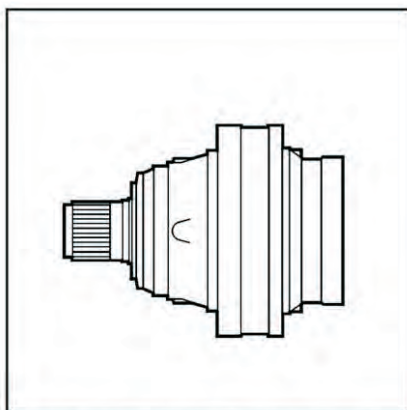

Le pagine che seguono riportano i dati tecnici prestazionali e dimensionali dei riduttori Serie PG - PGA. Per facilitare la ricerca della grandezza desiderata riportiamo la tabella sopraindicata con i dati indicativi e i riferimenti alle pagine.

The following pages show the technical information on performances and dimensions of the PG-PGA planetary drives range of sizes. To simplify the research and the selection of the required size you can refer to the above table, including some technical data and the corresponding page.

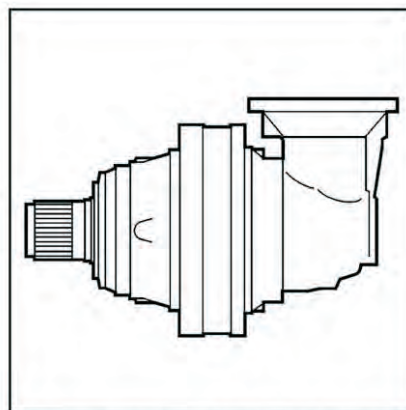

Les pages qui suivent se rapportent aux données techniques des prestations et dimensions des réducteurs série PG -PGA. Pour faciliter la sélection de la taille du réducteur envisagée, se référer au tableau ci-dessus pour se reporter à la page correspondante.

Die folgenden Seiten zeigen die technischen Daten bezüglich Leistung und Dimensionen der Produktserien PG-PGA. Um die Suche der gewünschten Grösse zu erleichtern, liefert die vorstehende Tabelle die Grössen in Verbindung zur entsprechenden Katalogseite.

**LEGENDA
LEGEND
LEGENDE
LEGENDE**

DATI TECNICI / TECHNICAL DATA / DONNEES TECHNIQUES / TECHNISCHE DATEN

PG 501
PG 502
PG 503
PG 504

- 1 Tabelle dei dati tecnici relativi ai riduttori PG.
Technical data tables of PG series.
Tableaux des données techniques sur les séries PG.
Tabelle mit den technischen Daten des entsprechenden PG - Getriebetyps.

PGA 502
PGA 503
PGA 504

- 2 Tabelle dei dati tecnici relativi ai riduttori PGA.
Technical data tables of PGA series.
Tableaux des données techniques sur les séries PGA.
Tabelle mit den technischen Daten des entsprechenden PGA - Getriebetyps.

- 3 Indicazione per il calcolo della coppia massima M_{max} .
Determination of the maximum torque M_{max} .
Indications pour calculer le couple maxi M_{max} .
Anweisung zur Berechnung des maximalen Betriebsdrehmoments M_{max} .

DIMENSIONI / DIMENSIONS / DIMENSIONS / MASSE

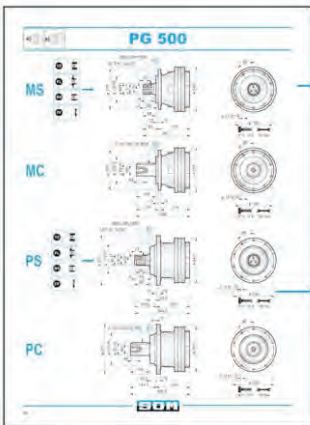

- 4 Queste pagine riportano le dimensioni delle uscite nelle varie configurazioni disponibili.
These pages show the outputs dimensions in their different possible configurations.
Ces pages montrent les dimensions des sorties dans leurs différentes configurations possibles.
Auf diesen Seiten sind die Masse der diversen Abtriebstypen angegeben.

- 5 Questo simbolo fornisce le indicazioni sulle viti da utilizzare per il fissaggio del riduttore.
This symbol gives information about screws to use to mount the gearbox.
Ce symbole donne l'indication des vis à utiliser pour monter le réducteur.
Diese Symbol gibt Hinweise zur Befestigung des Getriebes und die einzusetzenden Schrauben.

M12 10.9 136 Nm

Diametro della vite
Screw diameter
Diamètre de vis
Durchmesser der Schrauben

Classe di resistenza
Screw quality
Classe de résistance
Schraubenfestigkeitsklasse

Coppia di serraggio consigliata
Screw tightened torque
Couple de serrage conseillé
empfohlenes Anzugsdrehmoment

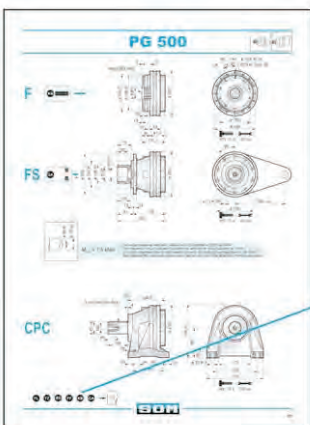

- 6 Simboli riferiti agli accessori applicabili in uscita al riduttore nelle configurazioni disponibili.
Symbols refer to suitable fittings on output in their possible configuration.
Symboles se référant aux accessoires applicables en sortie du réducteur et leurs configurations possibles.
Diese Symbole zeigen die möglichen Optionen im Bezug auf die verfügbaren Abtriebsbauteile.

**LEGENDA
LEGEND
LEGENDE
LEGENDE**

ENTRATE / GEARBOX INPUTS / ENTREES / ANTRIEB

7

Queste pagine riportano le dimensioni di massimo ingombro del riduttore nelle varie configurazioni disponibili e i tipi di entrate, freni e motorizzazioni applicabili con l'indicazione delle pagine nelle quali reperire ulteriori dati.

These pages show overall dimensions of the gearboxes in their possible configurations plus the type of gearbox inputs, brakes and motor drives applicable with indication of the pages in which to find further information.

Ces pages montrent les dimensions extérieures des réducteurs dans leurs configurations possibles ainsi que les sortes d'entrées, freins et d'adaptations moteurs applicables avec les indications des pages dans lesquelles se trouvent de plus amples informations.

Diese Seiten geben die Aussenmasse der diversen Getriebetypen an. Dazu werden die moeglichen Optionen der verfügbaren Antriebsformen, Bremsen gezeigt und auf die entsprechenden Katalogseiten hingewiesen.

8

Il massimo ingombro del riduttore è ottenuto (come illustrato nei disegni seguenti) sommando alle quote A e B le dimensioni delle entrate utilizzate (L, P, Z) e le eventuali maggiorazioni dimensionali dove indicate.

Maximum gearbox overall dimension is obtained (see scheme below) adding the input dimensions used (L, P, Z) to a and b dimensions, plus possible oversize if indicated.

La dimension extérieure maximum du réducteur est obtenue (voir schéma ci-dessous) en additionnant les dimensions des entrées utilisées (L, P, Z) aux dimensions A et B, plus la cote additionnelle si indiquée.

Das Gesamtausmass des Getriebes wird ermittelt (wie im nachstehenden Schema gezeigt), indem die Angaben aus dem vorgenannten Abtriebsausmass A und B, das Laengenmass des gewaehlten Antriebs (L, P, Z) und eventuellen Aufmasse (wenn angezeigt) addiert werden.

9

I simboli (•) riportati nelle tabelle indicano l'applicabilità dei freni (RA, RB) e delle entrate ED, EDF, EF.

I simboli (o) indicano ugualmente l'applicabilità degli stessi componenti prevedendo una maggiorazione di lunghezza (come evidenziato nello schema sopra riportato).

The tables, show the suitability of the brakes (RA and RB) and of the inputs ED, EDF, EF. Symbols marked with (o) in the tables, also show the suitability of the same components increasing the length (as shown in the scheme above).

Les symboles marqués d'un (•) dans les tableaux, montrent l'adaptation des freins (RA et RB) et des entrées ED, EDF, EF. Les symboles marqués d'un (o) dans les tableaux, montrent également l'adaptation des mêmes composants en augmentant la longueur (comme montré dans le schéma ci-dessous).

Das Symbol (•) in der Tabelle gibt an, welcher Bremsentyp (RA, RB) und welche Form der Antriebsvorrichtung ED, EDF oder EF verwendet werden kann. Das Symbol (o) hat dieselbe Funktion. Zusätzlich wird auf ein zu berücksichtigendes Aufmass hingewiesen (siehe oberes Schema).

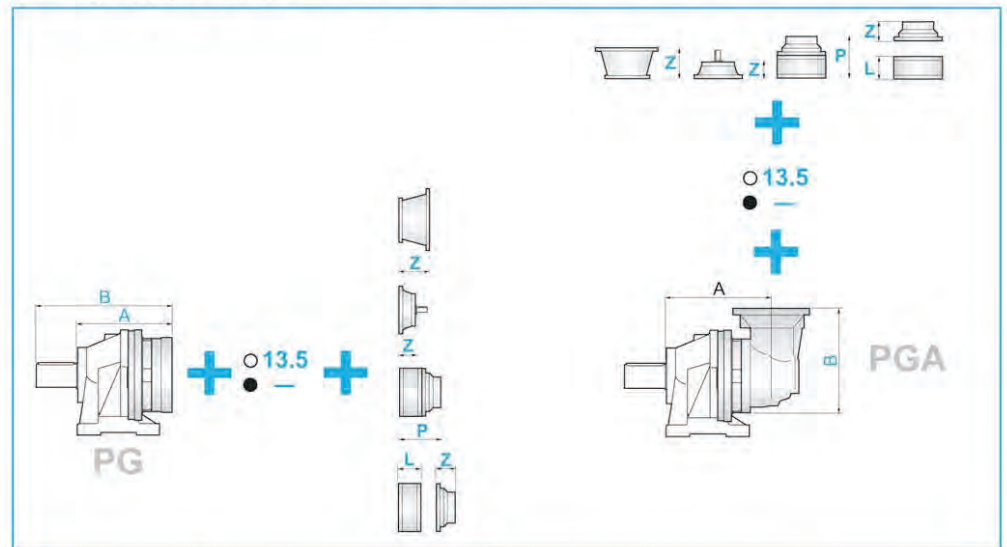

**ACCESSORI USCITA
OUTPUT ACCESSORIES
ACCESSOIRES DE SORTIE
ABTRIEBSBAUTEILE**

Questa pagina riporta le dimensioni degli accessori disponibili.

This page shows dimensions of the available accessories.

Cette page montre les dimensions des accessoires disponibles.

Diese Seite gibt die Dimensionsmasse der verfügbaren Abtriebsbauteile an.

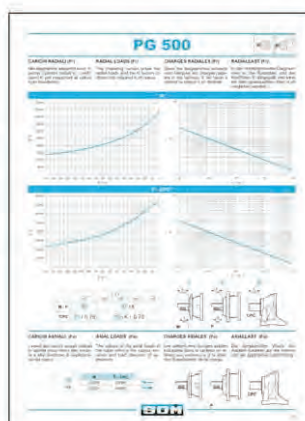

**CARICHI RADIALI E ASSIALI
RADIAL AND AXIAL LOADS
CHARGES RADIALES ET AXIALES
RADIALLAST UND AXIALLAST**

Questa pagina riporta i diagrammi dai quali si ricavano i carichi radiali sugli alberi in uscita e le tabelle con i valori dei carichi assiali.

This page shows graphs to determine radial loads on output shafts and tables for axial load values.

Cette page montre les diagrammes des charges radiales sur les arbres de sortie et les tableaux avec les valeurs des charges axiales.

Diese Seite zeigt die Diagramme, aus denen die Werte der Radiallast auf An- oder Abtriebswelle ermittelt werden koennen. Dazu sind hier die Tabellen mit den Werten der Axiallast ersichtlich.



PG 100

	i	Mc [kNm]				n1max [min ⁻¹]	Pt [kW]	Kg				
		n ₂ x h	n ₂ x h	n ₂ x h	n ₂ x h			M	P	CPC	F	FS
		10.000	20.000	50.000	100.000							
PG 101	3.55	1.24	1.10	0.94	0.83	2800	12	13	15	18	11	14
	4.28	1.24	1.10	0.94	0.83							
	5.60	0.90	0.80	0.68	0.60							
	6.75	0.79	0.70	0.60	0.53							
	8.67	0.51	0.45	0.38	0.34							
PG 102	12.6	1.24	1.10	0.94	0.83	2800	8	19	21	24	17	20
	15.2	1.24	1.10	0.94	0.83							
	19.9	1.24	1.10	0.94	0.83							
	23.9	1.24	1.10	0.94	0.83							
	28.9	1.24	1.10	0.94	0.83							
	31.4	0.90	0.80	0.68	0.60							
	37.8	0.90	0.80	0.68	0.60							
	45.5	0.79	0.70	0.60	0.53							
	58.5	0.79	0.70	0.60	0.53							
PG 103	54.1	1.24	1.10	0.94	0.83	2800	5	25	27	30	23	26
	65.3	1.24	1.10	0.94	0.83							
	70.7	1.24	1.10	0.94	0.83							
	78.7	1.24	1.10	0.94	0.83							
	85.3	1.24	1.10	0.94	0.83							
	102.8	1.24	1.10	0.94	0.83							
	111.5	1.24	1.10	0.94	0.83							
	134.3	1.24	1.10	0.94	0.83							
	161.9	1.24	1.10	0.94	0.83							
	172.5	1.24	1.10	0.94	0.83							
	207.9	1.24	1.10	0.94	0.83							
	211.6	0.90	0.80	0.68	0.60							
	255.1	0.90	0.80	0.68	0.60							
	271.7	0.90	0.80	0.68	0.60							
	307.5	0.79	0.70	0.60	0.53							
	327.5	0.90	0.80	0.68	0.60							
394.8	0.79	0.70	0.60	0.53								
PG 104	337.3	1.24	1.10	0.94	0.83	2800	1.5	31	33	36	29	32
	365.7	1.24	1.10	0.94	0.83							
	396.4	1.24	1.10	0.94	0.83							
	440.8	1.24	1.10	0.94	0.83							
	477.8	1.24	1.10	0.94	0.83							
	531.3	1.24	1.10	0.94	0.83							
	575.9	1.24	1.10	0.94	0.83							
	624.4	1.24	1.10	0.94	0.83							
	694.2	1.24	1.10	0.94	0.83							
	752.6	1.24	1.10	0.94	0.83							
	836.8	1.24	1.10	0.94	0.83							
	907.1	1.24	1.10	0.94	0.83							
	966.3	1.24	1.10	0.94	0.83							
	1093.4	1.24	1.10	0.94	0.83							
	1144.5	1.24	1.10	0.94	0.83							
	1185.4	0.90	0.80	0.68	0.60							
	1318.0	1.24	1.10	0.94	0.83							
	1428.8	0.90	0.80	0.68	0.60							
	1692.3	1.24	1.10	0.94	0.83							
	3422.1	0.79	0.70	0.60	0.53							

PG 100



	i	Mc [kNm]				n1max [min ⁻¹]	Pt [kW]	Kg				
		n2 x h	n2 x h	n2 x h	n2 x h			M	P	CPC	F	FS
		10.000	20.000	50.000	100.000							
PGA 102	10.4	1.24	1.10	0.94	0.83	2800	8	28	30	33	26	29
	12.5	1.24	1.10	0.94	0.83							
	16.4	0.90	0.80	0.68	0.60							
	19.7	0.79	0.70	0.60	0.53							
PGA 103	37.0	1.24	1.10	0.94	0.83	2800	5	34	36	39	32	35
	44.6	1.24	1.10	0.94	0.83							
	53.8	1.24	1.10	0.94	0.83							
	58.4	1.24	1.10	0.94	0.83							
	70.3	1.24	1.10	0.94	0.83							
	84.8	1.24	1.10	0.94	0.83							
	91.9	0.90	0.80	0.68	0.60							
	110.8	0.90	0.80	0.68	0.60							
	133.6	0.79	0.70	0.60	0.53							
	171.5	0.79	0.70	0.60	0.53							
PGA 104	131.8	1.24	1.10	0.94	0.83	2800	1.5	40	42	45	38	41
	158.9	1.24	1.10	0.94	0.83							
	191.5	1.24	1.10	0.94	0.83							
	207.6	1.24	1.10	0.94	0.83							
	230.8	1.24	1.10	0.94	0.83							
	301.7	1.24	1.10	0.94	0.83							
	327.0	1.24	1.10	0.94	0.83							
	363.6	1.24	1.10	0.94	0.83							
	394.2	1.24	1.10	0.94	0.83							
	475.1	1.24	1.10	0.94	0.83							
	515.3	0.90	0.80	0.68	0.60							
	572.7	1.24	1.10	0.94	0.83							
	610.1	1.24	1.10	0.94	0.83							
	735.4	1.24	1.10	0.94	0.83							
	797.2	0.90	0.80	0.68	0.60							
	960.9	0.90	0.80	0.68	0.60							
	1158.2	0.79	0.70	0.60	0.53							
	1233.7	0.90	0.80	0.68	0.60							
	1487.1	0.79	0.70	0.60	0.53							



(n2 x h = 20.000)

$$M_{\max} = M_c \times 2$$

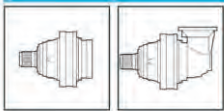

PG 100

MS

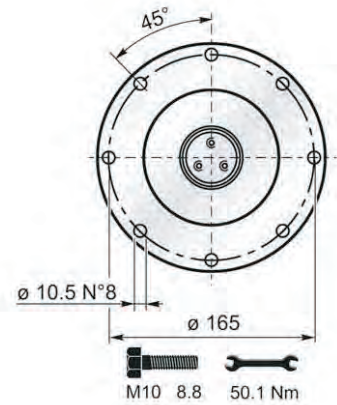
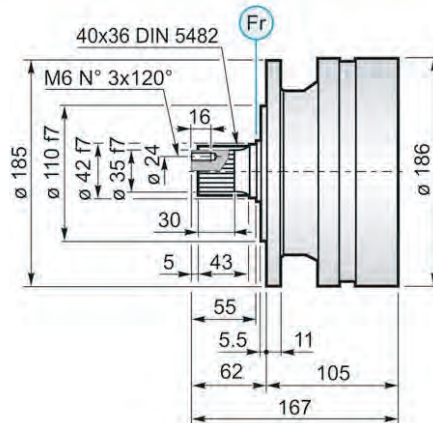
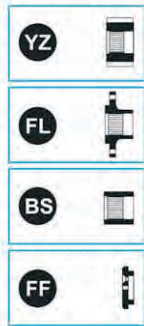

MC

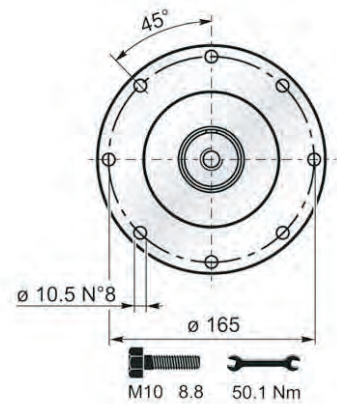
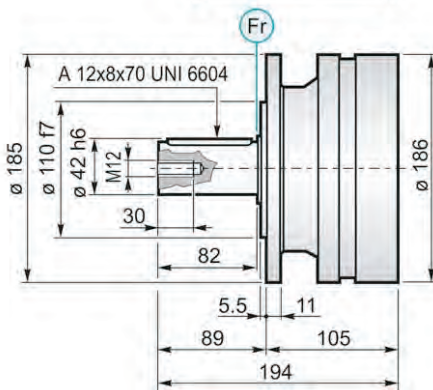

PS

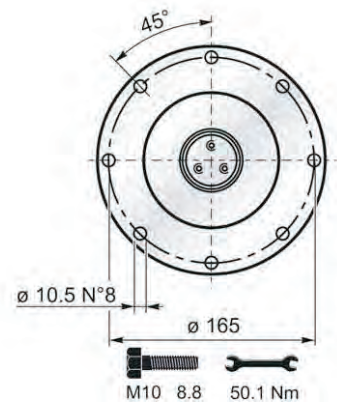
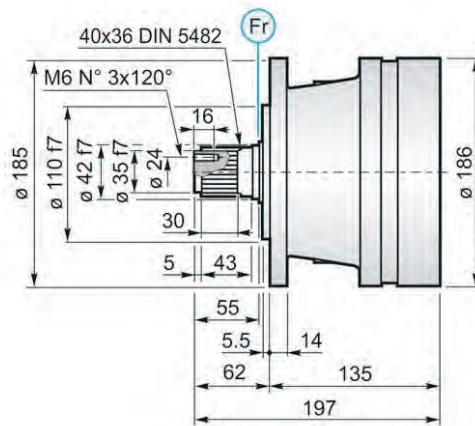

PC

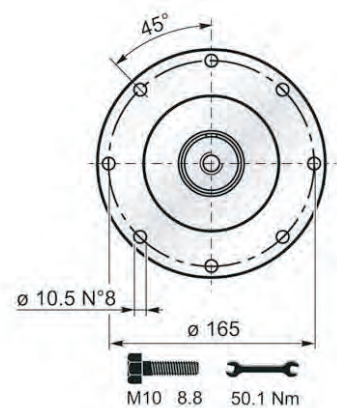
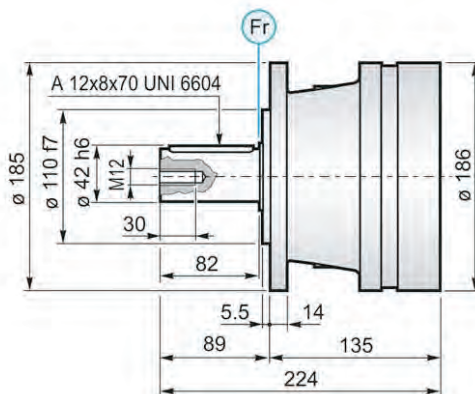

PG 160



	PGA		...MS		
	A	B	RA	RB	EF
PGA 162	193	159	•		•
PGA 163	241	159	•		•
PGA 164	289	159	•		•

	PGA		...MC		
	A	B	RA	RB	EF
PGA 162	193	159	•		•
PGA 163	241	159	•		•
PGA 164	289	159	•		•

	PGA		...PS		
	A	B	RA	RB	EF
PGA 162	223	159	•		•
PGA 163	271	159	•		•
PGA 164	319	159	•		•

	PGA		...PC		
	A	B	RA	RB	EF
PGA 162	223	159	•		•
PGA 163	271	159	•		•
PGA 164	319	159	•		•

	PGA		...F		
	A	B	RA	RB	EF
PGA 162	193	159	•		•
PGA 163	241	159	•		•
PGA 164	289	159	•		•

	PGA		...FS		
	A	B	RA	RB	EF
PGA 162	193	159	•		•
PGA 163	241	159	•		•
PGA 164	289	159	•		•

	PGA		...CPC		
	A	B	RA	RB	EF
PGA 162	230	159	•		•
PGA 163	278	159	•		•
PGA 164	326	159	•		•

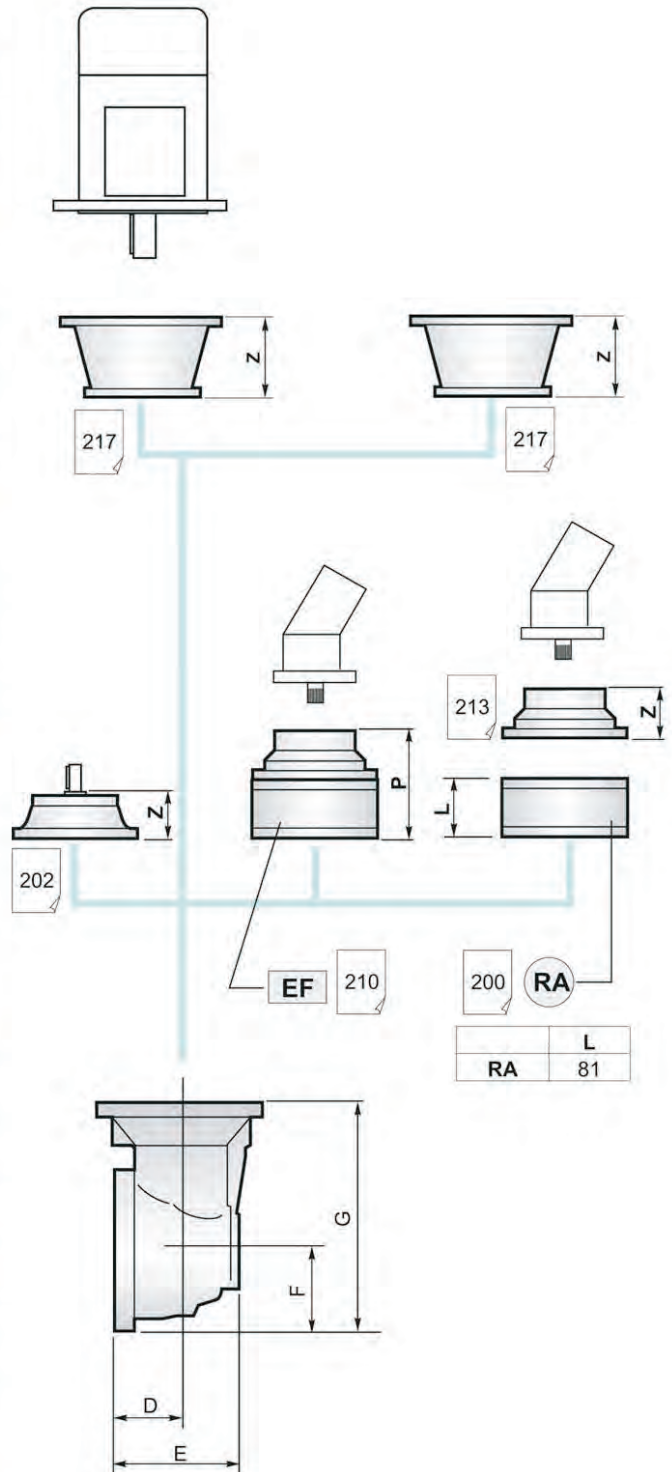

	D	E	F	G
PGA 162	75	141.5	93	252
PGA 163	75	141.5	93	252
PGA 164	75	141.5	93	252

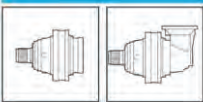

PG 160

YZ Pignoni / Pinion Pignon / Ritzel

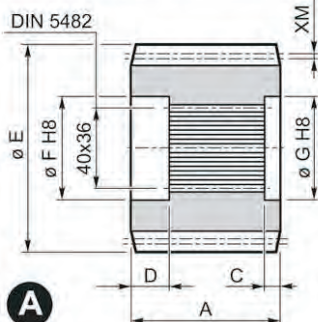

	Versione Output type Version Abtriebs- version	M	Z	XM	A	B	C	D	E	F	G	K	Materiale Material Matière Material	Code Code Code Bestell - Nr.
A	M.. - P..	1.9	20	0.049	65	—	6	20.5	84.5	42	42	—	38NiCrMo4	1701.200.042
	M.. - P..	5	16	2.5	55	—	6	20.5	95	42	42	—	38NiCrMo4	1701.259.042
B	M.. - P..	3.5	23	0	40	60.5	6	20.5	87.5	42	42	60	38NiCrMo4	1701.291.042

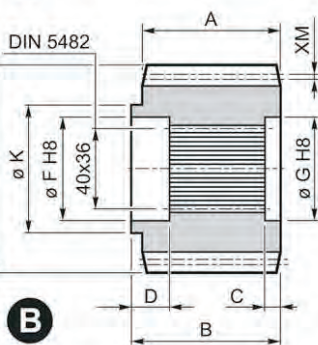

FF Fondello di arresto / Stop bottom plate Bouchon de fermeture / Endscheibe

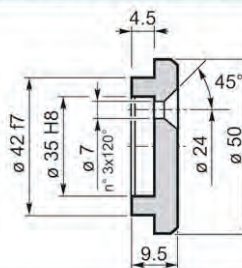

Codice / Code
Code / Bestell - Nr.
5701.034.000

BS Boccola scanalata / Splined bushing Moyeu cannelé / Innenverzahnte Buchse

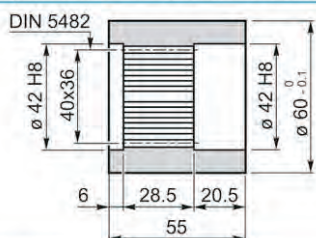

Materiale / Material
Matière / Material
UNI C40
SAE 1040
DIN Ck40

Codice / Code
Code / Bestell - Nr.
1710.100.076

KB Barra scanalata / Splined rod Arbre cannelé / Außenverzahnte Welle



Materiale / Material
Matière / Material
UNI 39NiCrMo3
bonificato
hardened and tempered
bonifié
vergulét

Codice / Code
Code / Bestell - Nr.
1703.179.042

FL Flangia / Flange Bride / Flansch

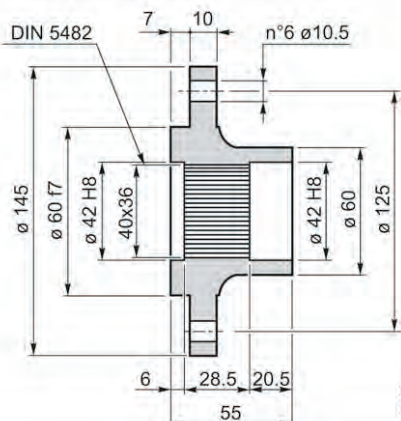

Codice / Code
Code / Bestell - Nr.
1710.102.025

GA Giunto di attrito / Shrink disc Frette de serrage / Schrumpfscheibe

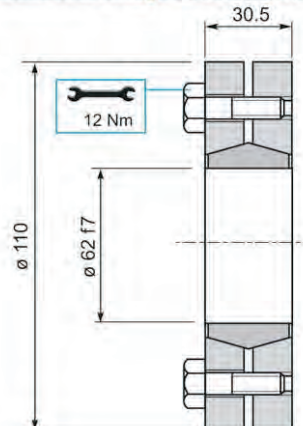

Coppia max.
Max. torque
Couple max.
Max. Drehmoment
2.2 kNm

Codice / Code
Code / Bestell - Nr.
9015.062.000

PG 160

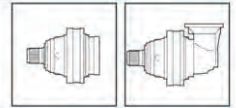

CARICHI RADIALI (Fr)

Nei diagrammi seguenti sono riportati i carichi radiali e i coefficienti K per rapportarli al valore $n_2 \times h$ desiderato.

RADIAL LOADS (Fr)

The following curves show the radial loads and the K factors to obtain the required $n_2 \times h$ value.

CHARGES RADIALES (Fr)

Dans les diagrammes suivants sont indiqués les charges radiales et les facteurs K de façon à obtenir la valeur $n_2 \times h$ désirée.

RADIALLAST (Fr)

In den nachstehenden Diagrammen ist die Radiallast und der Koeffizient K dargestellt und kann mit dem gewünschten Wert $n_2 \times h$ verglichen werden.

M

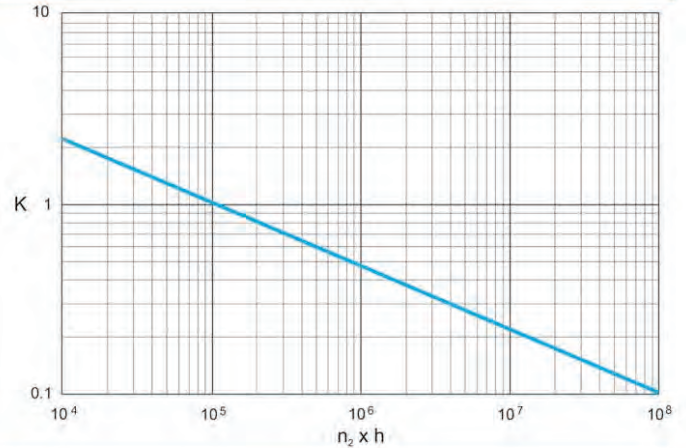
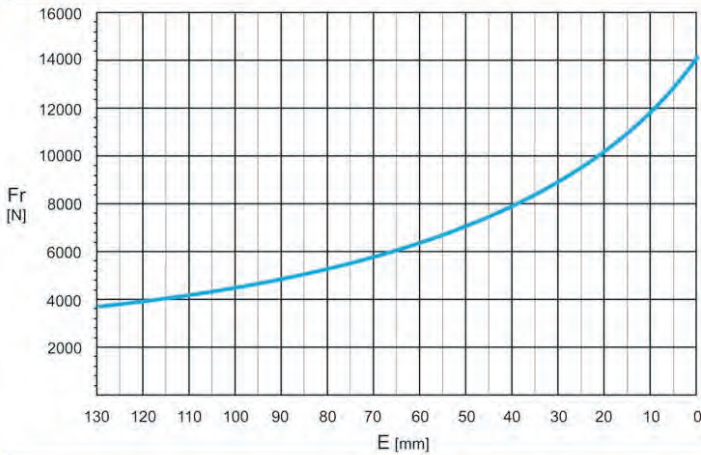

P - CPC*

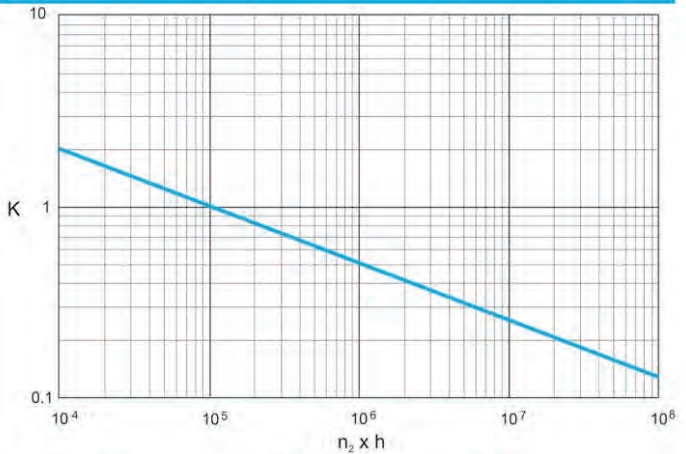
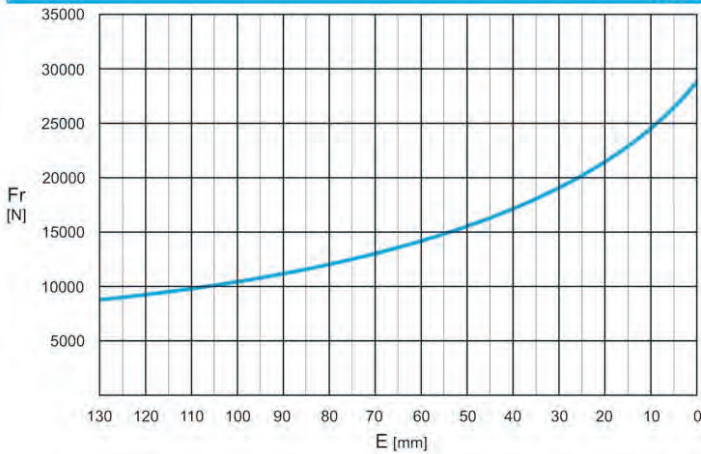

	$n \times h$				
	10^5	10^4	10^6	10^7	10^8
M - P	Fr			Fr • K	
*CPC	Fr • 0.75			Fr • K • 0.75	

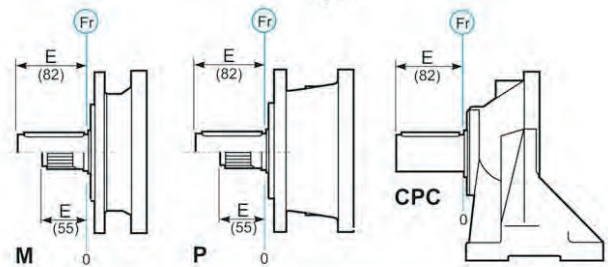

CARICHI ASSIALI (Fa)

I valori dei carichi assiali indicati in tabella sono riferiti alle versioni e alla direzione di applicazione del carico.

AXIAL LOADS (Fa)

The values of the axial loads in the table refer to the output versions and load direction of application.

CHARGES AXIALES (Fa)

Les valeurs des charges axiales indiquées dans le tableau se réfèrent aux versions et à la direction d'application de la charge.

AXIALLAST (Fa)

Die dargestellten Werte der Axiallast basieren auf der Version und der applizierten Lastrichtung.

Fa [N]	M	P - CPC	← →
		16000	

