

Part number:



# CHM7

## PILOT OPERATED CHECK VALVE

### SERIES 11

#### MODULAR VERSION

#### ISO 4401-07

**p** max 350 bar  
**Q** max 300 l/min

#### MOUNTING INTERFACE

ISO 4401-07-07-0-05  
(CETOP 4.2-4-07)

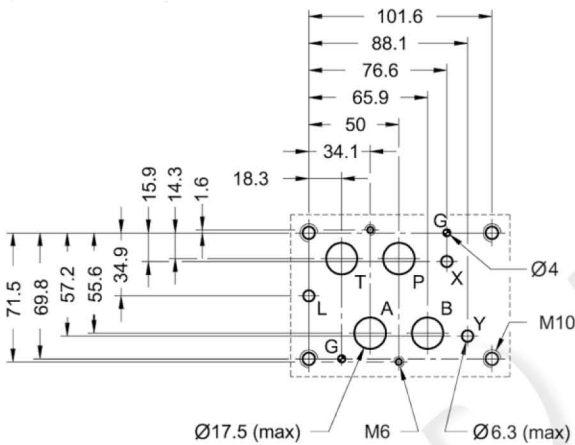

#### OPERATING PRINCIPLE

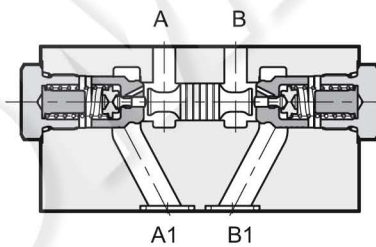

- This is a hydraulically released check valve with spring closing and with cone on edge seals; the mounting surface is according to the ISO 4401 standards.
- Its use allows:
  - prevention of flow in one direction;
  - flow in the same direction, if opened by a pilot pressure;
  - free flow in the other direction.
- The CHM7 valves are always mounted downstream of the DSP7 type directional solenoid valves (see cat. 41 420) and can be assembled with all other ISO 4401-07 valves.

#### CONFIGURATIONS (see hydraulic symbols table)

- Configuration "SA" –"SB": is used to lock the actuator in one direction.
- Configuration "D": is used to lock the actuator position in both directions.

The opening of the valve is gradual and occurs with the pre-opening of the main shutter that permits the plant decompression.

#### PERFORMANCE RATINGS (measured with mineral oil of viscosity 36cSt at 50°C)

Maximum operating pressure	bar	350
Maximum flow rate	l/min	300
Ratio between pressure of the sealed chamber and the piloting pressure		13:1
Opening pressure	bar	2
Ambient temperature range	°C	-25 / +80
Fluid temperature range	°C	-25 / +80
Fluid viscosity range	cSt	10 ÷ 400
Fluid contamination degree	According to ISO 4406:1999 class 20/18/15	
Recommended viscosity	cSt	25
Mass: CHM7-S*	kg	7,6
CHM7-D	kg	7,7

#### HYDRAULIC SYMBOLS

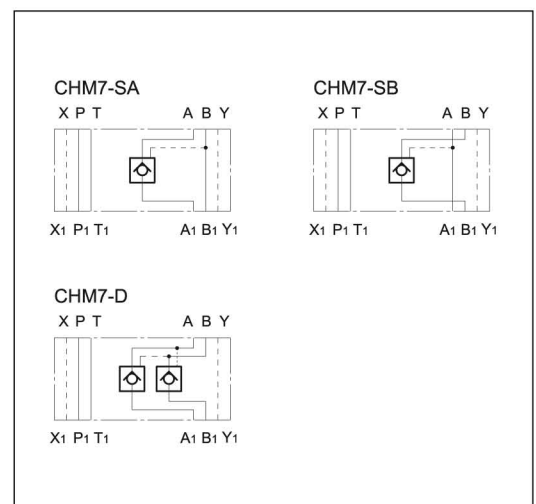

### 1 - IDENTIFICATION CODE

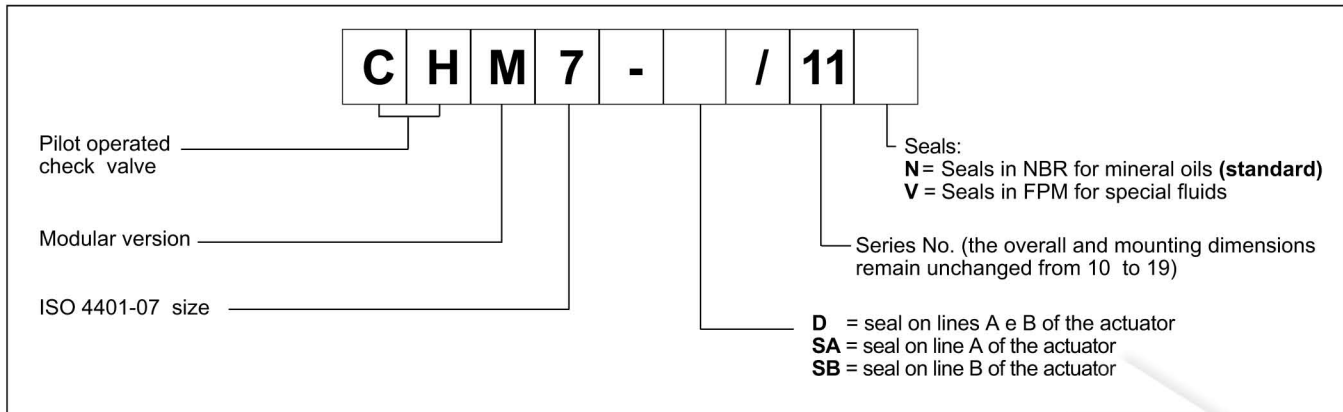

### 2 - CHARACTERISTIC CURVES

(values obtained with viscosity of 36 cSt at 50°C)

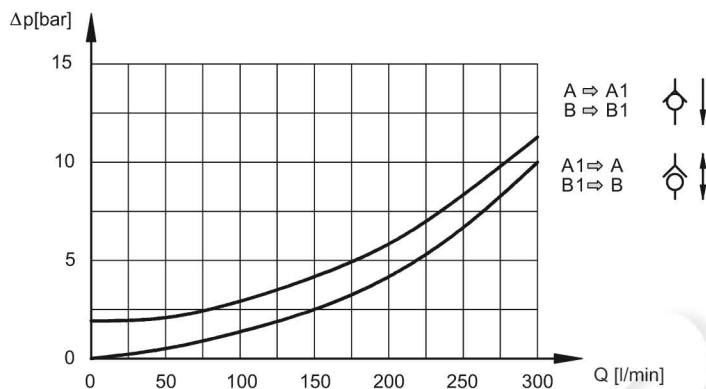

### 3 - HYDRAULIC FLUIDS

Use mineral oil-based hydraulic fluids HL or HM type, according to ISO 6743-4. With this kind of fluids, use NBR seals type (code N). With HFDR fluids type (phosphate esters) use FPM seals (code V).

For the use of other fluid types such as HFA, HFB, HFC, please consult our technical department.

Using fluids at temperatures higher than 80 °C causes a faster degradation of the fluid itself and of the seals characteristics.

The fluid must be preserved in its physical and chemical characteristics.

### 4 - OVERALL AND MOUNTING DIMENSIONS

