

Part number:

HYDROMA

HYDRAULICKÉ SYSTÉMY

**HIDROMA
SYSTEMS**

UKŁADY HYDRAULICZNE

HYDROMA

ГИДРАВЛИЧЕСКИЕ СИСТЕМЫ

**MASSIMA PRESSIONE, DIRETTE, OTTURATORE DIFFERENZIALE
DIRECT, DIFFERENTIAL PISTON RELIEF**

VSDC-50

05.12.01 - X - Y - Z

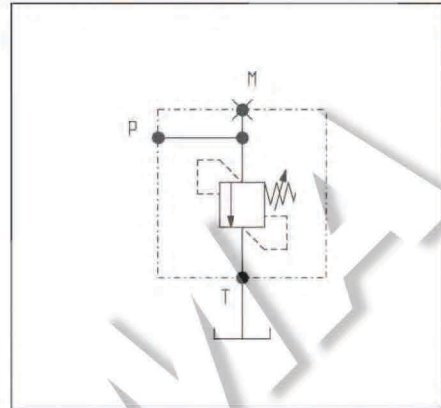
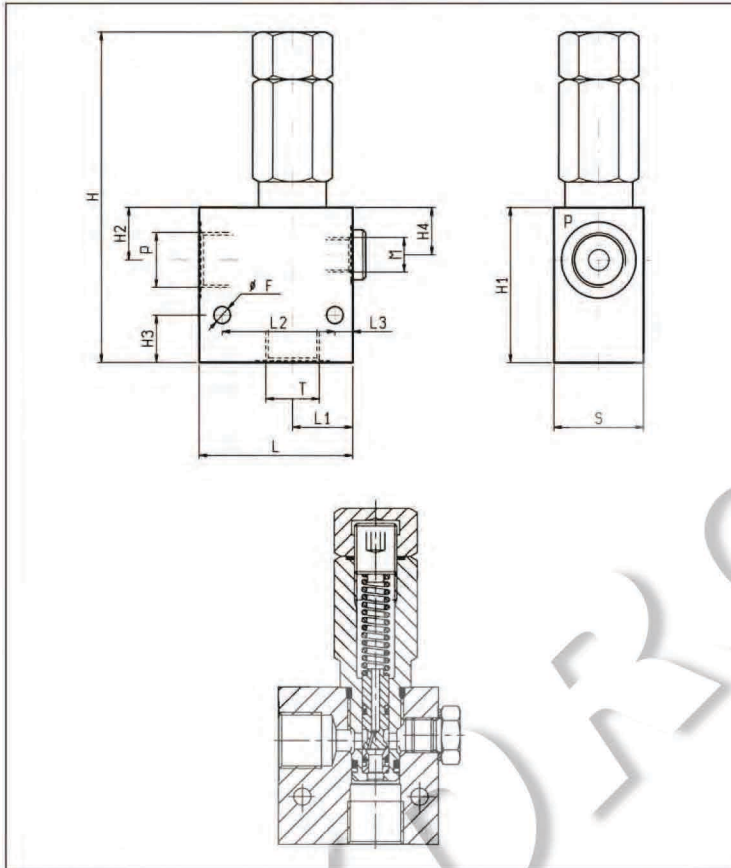

DATI TECNICI / TECHNICAL DATA

Pressione di lavoro max. 350 bar
Max. working pressure

Portata massima vedi diagramma
Flow see performance graph

35	8	44	30	60	18	18	20	59	126	6.5							1/2	0.62
35	7	44	23.5	60	20	8	20	49	116	6.5							3/8	0.58
S	L3	L2	L1	L	H4	H3	H2	H1	H	F							Y	Pressing Weight kg

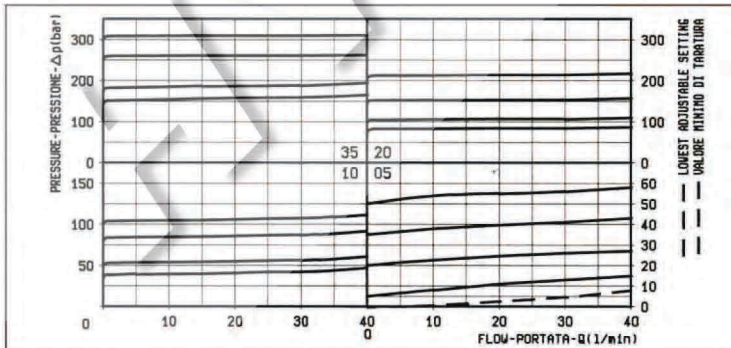

X	REGOLAZIONI ADJUSTMENTS	
03	vite esterna esagono incassato leakproof hex. socket screw	
	cappello per piombatura sealing cap codice / ordering code 03.05.01.001	

Z	MOLLE / SPRINGS				
	Campo taratura min - max bar Adj. press. range bar	Incremento press. bar / giro vite Press. increase bar / turn	Taratura standard bar (Q = 5 l/min) Std. setting bar (Q = 5 l/min)	Cod. ordinazione Ordering code	Colore Colour
05	5-50	15	50	03.51.01.077	nero black
10	30-100	30	100	03.51.01.076	blu blue
20	60-210	60	200	03.51.01.075	verde green
35	100-350	100	350	03.51.01.059	giallo yellow

Y	ATTACCHI / PORT SIZE	
	P-T	M
02	G 3/8	G 1/4
03	G 1/2	G 1/4