

Part number:

HYDROMA

HYDRAULICKÉ SYSTÉMY

**HIDROMA
SYSTEMS**

UKLADY HYDRAULICZNE

HYDROMA

ГИДРАВЛИЧЕСКИЕ СИСТЕМЫ

Check, poppet type

Common cavity, Size 12

VUCN-12A

04.31.28.00.57 - Z

RE 18318-91

Edition: 01.2021

Replaces: 09.2020



Description

When pressure at 1 rises above the spring bias pressure, the poppet is lifted and flow allowed from 1 to 2. The valve is closed (checked) from 2 to 1. Precision machining and hardening processes allow virtually leak-free performance in the checked condition.

Technical data

Max. operating pressure	350 bar (5000 psi)
Max. flow	120 l/min (32 gpm)
Max. internal leakage	5 drops/min.
Fluid temperature range	-30 to 100 °C (-22 to 212 °F)
Installation torque	180 - 200 Nm (133 - 148 ft-lbs)
Weight	0.18 kg (0.4 lbs)
MTTFD	150 years see RE 18350-51
Cavity	CA-12A-2N (see data sheet 18325-70)
Lines bodies and standard assemblies	Please refer to section "Hydraulic integrated circuit" or consult factory
Seal kit ¹⁾	Code: RG12A2010520100 material no: R901111377
Fluids	Mineral-based or synthetics with lubricating properties at viscosities of 5 to 800 mm ² /s (cSt)
Recommended degree of fluid contamination	Nominal value max. 10µm (NAS 8) / ISO 4406 20/18/15
Installation position	No restrictions
Other Technical Data	See data sheet 18350-50

¹⁾ Only external seals for 10 valves

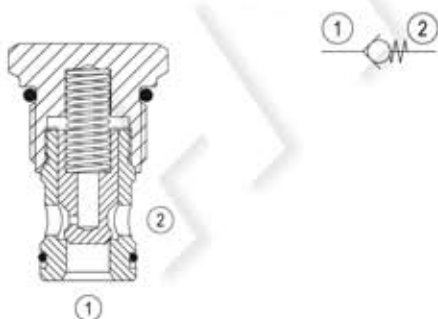

Characteristic curve

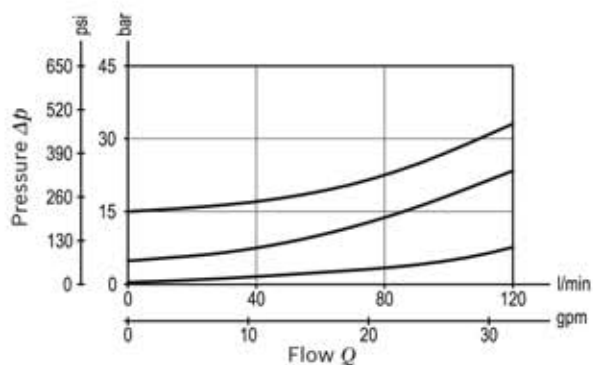

Ordering code

04.31.28.00	57	Z	00	*
-------------	----	---	----	---

Series O/A to L
unchanged performances and dimensions

Check, poppet type

Version and options standard

57 Common cavity, Size 12

SPRINGS	
Cracking pressure bar (psi)	
00	1 (15)
05	5 (75)
08	8 (115)
15	15 (220)

Preferred types

Type	Material number
043128005700000	R901106613
043128005705000	R901106614
043128005708000	R930000490
043128005715000	R901106615

Type	Material number

Dimensions

