

Part number:



CHM5

PILOT OPERATED CHECK VALVE

SERIES 11

MODULAR VERSION ISO 4401-05

p max 350 bar
Q max 120 l/min

MOUNTING INTERFACE

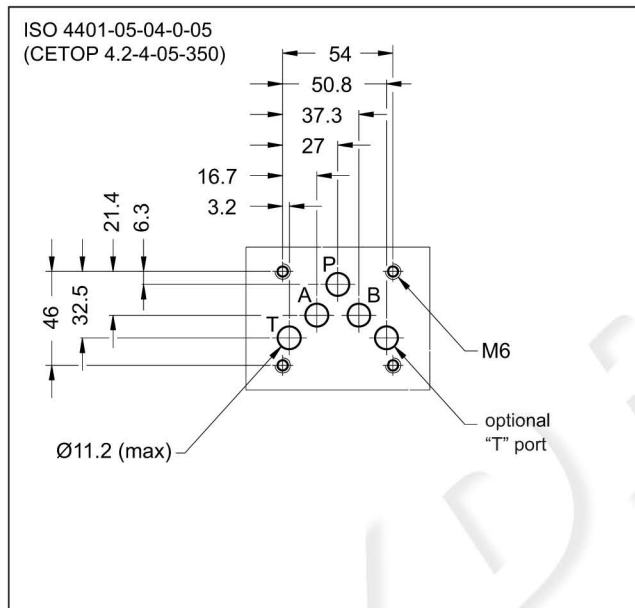

OPERATING PRINCIPLE

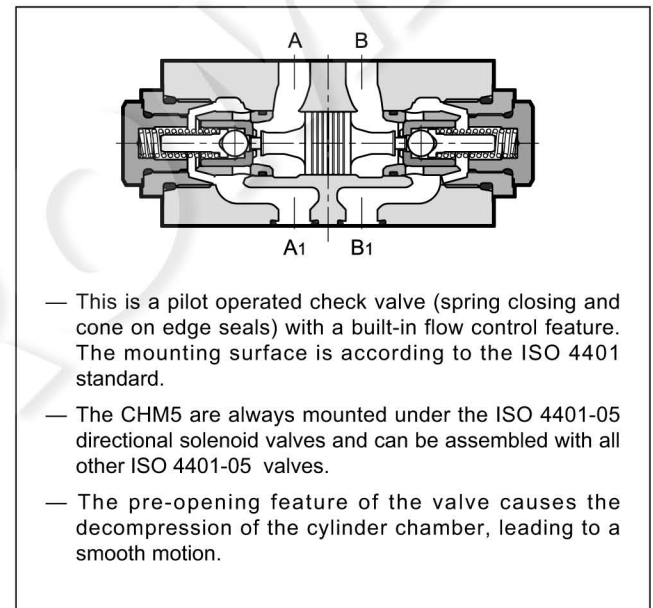

PERFORMANCES

(measured with mineral oil of viscosity 36 cSt at 50°C)

Maximum operating pressure	bar	350
Maximum flow rate	l/min	120
Decompression ratio		14,9:1
Piloting ratio		2,3:1
Check valve cracking pressure	bar	2
Ambient temperature range	°C	-20 / +60
Fluid temperature range	°C	-20 / +80
Fluid viscosity range	cSt	10 ÷ 400
Recommended viscosity	cSt	25
Fluid contamination degree	According to ISO 4406:1999 class 20/18/15	
Mass: CHM5-D	kg	2,2
CHM5-SA and CHM5-SB		1,9

HYDRAULIC SYMBOLS

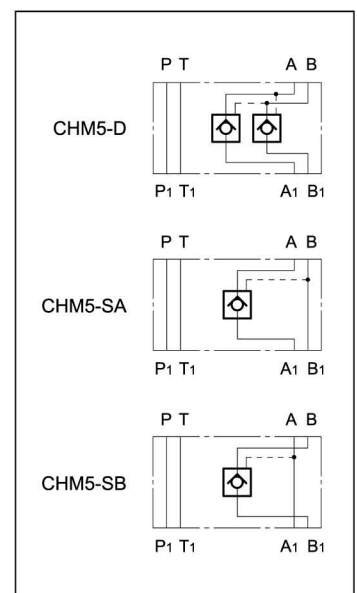

1 - IDENTIFICATION CODE

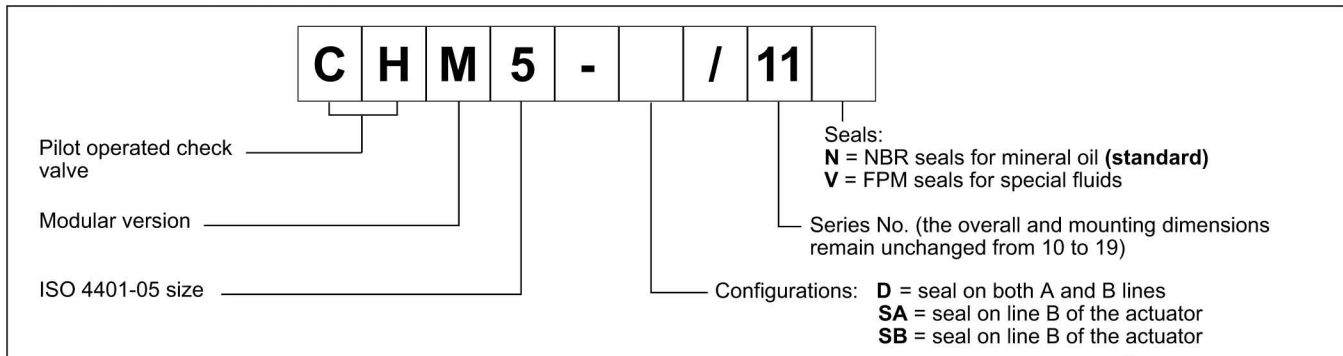

2 - CHARACTERISTIC CURVES (obtained with viscosity of 36 cSt at 50°C)

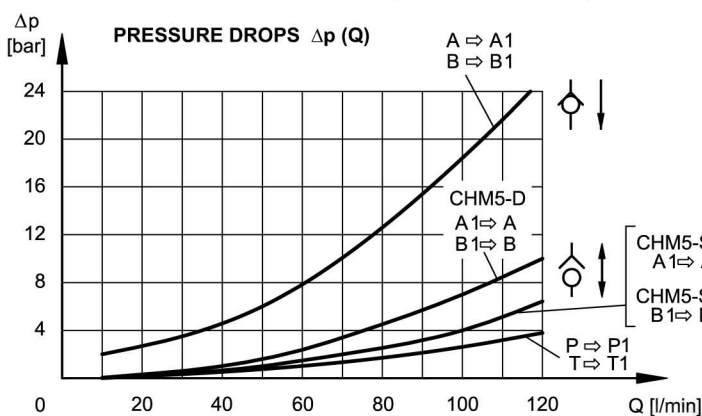

3 - HYDRAULIC FLUIDS

Use mineral oil-based hydraulic fluids HL or HM type, according to ISO 6743-4. For these fluids, use NBR seals (code N). For fluids HFDR type (phosphate esters) use FPM seals (code V).

For the use of other kinds of fluid such as HFA, HFB, HFC, please consult our technical department.

Using fluids at temperatures higher than 80 °C causes a faster degradation of the fluid and of the seals characteristics. The fluid must be preserved in its physical and chemical characteristics.

4 - OVERALL AND MOUNTING DIMENSIONS

