

Part number:

**006-10065a**

**HYDROMA**

HYDRAULICKÉ SYSTÉMY

**HIDROMA  
SISTEMS**

UKŁADY HYDRAULICZNE

**HYDROMA**

ГИДРАВЛИЧЕСКИЕ СИСТЕМЫ

**FLOW CONTROL VALVES  
HOSE BURST PROTECTION INSERT-TYPE**

**VP-N-H**

**VP-N-M**

**OD.41.03.03 - Y - 00**

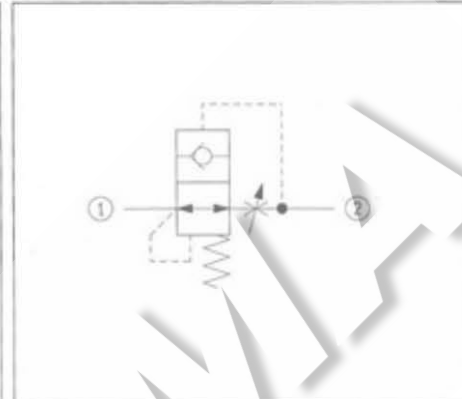
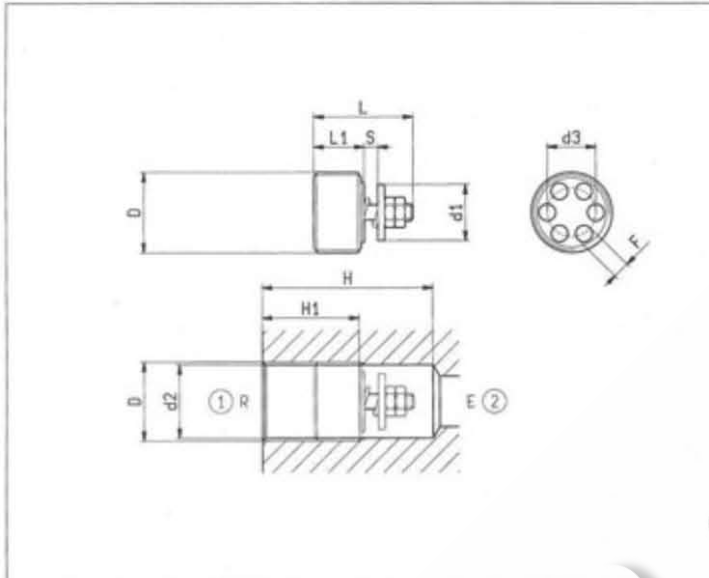

**TECHNICAL DATA**

Maximum Operating Pressure 350 bar

Rated Flow see table

Fluids - Temperatures page 7.01.040

Testing Conditions - Seals page 7.01.040

Filtration : 25 µm nominal or better page 7.01.050

Available on request: orifice in the washer, ensuring a slow descent of the load with valve in closed position. Orifice diameter has to be specified when ordering.

**IMPORTANT:** VPN-M (METRIC THREAD) are not available from stock and not included in our standard price list. Please contact our Sales Department for any information.

17	30.5	38	54	6	16	25	18.5	7	ZCH004	10±2	150	M27x2	27	42
12	25	30	45	4.5	13	20.5	15	7	ZCH003	4±2	80	M22x1.5	22	20
12	25	30	45	4.5	13	18.5	15	7	ZCH003	4±2	80	M20x1.5	20	20
10.5	21	26	37	3.5	10.5	16.5	12.5	5.5	ZCH002	3±1	50	M18x1.5	18	10
10.5	21	26	37	3.5	10.5	14.5	12.5	5.5	ZCH002	3±1	50	M16x1.5	16	10
8	17.5	22	33	2.4	8.5	12.5	9.5	5.5	ZCH001	2±1	25	M14x1.5	14	5
21	40	46	70	7	20	30.75	24	8	ZCH006	15±2	220	G 1	05	96
15.5	30.5	38	54	6	16	24.5	18.5	7	ZCH004	10±2	150	G 3/4	04	42
11	25	30	45	4.5	13	19	15	7	ZCH003	4±2	80	G 1/2	03	20
9.5	21	26	37	3.5	10.5	15.25	12.5	5.5	ZCH002	3±1	50	G 3/8	02	10
8	17.5	22	33	2.4	8.5	11.75	9.5	5.5	ZCH001	2±1	25	G 1/4	09	5
L1	L	H1	H	F	d3	d2	d1	ch1	TIGHTENING TOOL Ordering code	TIGHTENING TORQUE Nm	Q l/min	D	Y	Weight Kg

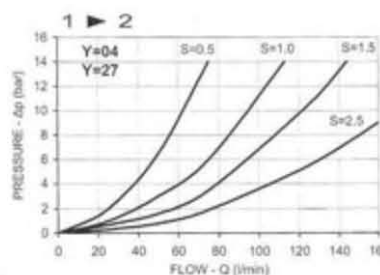
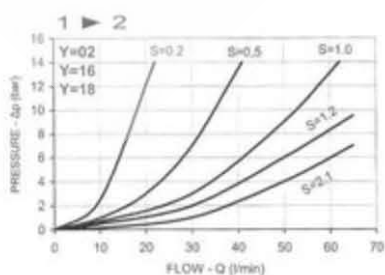
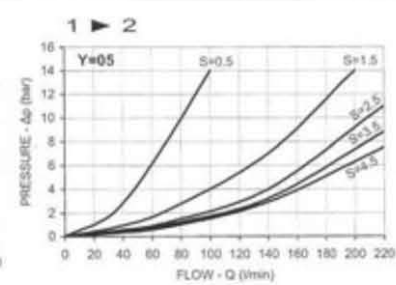
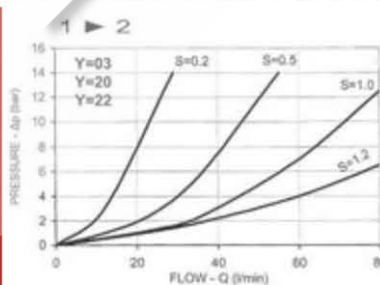
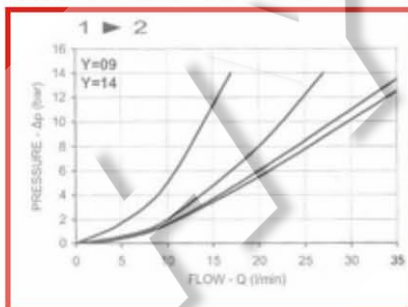



FLOW CONTROL VALVES  
HOSE BURST PROTECTION INSERT-TYPE

VP-N-H

VP-N-M

OD.41.03.03 - Y - 00

## DESCRIPTION - OPERATION

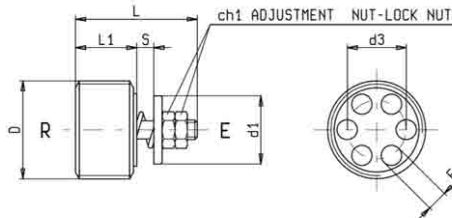

These valves can block flow from an actuator if the descent speed of the load exceeds the medium acceptable speed, for example in case of hose failure. Flow between system and actuator is normally allowed, but the valve closes and instantly shuts off flow from the actuator if a line breaks and setting of the valve (BLOCKING FLOW) is exceeded. These valves are designed to be mounted as close as possible to the actuator which has to be controlled, either screwed directly into the actuator or into an in-line manifold.

## FEATURES - RATINGS

Maximum Operating Pressure

350 bar

Rated Flow

see table

- Fluids - Temperatures - Testing Conditions - Seals : page 7.01.04
- Filtration : 25  $\mu\text{m}$  nominal or better, see page 7.01.05
- Available on request : orifice in the washer, ensuring a slow descent of the load with valve in closed position. Orifice diameter has to be specified when ordering.
- **IMPORTANT** : VPN-M ( METRIC THREAD ) are not available from stock and not included in our standard price list. Please contact our Sales Department for any information.

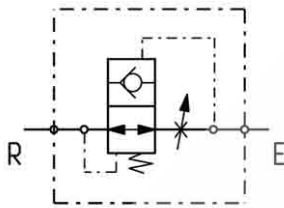
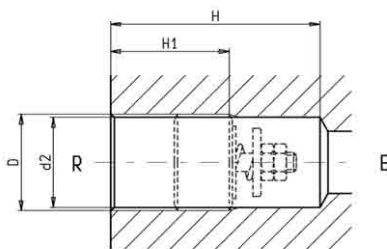

L1	L	H1	H	F	d3	d2	d1	ch1	TIGHTENING TOOL Ordering code	TIGHTENING TORQUE Cartridge	WEIGHT Kg	FLOW MAX. l/min	D	Y
8	17.5	22	33	2.4	8.5	11.75	9.5	5.5	ZCH001	2 $\pm$ 1 Nm	0.005	25	G 1/4	09
9.5	21	26	37	3.5	10.5	15.25	12.5	5.5	ZCH002	3 $\pm$ 1 Nm	0.010	50	G 3/8	02
11	25	30	45	4.5	13	19	15	7	ZCH003	4 $\pm$ 2 Nm	0.020	80	G 1/2	03
15.5	30.5	38	54	6	16	24.5	18.5	7	ZCH004	10 $\pm$ 2 Nm	0.042	150	G 3/4	04
21	40	46	70	7	20	30.75	24	8	ZCH006	15 $\pm$ 2 Nm	0.096	220	G 1	05
8	17.5	22	33	2.4	8.5	12.5	9.5	5.5	ZCH001	2 $\pm$ 1 Nm	0.005	25	M14x1.5	14
10.5	21	26	37	3.5	10.5	14.5	12.5	5.5	ZCH002	3 $\pm$ 1 Nm	0.010	50	M16x1.5	16
10.5	21	26	37	3.5	10.5	16.5	12.5	5.5	ZCH002	3 $\pm$ 1 Nm	0.010	50	M18x1.5	18
12	25	30	45	4.5	13	18.5	15	7	ZCH003	4 $\pm$ 2 Nm	0.020	80	M20x1.5	20
12	25	30	45	4.5	13	20.5	15	7	ZCH003	4 $\pm$ 2 Nm	0.020	80	M22x1.5	22
17	30.5	38	54	6	16	25	18.5	7	ZCH004	10 $\pm$ 2 Nm	0.042	150	M27x2	27

PRESSURE DROP R-E

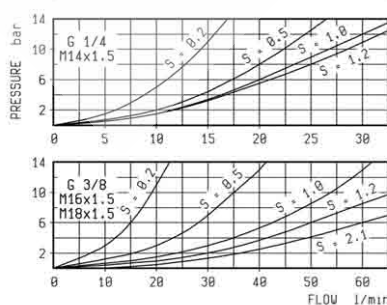

PRESSURE DROP R-E

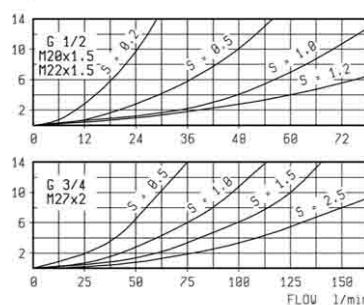

PRESSURE DROP R-E

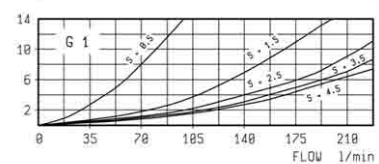

## FLOW CONTROL VALVES HOSE BURST PROTECTION INSERT-TYPE

VP-N-H

VP-N-M

### HOW TO CALCULATE BLOCKING FLOW AND PREVENT UNDESIRABLE OPERATION

The BLOCKING FLOW of a hose burst valve has to be calculated multiplying the regulated flow from the actuator by a factor between 1,5 (manual directional control valve) and 2 (solenoid operated directional control valve). This is to prevent undesired operation, since these valves are sensitive to any transient flow above setting. In systems where very big cylinders or very high loads are used, the only way to prevent undesired operation is to insert a fixed orifice in the circuit. Flow through the orifice at the maximum load conditions must be higher than regulated flow from the actuator but lower than blocking flow of the hose burst valve. The orifice has to be placed in a part of the circuit different from the line which has to be protected by the hose burst valve, such as the line to tank (see example B); obviously at the minimum load conditions, the descent of the load could be very slow.

### SETTING OF THE VALVE

- Block valve body in a clamp, paying attention not to damage external thread.
- Screw the locknut completely out.
- Screw the nut down until washer reaches the desired DISTANCE TO ADJUST S (see diagrams below).
- Screw the locknut down while keeping the nut blocked with another wrench and tighten at 2-3 Nm torque.

### INTERNAL LEAKAGE IN CLOSED POSITION

Sealing parts are superfinished and leakproof, but leakage through the external thread has to be considered normal and does not affect correct operation, since the function of this valve is to prevent the load from falling down in case of a line break, but not to hold it for long time in the same position. This leakage anyway does not exceed 500 cm<sup>3</sup>/min at 350 bar with 46 cSt oil.

### APPLICATION EXAMPLES :

#### EXAMPLE A

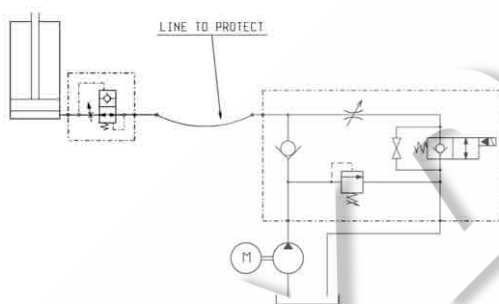

BLOCKING FLOW E-R

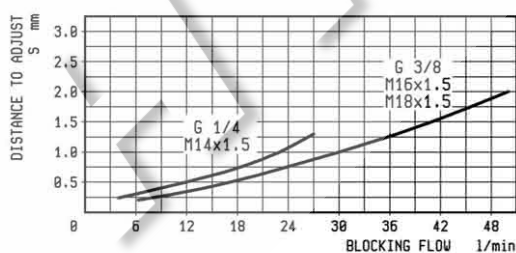

#### EXAMPLE B

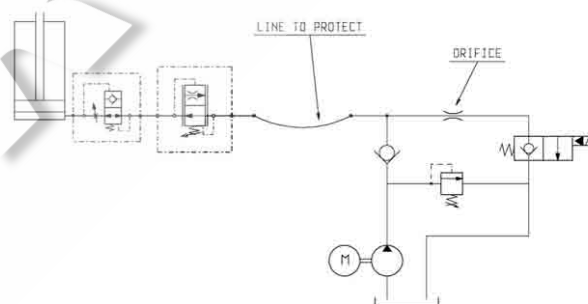

BLOCKING FLOW E-R

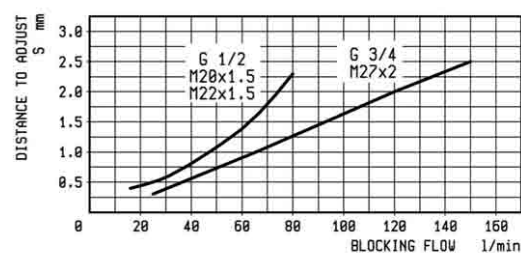

BLOCKING FLOW E-R

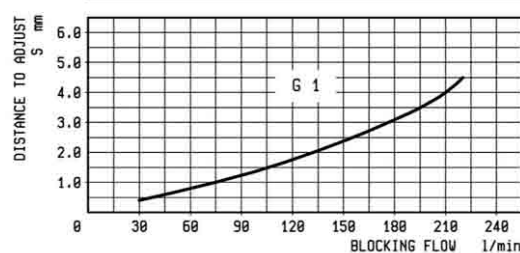

N.B: For any fixed distance to adjust "S" BLOCKING FLOW can have  $\pm 10\%$  fluctuations