

Part number:

**HYDROMA**

HYDRAULICKÉ SYSTÉMY

**HIDROMA  
SYSTEMS**

UKŁADY HYDRAULICZNE

**HYDROMA**

ГИДРАВЛИЧЕСКИЕ СИСТЕМЫ

## Dual counterbalance

A-VBSO-DE-30-FC1

08.44.30 - X - Y - Z

**RE 18307-60**

Edition: 02.2022

Replaces: 05.2017



### Description

It provides static and dynamic control of load by regulating the flow IN and OUT of the actuator, through ports C1 and C2. This valve module includes 2 sections, each one composed by a check and a relief valve pilot assisted by pressure in the opposite line: the check section allows free flow into the actuator, then holds the load against reverse movement; with pilot pressure applied at the line across, the pressure setting of the relief is reduced in proportion to the stated ratio until opening and allowing controlled reverse flow. Back-pressure at V1 or V2 is additive to the pressure setting in all functions. For better safety and compact assembly, the C2 port is gasket mounted directly on the actuator.

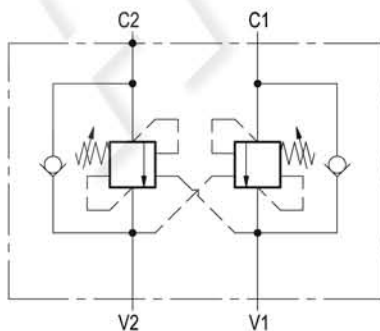

### Technical data

Max. operating pressure	410 bar (5945 psi)
Max. flow	60 l/min. (16 gpm)
Weight	see "Dimensions"
Manifold material	Zinc plated steel
Flange seal kit <sup>1)</sup>	E00000000000056 (R930060579)
Fluid	Mineral oil (HL, HLP) according DIN 51524
Fluid temperature range	-30 °C to 100 (-22 to 212 °F)
Viscosity range	5 to 800 mm <sup>2</sup> /s (cSt)
Recommended degree of fluid contamination	Class 19/17/14 according to ISO 4406
MTTFd	150 years see data sheet 18350-51
Other technical data	see data sheet 18350-50
Relief setting:	at least 1.3 times the highest expected load.

Note: for applications outside these parameters, please consult us.

<sup>1)</sup> Seals for 10 valves.

### Characteristic curve

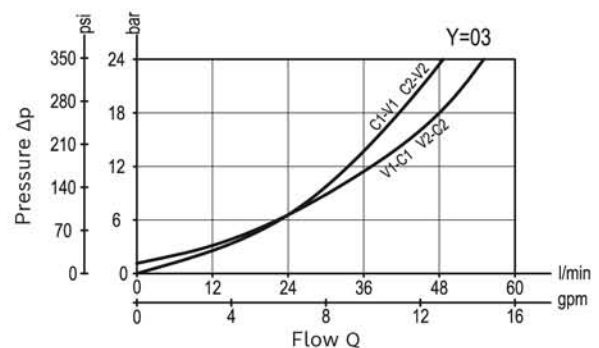

Ordering code

08.44.30	X	Y	Z
----------	---	---	---

Dual counterbalance

Pilot ratio

03 4.2 : 1

Port sizes	V1 - V2 - C1	C2	M
02	G 3/8	∅ 9 (0.35)	G 1/4
03	G 1/2	∅ 9 (0.35)	G 1/4

	SPRINGS		
	Adj. pressure range bar (psi)	Pres. increase bar/turn (psi/turn)	Std. setting Q=5 (l/min) bar (psi)
20	60-210 (870-3000)	63 (914)	200 (2900)
35	180-350 (2610-5000)	138 (2001)	350 (5000)

Pressure setting up to 410 bar: code on request.

Tamper resistant cap ordering code 11.04.23.002  
Mat. no. R930000752



Preferred types

Type	Material number
084430030220000	R930003428
08443003023500B	R930003429

Type	Material number
08443003033500A	R930003432

Dimensions

