

Part number:

HYDROMA

HYDRAULICKÉ SYSTÉMY

**HIDROMA
SYSTEMS**

UKŁADY HYDRAULICZNE

HYDROMA

ГИДРАВЛИЧЕСКИЕ СИСТЕМЫ

**CONTROLLO MOVIMENTO, SERIE "SICN"
SERIES "SICN" MOTION CONTROL**

VAA-B-SICN-ST-50

05.71.44 - X - Y - Z

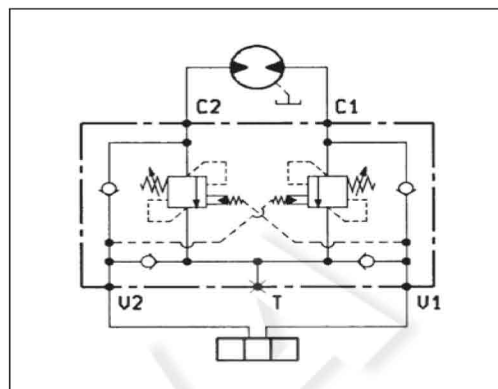
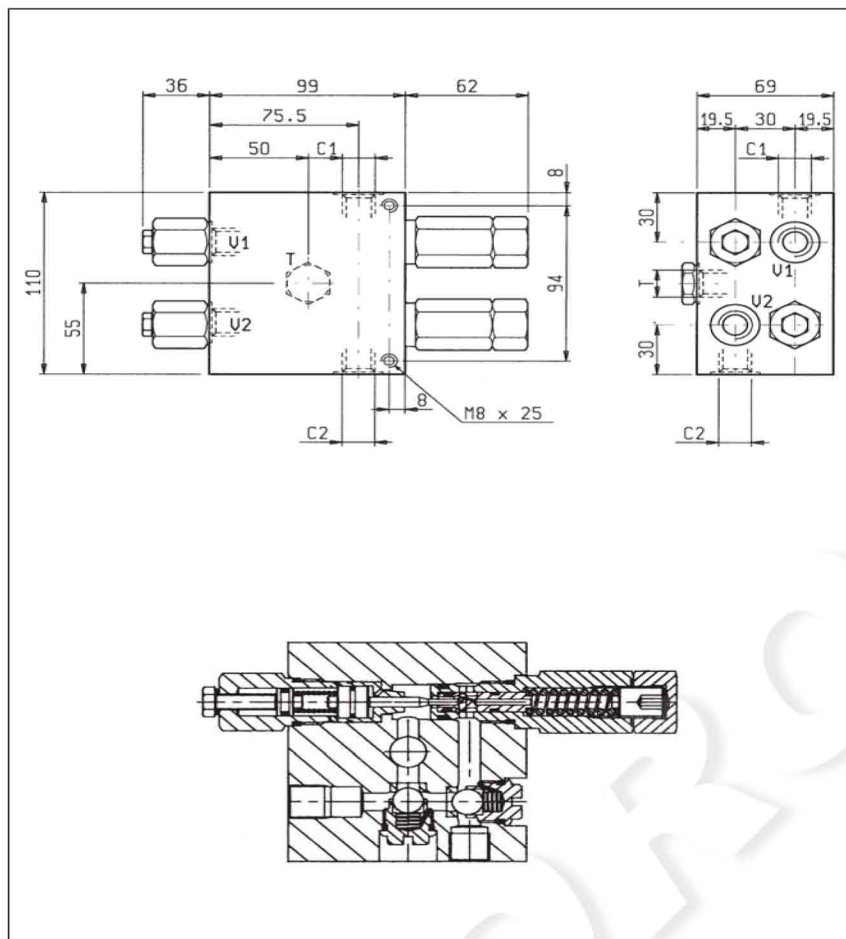

DATI TECNICI / TECHNICAL DATA

Pressione max. Max. pressure	350 bar
Portata max. Flow max.	40 l/min
Taratura della valvola: almeno 1.3 volte superiore alla pressione indotta dal carico Pressure setting: at least 1.3 times the load induced pressure	
Peso Weight	3.48 kg

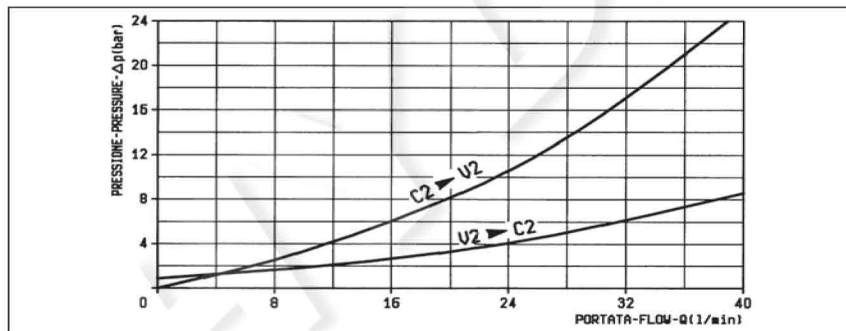

X	RAPPORTO DI PILOTAGGIO PILOT RATIO
37	9,1 : 1

Z	MOLLE / SPRINGS				
	Campo taratura min - max bar Adj. press. range bar	Incremento press. bar / giro vite Press. increase bar / turn	Taratura standard bar (Q = 5 l/min) Std. setting bar (made at = 5 l/min)	Cod. ordinazione Ordering code	Colore Colour
20	60-180	60	150	03.51.01.075	verde green
35	100-350	100	150	03.51.01.059	giallo yellow

Y	ATTACCHI / PORT SIZE
	V1-V2-C1-C2-T
02	G 3/8