

Part number:

HYDROMA

HYDRAULICKÉ SYSTÉMY

**HIDROMA
SYSTEMS**

UKŁADY HYDRAULICZNE

HYDROMA

ГИДРАВЛИЧЕСКИЕ СИСТЕМЫ

Tipo / Type

FPBN-*.*.*

Sez./Section

L

Pag./Page

051/1

**Valvola regolatrice di flusso bidirezionale
In-line double acting flow control valve**

Rev.02-2020/10

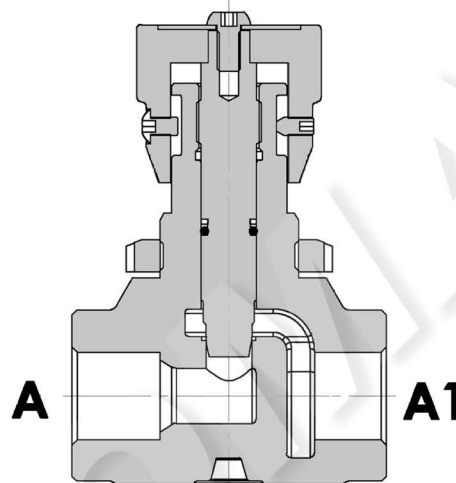
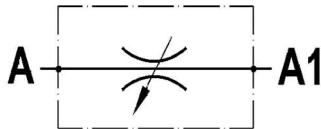

SPECIFICHE TECNICHE

Materiali: corpo in ghisa. Parti interne in acciaio.

Portata max.: fino a 100 l/min

Pressione max.: 400 bar, vedasi tabella pag.02

TECHNICAL SPECIFICATIONS

Materials: body is cast-iron made. Internal parts are steel made.

Rated flow: up to 100 l/min

Max. pressure: 400 bar, see data sheet page 02

DIAGRAMMA PERDITE DI CARICO PRESSURE DROP CURVES

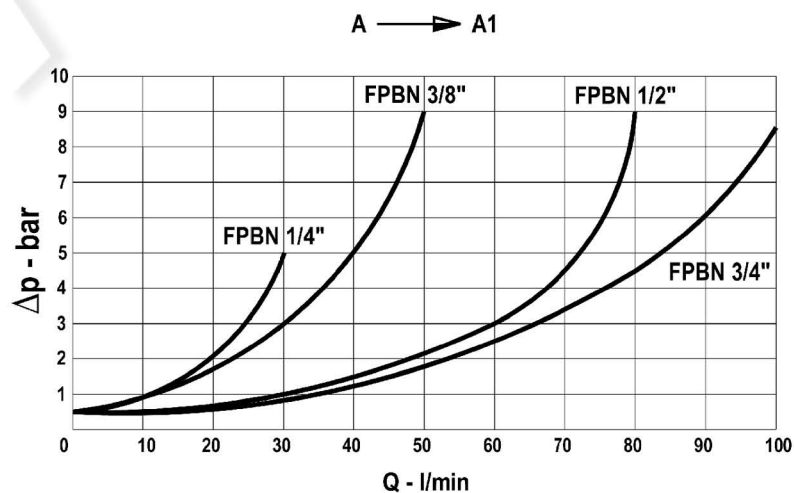

**Valvola regolatrice di flusso bidirezionale
In-line double acting flow control valve**

Rev.02-2020/10

VITE DI FERMO: COPPIA MASSIMA
DI SERRAGGIO – 0,8 N/m

LOCKING SCREW: MAX. INSTALLATION
TORQUE – 0,8 N/m

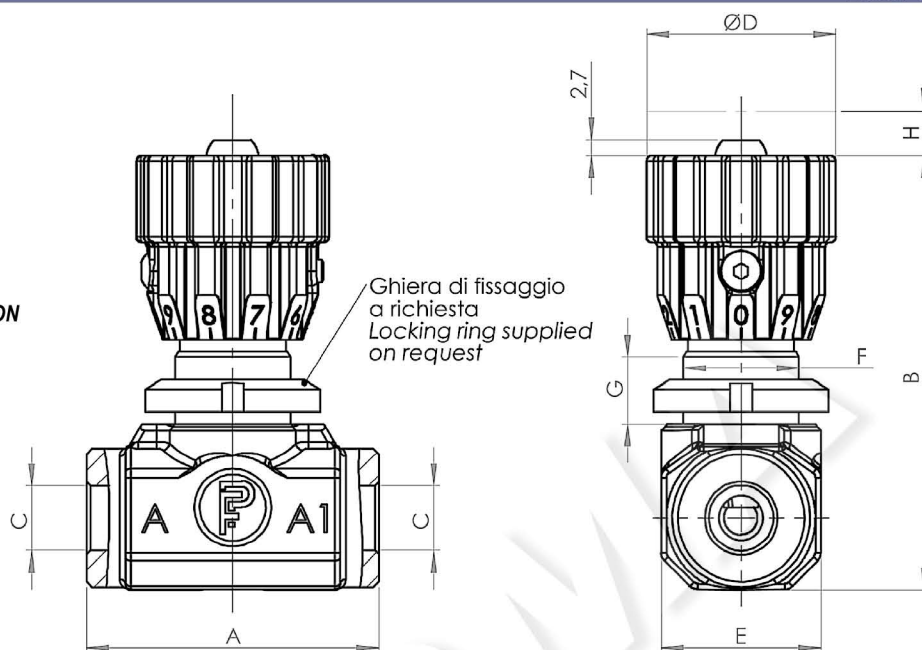

Ghiera di fissaggio
a richiesta
Locking ring supplied
on request

TIPO TYPE	PORTATA MAX. MAX FLOW	PRESSIONE MAX. MAX PRESSURE	A	B	C	D	E	F	G	H	PESO WEIGHT
	L/MIN	BAR	mm	mm	BSPP	mm	mm	mm	mm	mm	Kg
FPBN 1/4"	30	400	53	78	1/4"	35	29	M20X1	13	7.5	0.340
FPBN 3/8"	50	400	53	78	3/8"	35	29	M25X1.5	13	7.5	0.360
FPBN 1/2"	80	400	68	95	1/2"	40	40	M30X1.5	14	8.5	0.810
FPBN 3/4"	100	350	68	95	3/4"	40	40	M35X1.5	14	8.5	0.780

**ISTRUZIONI PER IL
MONTAGGIO A
PANNELLO**

**INSTRUCTIONS FOR
PANEL MOUNTING**

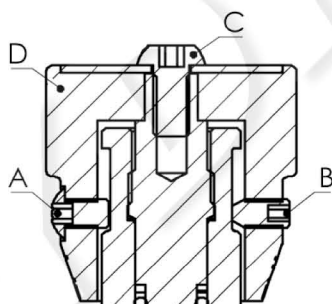

Togliere le viti "A" di fine corsa, "B" di bloccaggio regolazione e "C" di fissaggio pomolo; sfilare il pomolo "D" ed installare la valvola a pannello fissandola con relativa ghiera.
Rimontare nell'ordine inverso i particolari precedentemente smontati.

Remove the screw "A" of limit stop, "B" for blocking and regulation, "C" of handwheel fixing; withdraw the handwheel "D" and install the panel-valve by fixing it with the relative metal ring.
Re-assemble in reversed order the parts previously disassembled.

ESEMPIO DI ORDINAZIONE - ORDERING CODE EXAMPLE

F P B N **1 / 2** **F** *****

1/4 – 1/4" BSPP
3/8 – 3/8" BSPP
* 1/2 – 1/2" BSPP
3/4 – 3/4" BSPP
Conessioni - Port sizes

Guarnizioni – Seals:
V=Viton *
Omettere se BUNA-N – Omit if BUNA-N

F – ghiera di fissaggio – locking ring *
Omettere se non richiesta – omit if not requested