

Part number:

096-10024

HYDROMA

HYDRAULICKÉ SYSTÉMY

**HIDROMA
SYSTEMS**

UKŁADY HYDRAULICZNE

HYDROMA

ГИДРАВЛИЧЕСКИЕ СИСТЕМЫ



RPCE2-*

PILOT OPERATED FLOW CONTROL VALVE WITH ELECTRIC PROPORTIONAL CONTROL

SERIES 51

RPCE2 two-way
RPCE2-*-T3 three-way

SUBPLATE MOUNTING

CETOP 06

p max 250 bar

Q max (see specification table)

OPERATING PRINCIPLE

RPCE2

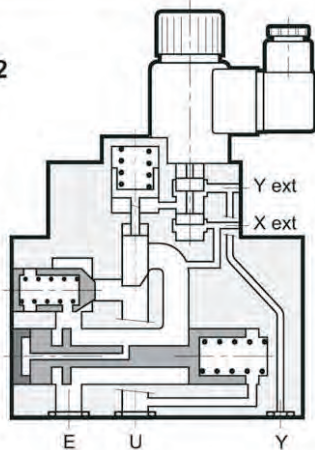

RPCE2-*-T3

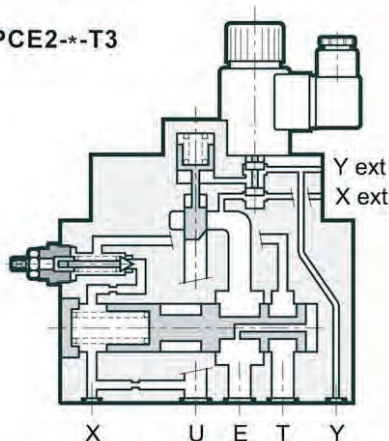

- RPCE2-* valves are two-way or three-way flow control valves with pressure and thermal compensation and electric proportional control with mounting interface in compliance with CETOP standards.
- These valves are normally used for flow rate control in hydraulic circuit branches and for speed control of hydraulic actuators.
- Flow rate can be modulated continuously in proportion to the current supplied to the solenoid.
- The valve can be controlled directly by a current control supply unit or by means of the relative electronic control units which enable optimal valve performance (see par. 12).
- The valves are available in four flow control ranges: three with progressive gain up to 60 l/min and the fourth with differential gain of 35 l/min.
- To ensure correct valve operation, maintain a minimum pilot control flow rate of 2 l/min and minimum pressure of 20 bar.
- Pilot control can be internal, with intake of oil from line E, or external from a line with 1/4" BSP connection on the pilot body.
- Drainage is always external and must be connected directly to the tank without backpressure by means of subplate connection Y (OR \varnothing 35) or by means of a line (1/4" BSP coupling) on the pilot body.
- The three-way version RPCE2-*-T3 allows flow control to the circuit by dumping the exceeding flow to the tank. Maximum pressure in the circuit is limited by means of a manual adjustment relief valve which operates on the compensator pilot.
- RPCE2-*-T3 valve is also available in /M version, which allows, by means of an electric control, to unload the total flow with a minimum pressure drop.

HYDRAULIC SYMBOLS

RPCE2

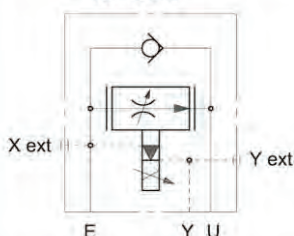

RPCE2-*-T3

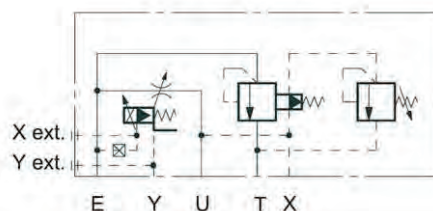

RPCE2-*-T3M

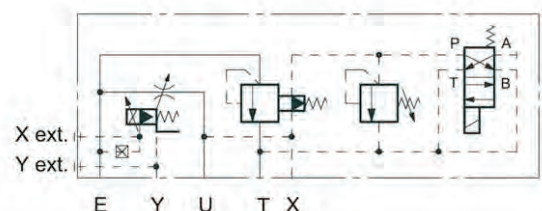

1 - IDENTIFICATION CODES

1.1 - Identification code for two-way valve: RPCE2

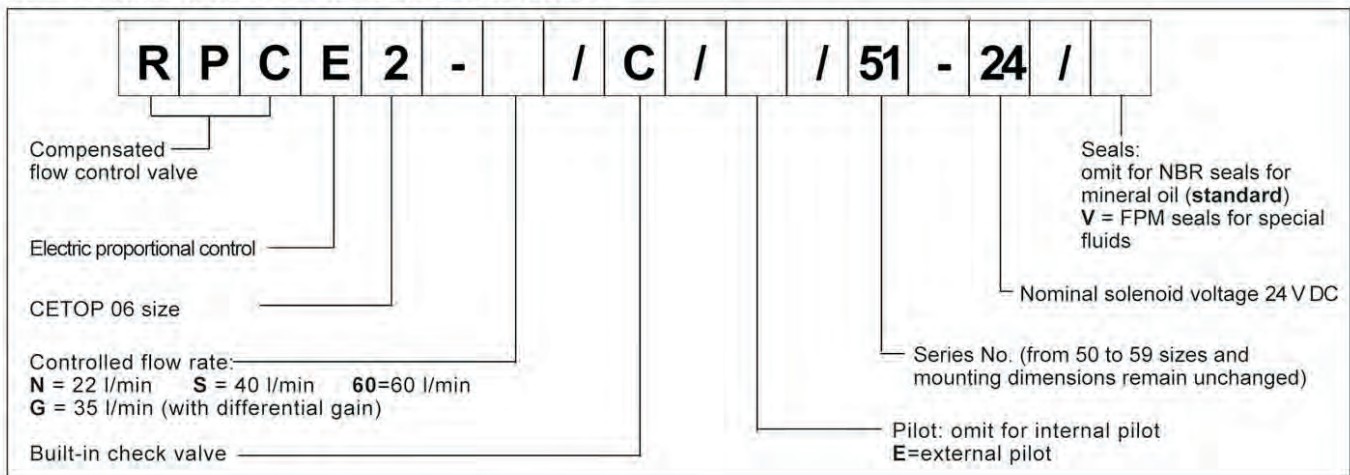

1.2 - Identification code for three-way valve: RPCE2--T3

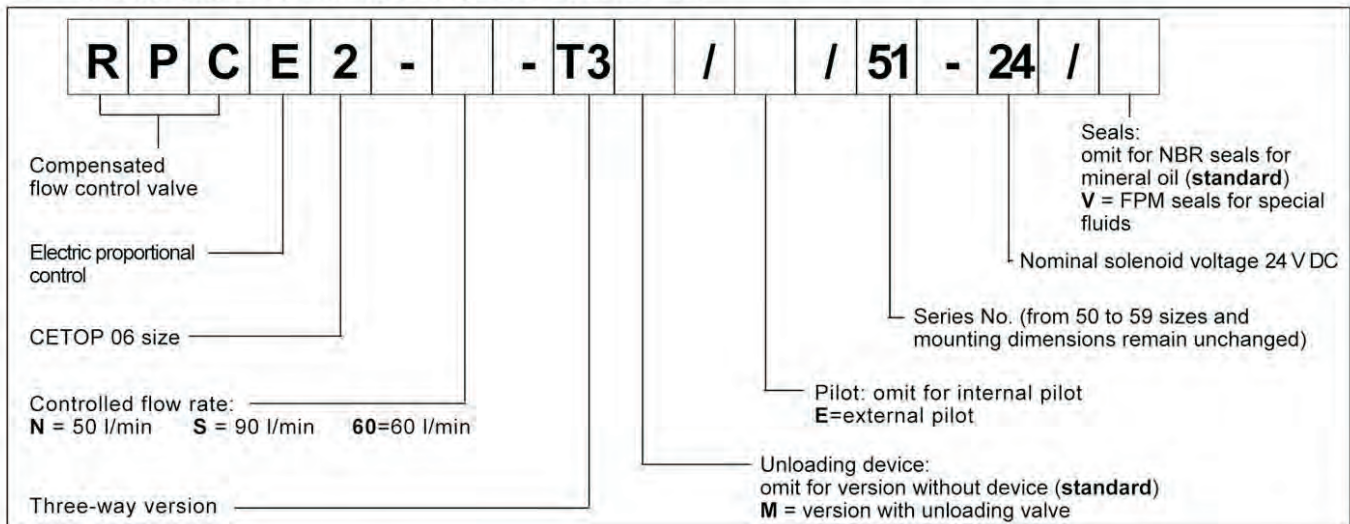

SPECIFICATIONS (obtained with mineral oil with viscosity of 36 cSt at 50°C in conjunction with UEIK-11 electronic control unit)

Maximum working pressure	bar	250	
Minimum Δp across E and U ports	bar	10	
Piloting pressures	min.	20	
	max.	160 (note 1)	
Maximum controlled flow E → U (RPCE2)	l/min.	22 - 35 - 40 - 60	
Maximum controlled flow (RPCE2--T3)	l/min.	50 - 60 - 90	
Minimum controlled flow with P = 100 bar	(versions N, S, 60)	l/min.	0,5
	(version G)	l/min.	0,2
Maximum free reverse flow U → E	l/min.	60 (note 2)	
Step response	see par. 8		
Hysteresis	% of Q max	< 8%	
Repeatability	% of Q max	< ±3%	
Electrical features	see par. 7		
Ambient temperature range	°C	-10 ÷ +50	
Fluid temperature range	°C	-20 ÷ +70	
Fluid viscosity range	cSt	13 ÷ 380	
Recommended viscosity	cSt	25	
Fluid contamination degree	according to NAS 1638 class 7		
Mass	RPCE2 RPCE2--T3	kg	7,2
	RPCE2--T3M	kg	9,0

NOTE 1: Pilot must be external if the valve is used with line pressure over 160 bar.

NOTE 2: Maximum recommended flow U → E through the check valve (only for two-way version)

3 - HYDRAULIC FLUIDS

Use mineral oil-based hydraulic fluids HL or HLP type, according to ISO 6743/3.

For fluids HFD-R type (phosphate esters) use FPM seals (code V).

For the use of other fluid types as HFA, HFB, HFC, please consult our technical department.

Using fluids at temperatures higher than 70°C causes a faster degradation of the fluid and of the seals characteristics.

The fluid must be preserved in its physical and chemical characteristics.

4 - CHARACTERISTIC CURVES (measured with viscosity of 36 cSt at 50°C)

FLOW CONTROL $Q = f(I)$ - 2 way version

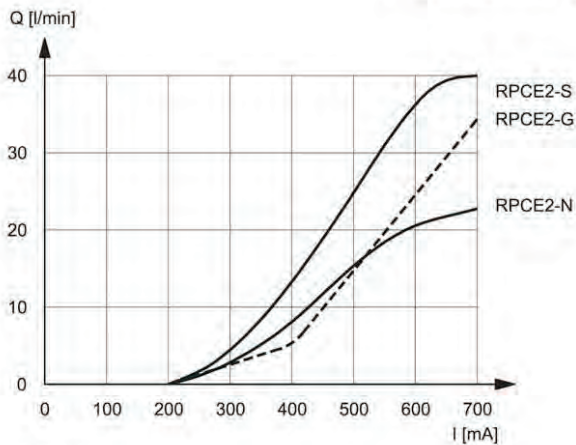

Typical flow control curves for flow rate E → U for N, S and G versions, according to the current supplied to the solenoid.

The RPCE2-G version, featuring differential gain control, is particularly suitable for "FAST-SLOW" flow rate control as it ensures high sensitivity at low flow rates while enabling high flow rates for rapid actuator movement.

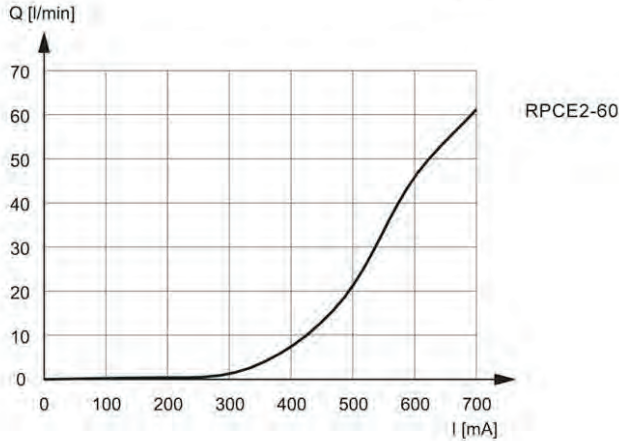

Typical flow control curves for flow rate E → U for RPCE2-60 version, according to the current supplied to the solenoid.

FLOW CONTROL $Q = f(I)$ - 3 way version

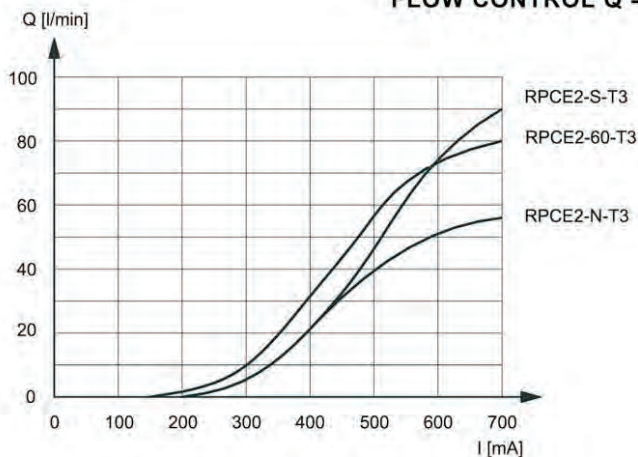

Typical flow control curves for flow rate E → U for N, S, 60 versions, according to the current supplied to the solenoid.

PRESSURE DROP $\Delta p = f(Q)$

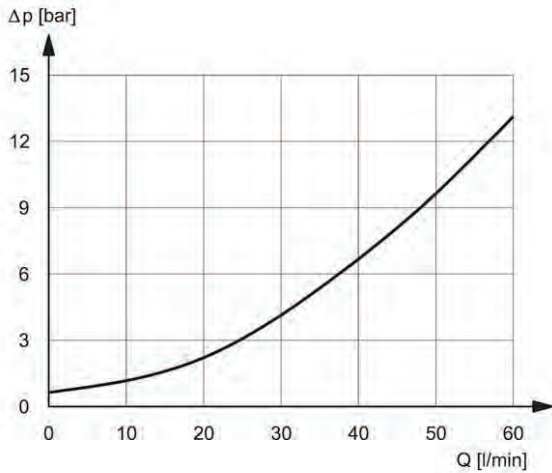

Pressure drops with free flow U → E through check valve (only for two-way RPCE2 valve).

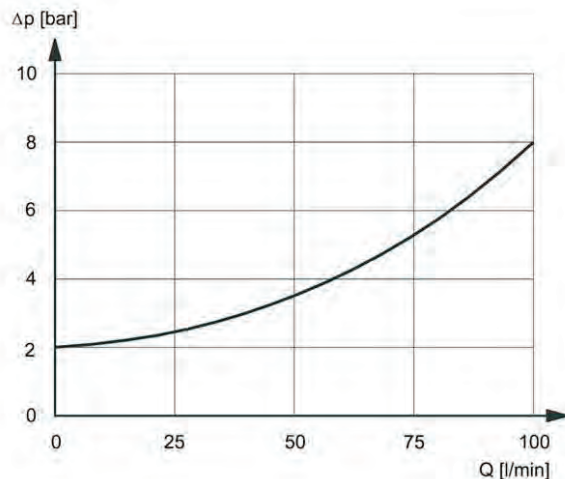

Pressure drops E → T (only for three-way versions)

Curve obtained with unloading electrical control (RPCE2*-T3M)

5 - PRESSURE COMPENSATION

The valves are equipped with two restrictors. The first is an opening which can be adjusted by the proportional solenoid; the second, controlled by the pressure upstream and downstream of the first restrictor ensures constant pressure drop across the adjustable restrictor. In these conditions, the set flow rate value is maintained constant within a tolerance range of $\pm 3\%$ of the set flow rate for maximum pressure variation between the valve inlet and outlet chambers.

6 - THERMAL COMPENSATION

A temperature-sensitive device installed on the flow control element corrects the position and maintains the set flow rate virtually unchanged, also in the case of fluid viscosity variation.

Flow rate variation remains within 2,5% of the set flow rate, for a fluid temperature variation of 10°C.

RPCE2-*

SERIES 51

7 - ELECTRICAL CHARACTERISTICS

Proportional solenoid

The proportional solenoid comprises two parts: tube and coil.

The tube, screwed to the valve body, contains the armature which is designed to maintain friction to a minimum thereby reducing hysteresis.

The coil is mounted on the tube secured by means of a lock nut and can be rotated through 360° depending on installation clearances.

NOMINAL VOLTAGE	V DC	20
COIL RESISTANCE (at 20°C)	Ω	18,5
CURRENT	nominal maximum	0,7 0,82
DUTY CYCLE	100%	
ELECTROMAGNETIC COMPATIBILITY (EMC)	in compliance with 89/336 EEC	
- EMISSIONS	EN 50081-1	
- IMMUNITY	EN 50082-2	
PROTECTION TO ATMOSPHERIC AGENTS (according to IEC 144 standards)	IP 65	

8 - STEP RESPONSE (with mineral oil with viscosity of 36 cSt at 50°C in conjunction with UEIK-11 electronic control unit)

Step response is the time taken for the valve to reach 90% of the set pressure value following a step change of reference signal. The table shows typical response times measured with valves "S" (40 l/min) and with an input pressure of 100 bar.

REFERENCE SIGNAL STEP	0→100%	100%→0	25→75%	75→25%
Step response [ms]	250	120	110	90

9 - INSTALLATION

The RPCE2 valve, both two-way or three-way versions, can be installed in any position without impairing correct operation. Ensure that there is no air in the hydraulic circuit.

Valves are fixed by means of screws or tie rods on a flat surface with planarity and roughness equal to or better than those indicated in the relative symbols. If minimum values are not observed fluid can easily leak between the valve and support surface.

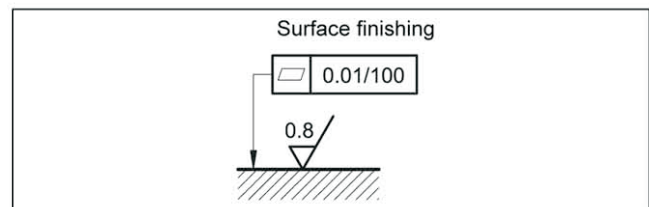

10 - OVERALL AND MOUNTING DIMENSION TWO-WAY VALVE RPCE2

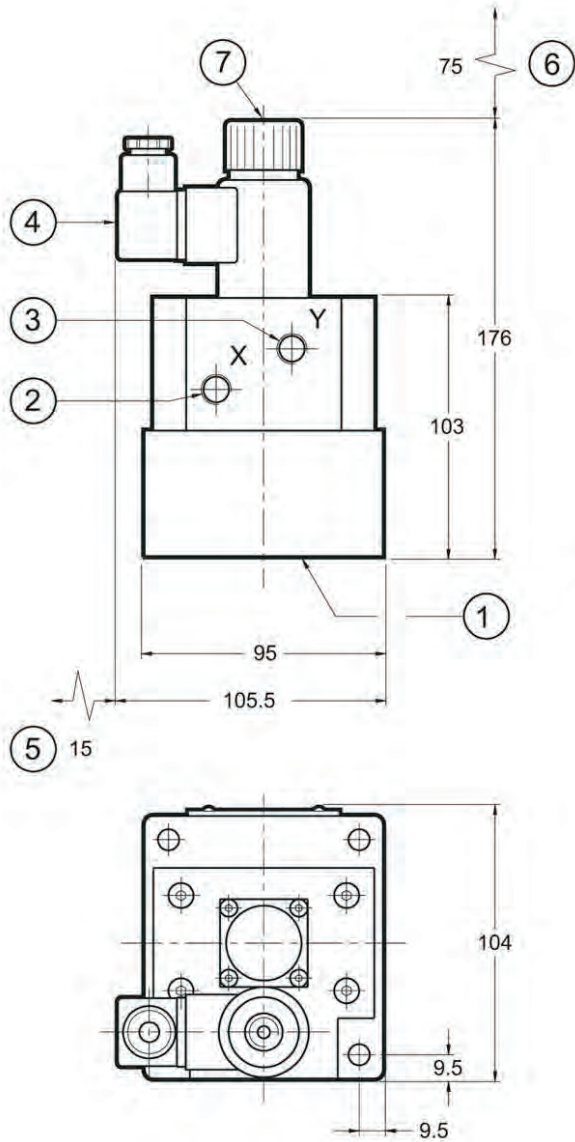

Mounting surface: CETOP 4.5.2-2-06-250

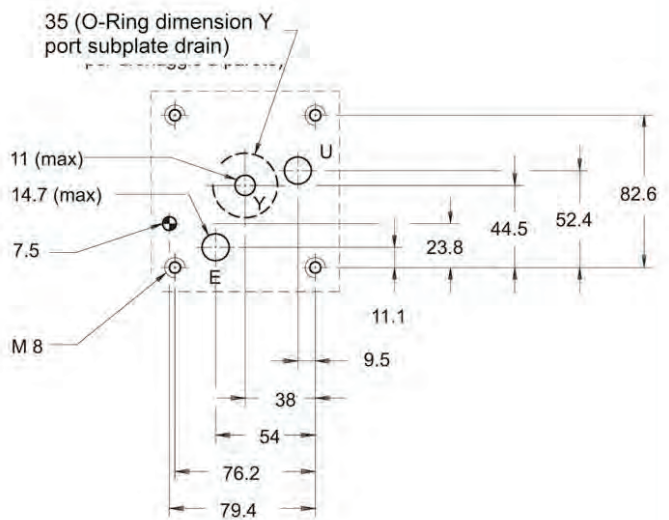

dimensions in mm

Fastening bolts: 4 bolts M8x60
Torque: 20 Nm

1	Mounting surface with sealing rings: 2 OR type 119 1 OR type 2125
2	External pilot port X: 1/4" BSP
3	Drain port Y: 1/4" BSP if mounting interface port is not used
4	DIN 43650 electric connector
5	Connector removal space
6	Coil removal space
7	Manual emergency control

RPCE2-*

SERIES 51

11 - OVERALL AND MOUNTING DIMENSIONS THREE-WAY VALVES RPCE2-*T3 and RPCE2-*T3M

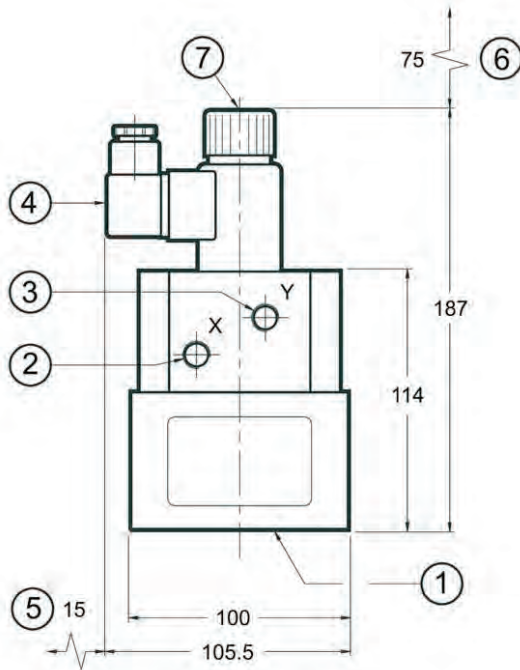

Mounting surface: CETOP 4.5.2-3-06-250

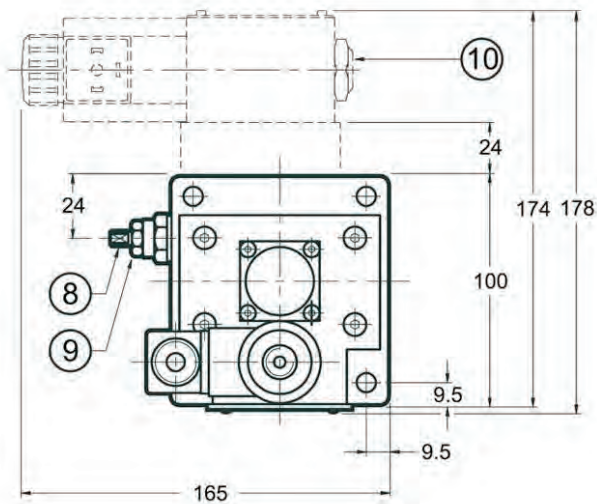
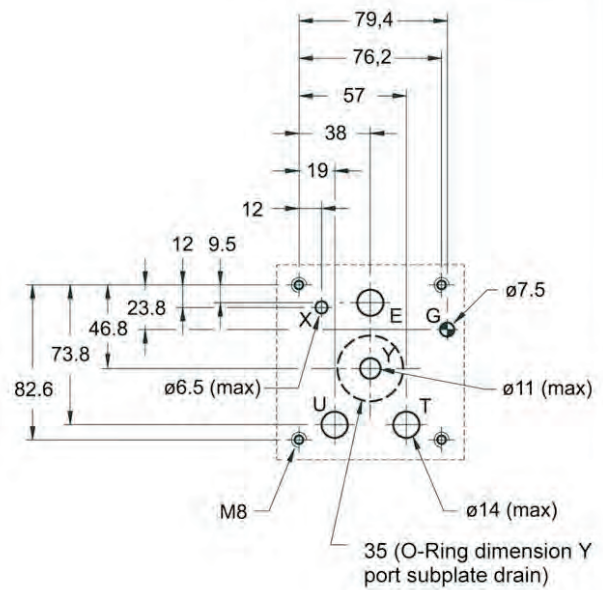

dimensions in mm

Fastening bolts: 4 bolts M8x75
Torque: 20 Nm

1	Mounting surface with sealing rings: 3 OR type 119 1 OR type 2125 1 OR type 109
2	External pilot port X: 1/4" BSP
3	Drain port Y: 1/4" BSP if mounting interface port is not used
4	DIN 43650 electric connector
5	Connector removal space
6	Coil removal space
7	Manual emergency control
8	Pressure relief valve - adjustment screw: square spanner 6 - pressure adjustment range up to 210 bar - default setting: minimum
9	Locking nut: spanner 13
10	Unloading solenoid valve type MD1D-TC (only for version RPCE2 -*T3M) - solenoid valve OFF = flow unloading at minimum pressure - solenoid valve ON = unloading pressure controlled by pressure relief valve 8

RPCE2-*

SERIES 51

12 - ELECTRONIC CONTROL UNITS

EPC-111	plug version	(see cat. 89 110)
EPA-M111	rail mounting DIN EN 50022	(see cat. 89 220)
UEIK-11	Eurocard format	(see cat. 89 300)

13 - SUBPLATES (see catalogue 51 000)

NOTE: The valve must have the Y drain with external pipe when using the subplates listed below.

	Two-way version RPCE2	Three-way version RPCE2-*-T3
Type	PMRPC2-AI4G rear ports	PMRPCQ2-AI4G rear ports
E, U, T ports threading	1/2" BSP	1/2" BSP
X port threading	-	1/4" BSP