

Part number:



RQ-P**
UNLOADING VALVE
(FOR CIRCUITS WITH ACCUMULATOR)
SERIES 42

RQR*-P
FOR REMOTE PILOTING

RQA*-P
WITH INCORPORATED CHECK VALVE

SUBPLATE MOUNTING

HYDRAULIC SYMBOLS

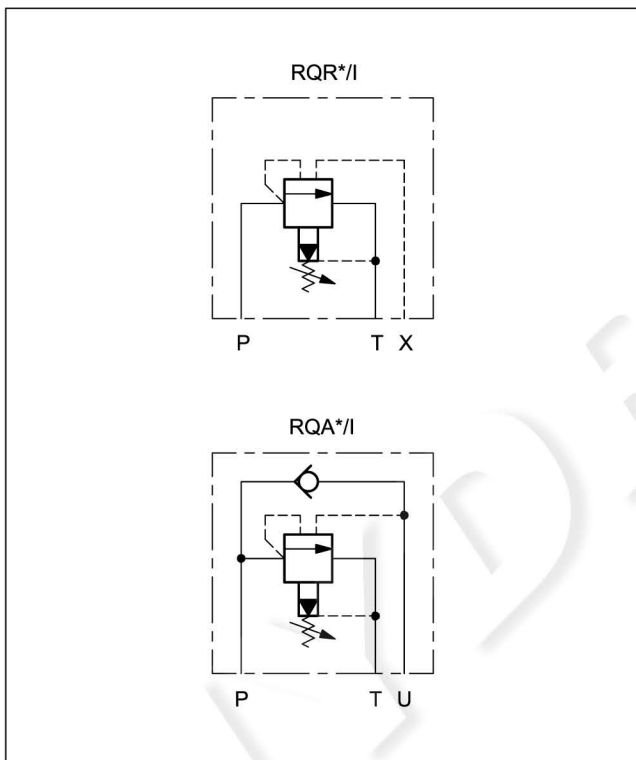

OPERATING PRINCIPLE

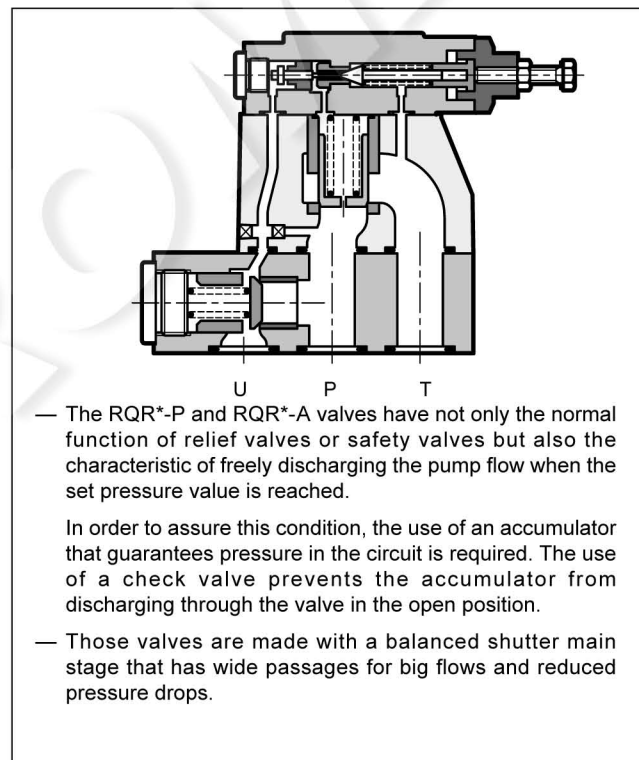

PERFORMANCES

(measured with mineral oil of viscosity 36 cSt at 50°C)

		RQR3-P	RQR5-P	RQR7-P	RQA5-P	RQA7-P
Maximum operating pressure	bar	350				
Maximum flow rate	l/min	200	400	500	400	500
Ambient temperature range	°C	-20 / +60				
Fluid temperature range	°C	-20 / +80				
Fluid viscosity range	cSt	10 ÷ 400				
Fluid contamination degree		According to ISO 4406:1999 class 20/18/15				
Recommended viscosity	cSt	25				
Mass	Kg	3,5	4,3	6,5	10	17

4 - RQR3-P OVERALL AND MOUNTING DIMENSIONS

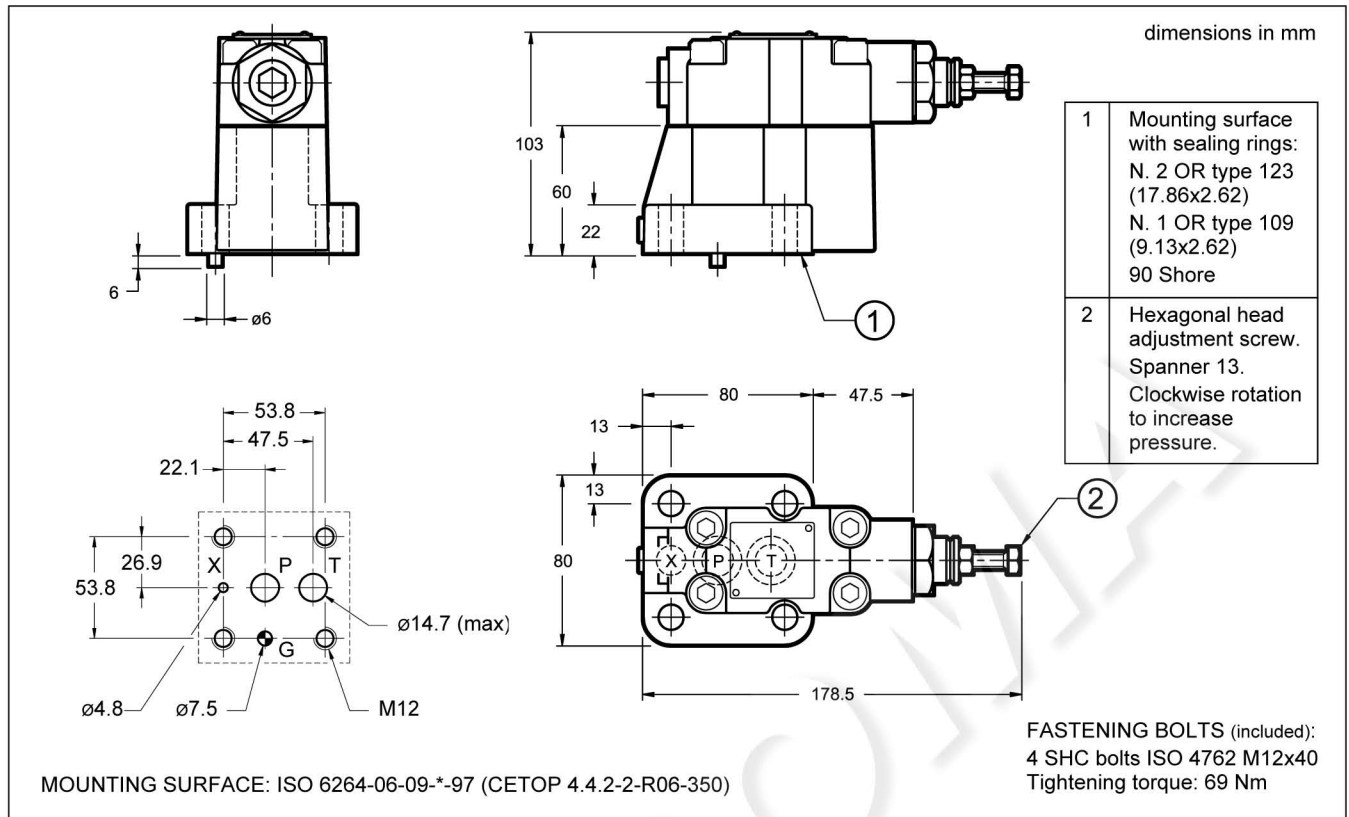

5 - RQR5-P AND RQR7-P OVERALL AND MOUNTING DIMENSIONS

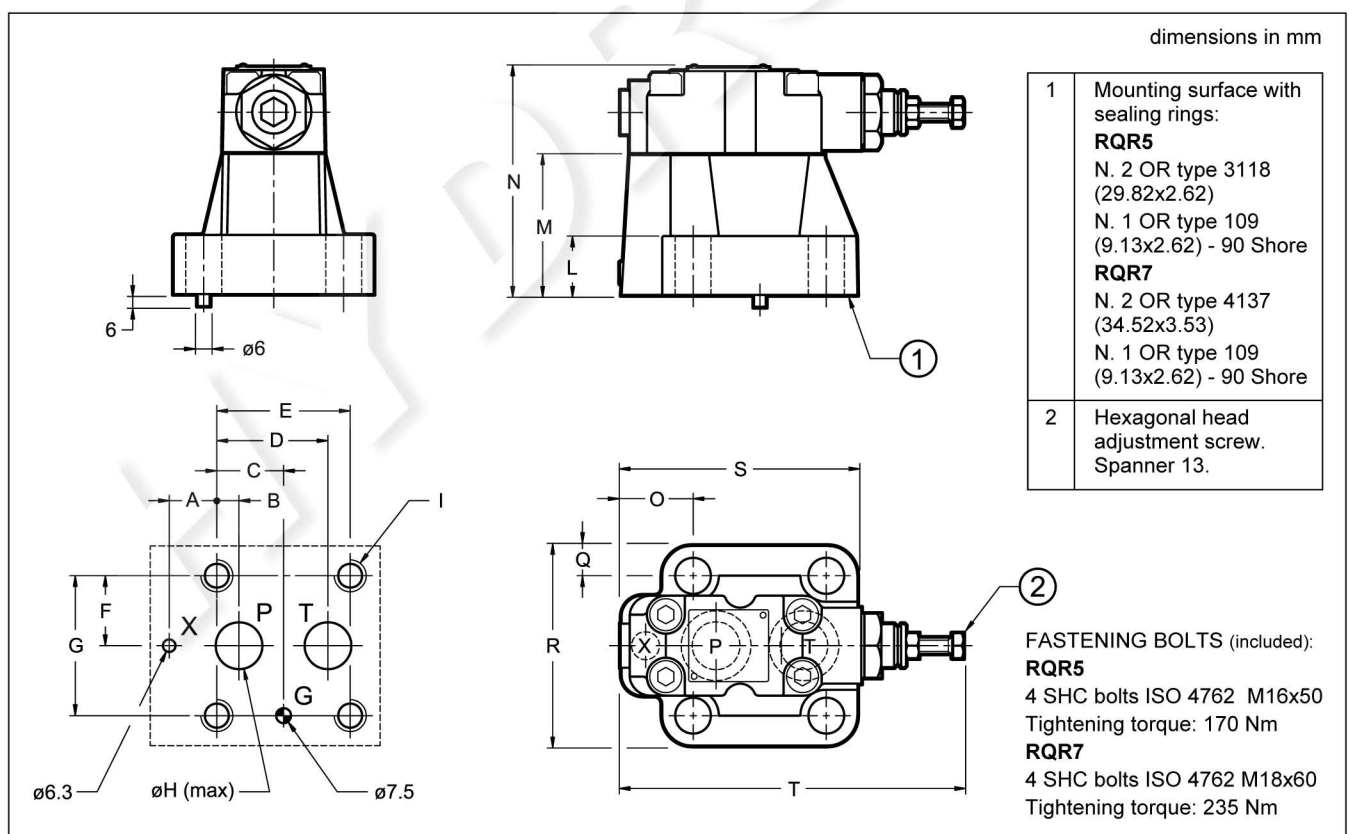

	MOUNTING SURFACE	A	B	C	D	E	F	G	ØH	I	L	M	N	O	Q	R	S	T
RQR5-P	ISO 6264-08-13-*-97 (CETOP 4.4.2-2-R08-350)	23.8	11.1	33.4	55.6	66.7	35	70	23.4	M16	27	70	113	35.8	15	100	118	170
RQR7-P	ISO 6264-10-17-*-97 (CETOP 4.4.2-2-R10-350)	31.8	12.7	44.5	76.2	88.9	41.3	82.6	32	M18	35	80	123	44.1	18.7	120	152	180

6 - RQA5-P AND RQA7P OVERALL AND MOUNTING DIMENSIONS

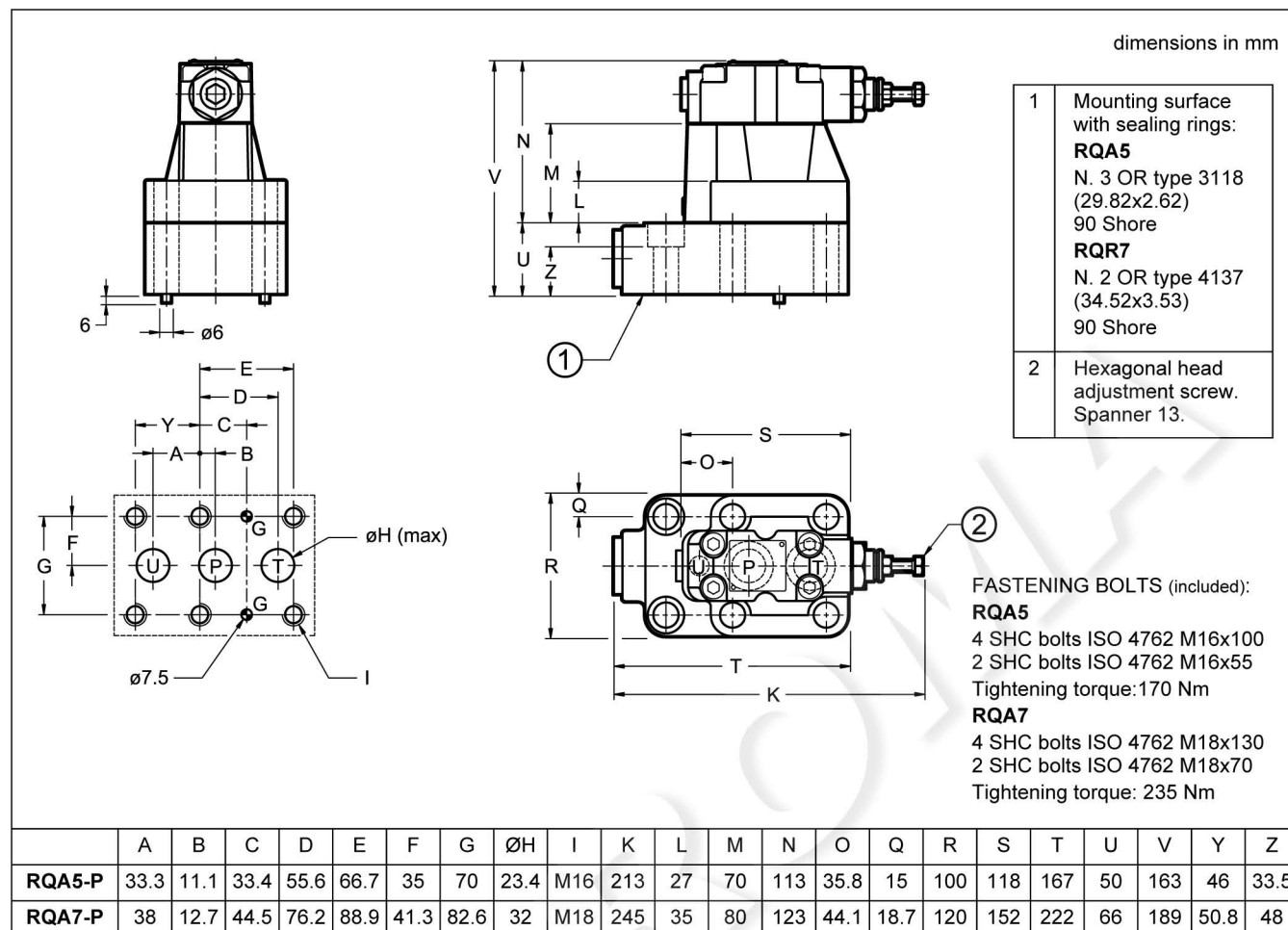

7 - ADJUSTMENT KNOB

The valves can be equipped with a SICBLOC adjustment knob. To operate it, push and rotate at the same time.

To request this option, add **M** (see paragraph 1) in the proper square.

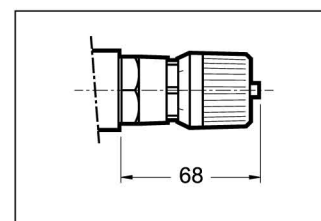

8 - SUBPLATES

(see catalogue 51 000)

	RQR3-P	RQR5-P	RQR7-P	RQA5-P	RQA7-P
Type	PMRQ3-AI4G rear ports	PMRQ5-AI5G rear ports	PMRQ7-AI7G rear ports	PMRQA5-AI5G rear ports	PMRQA7-AI7G rear ports
P, T, U ports dimensions	P: 1/2" BSP T: 3/4" BSP	1" BSP	1" 1/4 BSP	3/4" BSP	1" 1/4 BSP
X port dimension	1/4" BSP	1/4" BSP	1/4" BSP	-	-