

Part number:

HYDROMA

HYDRAULICKÉ SYSTÉMY

**HIDROMA
SYSTEMS**

UKŁADY HYDRAULICZNE

HYDROMA

ГИДРАВЛИЧЕСКИЕ СИСТЕМЫ

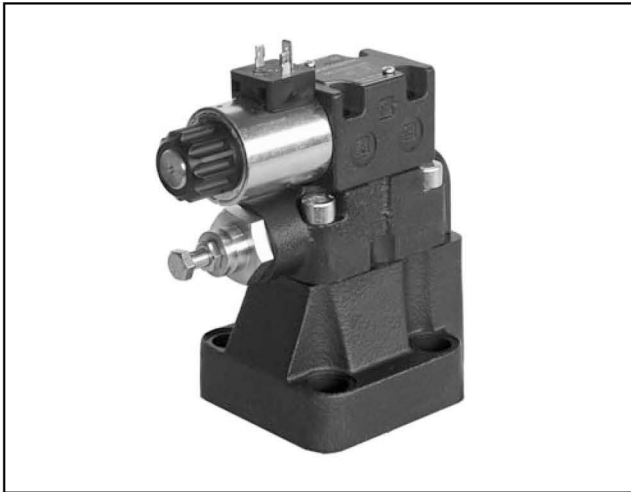

RQM*-P

SOLENOID OPERATED PRESSURE RELIEF VALVES WITH UNLOADING AND PRESSURE SELECTION

SUBPLATE MOUNTING

RQM3-P ISO 6264-06

RQM5-P ISO 6264-08

RQM7-P ISO 6264-10

OPERATING PRINCIPLE

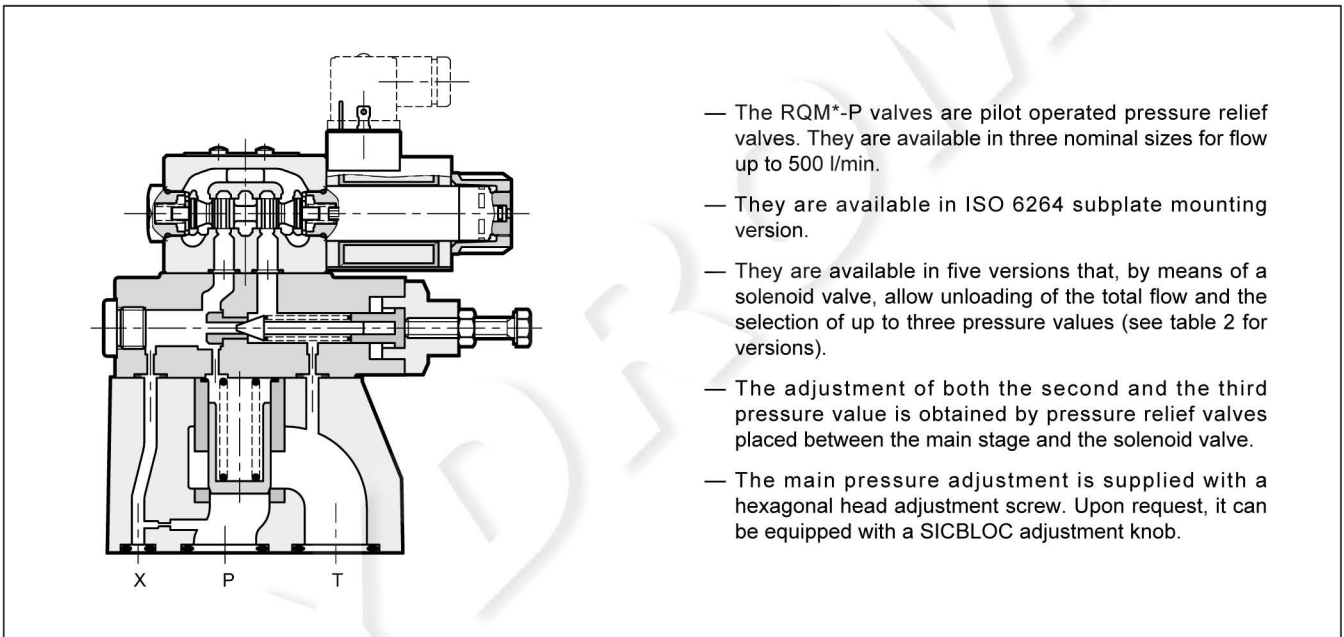

- The RQM*-P valves are pilot operated pressure relief valves. They are available in three nominal sizes for flow up to 500 l/min.
- They are available in ISO 6264 subplate mounting version.
- They are available in five versions that, by means of a solenoid valve, allow unloading of the total flow and the selection of up to three pressure values (see table 2 for versions).
- The adjustment of both the second and the third pressure value is obtained by pressure relief valves placed between the main stage and the solenoid valve.
- The main pressure adjustment is supplied with a hexagonal head adjustment screw. Upon request, it can be equipped with a SICBLOC adjustment knob.

PERFORMANCES

(measured with mineral oil of viscosity 36 cSt at 50°C)

		RQM3-P	RQM5-P	RQM7-P
Maximum operating pressure	bar	350		
Maximum flow rate	l/min	200	400	500
Ambient temperature range	°C	-20 / +50		
Fluid temperature range	°C	-20 / +80		
Fluid viscosity range	cSt	10 ÷ 400		
Fluid contamination degree	According to ISO 4406:1999 class 20/18/15			
Recommended viscosity	cSt	25		

NOTE: for the solenoid valve DS3 characteristics see catalogue 41 150

1 - IDENTIFICATION CODE

R	Q	M	-	P	/	/	/	-	K1	/
----------	----------	----------	----------	----------	---	---	---	----------	-----------	---

Pilot operated pressure relief valve

Solenoid valve for unloading / pressure selection

Size: **3** = ISO 6264-06
5 = ISO 6264-08
7 = ISO 6264-10

Subplate mounting

Pressure adjustment range:
3 = up to 70 bar **6** = up to 350 bar
5 = up to 210 bar

Versions: **A** _____
B see description
C at point 2: versions
D _____
G _____

M = adjustment with SICBLOC knob available only on the main pressure control (Omit for adjustment with hexagonal head screw)

Series No. (the overall and mounting dimensions remain unchanged from 60 to 69) _____
60 = for versions A and B
61 = for versions C, D and G

NOTE: The locking rings of the coils and the relevant O-Rings are supplied together with valves

Manual override: omit for override integrated in the tube (**standard**)
CM = manual override, boot protected

Coil electrical connection: plug for connector type EN 175301-803 (ex DIN 43650) (**standard**)

DC power supply
D12 = 12 V
D24 = 24 V
D48 = 48 V
D110 = 110 V
D220 = 220 V
D00 = valve without coils (see **NOTE**)

AC power supply
A24 = 24 V - 50 Hz
A48 = 48 V - 50 Hz
A110 = 110 V - 50 Hz / 120 V - 60 Hz
A230 = 230 V - 50 Hz / 240 V - 60 Hz
A00 = valve without coils (see **NOTE**)
F110 = 110 V - 60 Hz
F220 = 220 V - 60 Hz

Seals:
N = NBR seals for mineral oil (**standard**)
V = FPM seals for special fluids

2 - VERSIONS

RQM*-P*/A	RQM*-P*/B	RQM*-P*/C	RQM*-P*/D	RQM*-P*/G
<p>1 pressure setting and unloading with de-energized solenoid</p>	<p>1 pressure setting and unloading with energized solenoid</p>	<p>2 pressure settings The highest setting is reached with energized solenoid</p>	<p>2 pressure settings and unloading with de-energized solenoids</p>	<p>3 pressure settings The highest setting is reached with de-energized solenoids</p>

3 - CHARACTERISTIC CURVES (values obtained with viscosity of 36 cSt at 50°C)

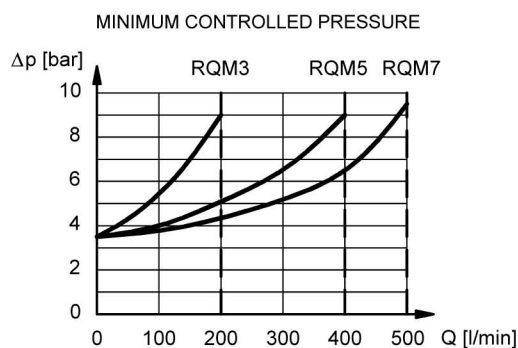
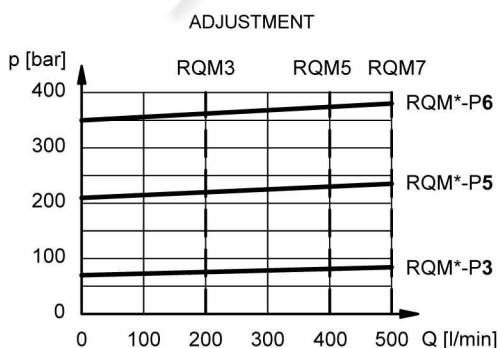

4 - HYDRAULIC FLUIDS

Use mineral oil-based hydraulic fluids HL or HM type, according to ISO 6743-4. For these fluids, use NBR seals (code N). For fluids HFDR type (phosphate esters) use FPM seals (code V). For the use of other kinds of fluid such as HFA, HFB, HFC, please consult our technical department. Using fluids at temperatures higher than 80 °C causes a faster degradation of the fluid and of the seals characteristics.

The fluid must be preserved in its physical and chemical characteristics.

5 - OVERALL AND MOUNTING DIMENSIONS

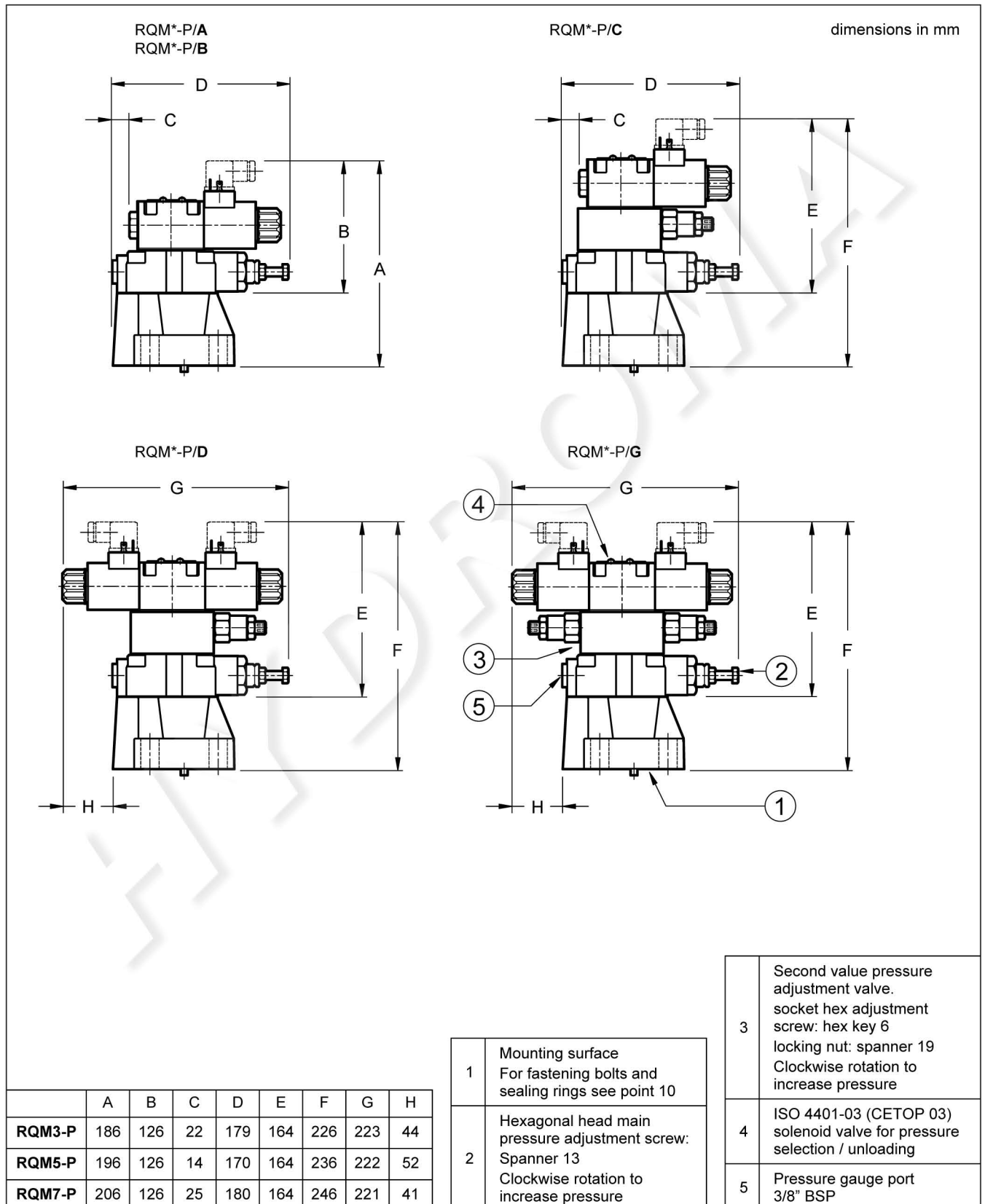

6 - MOUNTING SURFACES

RQM3

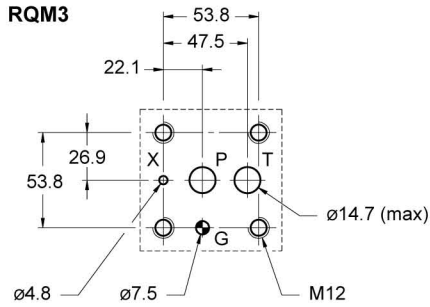

ISO 6264-06-09-*97 (CETOP 4.4.2-2-R06-350)

RQM5

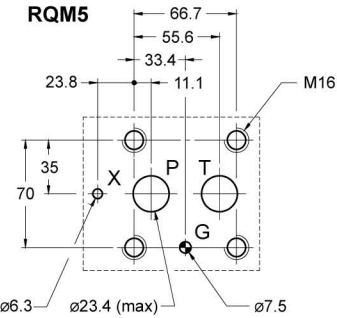

ISO 6264-08-13-*97 (CETOP 4.4.2-2-R08-350)

RQM7

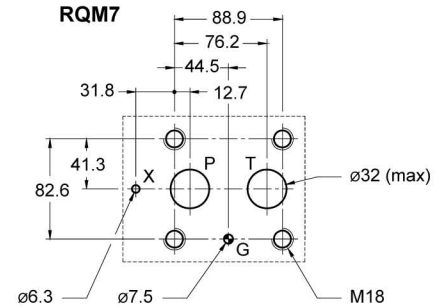

ISO 6264-10-17-*97 (CETOP 4.4.2-2-R10-350)

7 - ADJUSTMENT KNOB

The valves can be equipped with a SICBLOC adjustment knob, only on the main pressure regulation. To operate it, push and rotate at the same time.

To request this option, add: /M (see point 1).

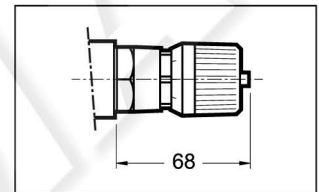

8 - ELECTRIC CONNECTORS

Solenoid operated valves are delivered without connectors. Connectors type EN 175301-803 (ex DIN 43650) for K1 connections can be ordered separately. See catalogue 49 000.

9 - MANUAL OVERRIDE, BOOT PROTECTED: CM

Whenever the solenoid valve installation may involve exposure to atmospheric agents or utilization in tropical climates, the use of the boot protected manual override is recommended.

Add the CM suffix to request this device (see point 1). For overall dimensions see catalogue 41 150.

10 - FASTENING BOLTS AND SEALING RINGS

	RQM3-P	RQM5-P	RQM7-P
Fastening (4 SHC bolts ISO 4762)	M12 x 40	M16 x 50	M18 x 60
Torque	69 Nm	170 Nm	235 Nm
Sealing rings	N. 2 OR type 123 (17.86x2.62) 90 Shore N. 1 OR type 109 (9.13x2.62) 90 Shore	N. 2 OR type 3118 (29.82x2.62) 90 Shore N. 1 OR type 109 (9.13x2.62) 90 Shore	N. 2 OR type 4137 (34.52x3.53) 90 Shore N. 1 OR type 109 (9.13x2.62) 90 Shore

11 - SUBPLATES

(see catalogue 51 000)

	RQM3-P	RQM5-P	RQR7-P
Type	PMRQ3-AI4G rear ports	PMRQ5-AI5G rear ports	PMRQ7-AI7G rear ports
P, T ports dimension	P: 1/2" BSP T: 3/4" BSP	1" BSP	1" 1/4 BSP
X port dimension	1/4" BSP	1/4" BSP	1/4" BSP