

Part number:

**HYDROMA**

HYDRAULICKÉ SYSTÉMY

**HIDROMA  
SYSTEMS**

UKŁADY HYDRAULICZNE

**HYDROMA**

ГИДРАВЛИЧЕСКИЕ СИСТЕМЫ

## HYDRAULIC MOTORS MM



### CONTENTS

Specification data  
Function diagrams  
Dimensions and mounting  
Shaft extensions  
Permissible shaft loads  
Order code

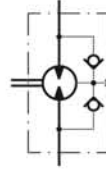

### APPLICATION

- » Conveyors
- » Textile machines
- » Mining machinery
- » Machine tools
- » Ventilators
- » Construction plant equipment and access platforms etc.

### OPTIONS

- » Model - Spool valve, gerotor
- » With or without flange
- » Side and rear ports
- » Series with pressure valve(s)
- » Shafts - straight and splined
- » Metric and BSPP ports
- » Speed sensing;
- » Other special features

**Pressure Settings at Flow**  
Q=2 lpm [.53 GPM], 32 mm<sup>2</sup>/s [150 SUS], 50°C [122°F]

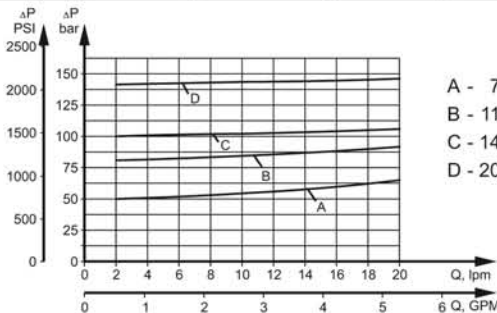

A - 725 PSI [ 50 bar]  
B - 1160 PSI [ 80 bar]  
C - 1450 PSI [100 bar]  
D - 2030 PSI [140 bar]

**MMP Series with Integrated Internal Crossover Relief Valve**  
A → B, Δp=100 or 50 bar [1450 or 725 PSI]

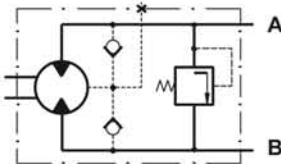

**MMP Series with Integrated Internal Crossover Relief Valve**  
B → A, Δp=100 or 50 bar [1450 or 725 PSI]

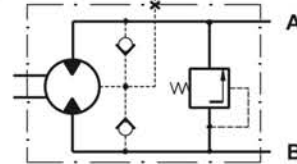

### Pressure Losses

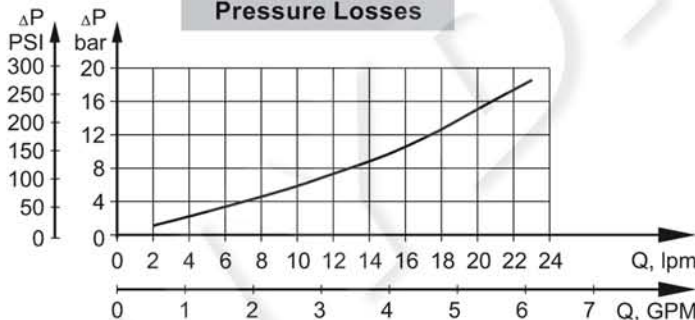

**MMD Series with Integrated Internal Crossover Relief Valves**  
A ↔ B, Δp=100 or 50 bar [1450 or 725 PSI]

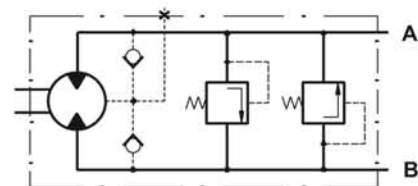

### GENERAL

Max. Displacement,	cm <sup>3</sup> /rev [in <sup>3</sup> /rev]	50 [3.05]
Max. Speed,	[RPM]	2440
Max. Torque,	daNm [lb-in]	cont.: 4,5 [398]    int.: 5,8 [513]
Max. Output,	kW [HP]	3,2 [4.3]
Max. Pressure Drop,	bar [PSI]	cont.: 105 [1500]    int.: 140 [2030]
Max. Oil Flow,	lpm [GPM]	25 [6.6]
Min. Speed,	[RPM]	20
Pressure fluid		Mineral based- HLP(DIN 51524) or HM(ISO 6743/4)
Temperature range,	°C [°F]	-40+140 [-40+284]
Optimal Viscosity range,	mm <sup>2</sup> /s [SUS]	20+75 [98+347]
Filtration		ISO code: 18/16/13    According to ISO 4406-1999

## SPECIFICATION DATA

Type		MM 8	MM 12.5	MM 20	MM 32	MM 40	MM 50
<b>Displacement, cm<sup>3</sup>/rev [in<sup>3</sup>/rev]</b>		8,2 [50]	12,5 [77]	19,9 [1.22]	31,6 [1.93]	39,8 [2.43]	50 [3.08]
<b>Max. Speed, [RPM]</b>	Cont.	1950	1550	1000	630	500	400
	Int.*	2450	1940	1250	800	630	500
<b>Max. Torque daNm [lb-in]</b>	Cont.	1,1 [95]	1,6 [140]	2,5 [220]	4,0 [350]	4,5 [400]	4,6 [410]
	Int.*	1,5 [135]	2,3 [200]	3,5 [310]	5,7 [500]	7,0 [620]	8,8 [780]
	Peak**	2,1 [187]	3,3 [293]	5,1 [453]	6,4 [568]	8,2 [725]	10,0 [885]
<b>Max. Output kW [HP]</b>	Cont.	1,8 [2.4]	2,4 [3.2]	2,4 [3.2]	2,4 [3.2]	2,2 [3.0]	1,8 [2.4]
	Int.*	2,6 [3.5]	3,2 [4.3]	3,2 [4.3]	3,2 [4.3]	3,2 [4.3]	3,2 [4.3]
<b>Max. Pressure Drop bar [PSI]</b>	Cont.	100 [1450]	100 [1450]	100 [1450]	100 [1450]	90 [1310]	70 [1020]
	Int.*	140 [2030]	140 [2030]	140 [2030]	140 [2030]	140 [2030]	140 [2030]
	Peak**	200 [2900]	200 [2900]	200 [2900]	160 [2320]	160 [2320]	160 [2320]
<b>Max. Oil Flow lpm [GPM]</b>	Cont.	16 [4.2]	20 [5.3]	20 [5.3]	20 [5.3]	20 [5.3]	20 [5.3]
	Int.*	20 [5.3]	25 [6.6]	25 [6.6]	25 [6.6]	25 [6.6]	25 [6.6]
<b>Max. Inlet Pressure bar [PSI]</b>	Cont.	140 [2030]	140 [2030]	140 [2030]	140 [2030]	140 [2030]	140 [2030]
	Int.*	175 [2540]	175 [2540]	175 [2540]	175 [2540]	175 [2540]	175 [2540]
	Peak**	225 [3260]	225 [3260]	225 [3260]	225 [3260]	225 [3260]	225 [3260]
<b>Max. Return Pressure without Drain Line or Max. Pressure in Drain Line, bar [PSI]</b>	Cont. 0-100 RPM	140 [2030]	140 [2030]	140 [2030]	140 [2030]	140 [2030]	140 [2030]
	Cont. 100-400 RPM	105 [1500]	105 [1500]	105 [1500]	105 [1500]	105 [1500]	105 [1500]
	Cont. 400-800 RPM	50 [725]	50 [725]	50 [725]	50 [725]	50 [725]	50 [725]
	Cont. >800 RPM	20 [290]	20 [290]	20 [290]	-	-	-
Int.* 0-max. RPM	140 [2030]	140 [2030]	140 [2030]	140 [2030]	140 [2030]	140 [2030]	
<b>Max. Return Pressure with Drain Line bar [PSI]</b>	Cont.	140 [2030]	140 [2030]	140 [2030]	140 [2030]	140 [2030]	140 [2030]
	Int.*	175 [2540]	175 [2540]	175 [2540]	175 [2540]	175 [2540]	175 [2540]
	Peak**	225 [3260]	225 [3260]	225 [3260]	225 [3260]	225 [3260]	225 [3260]
<b>Max. Starting Pressure with Unloaded Shaft, bar [PSI]</b>		4 [60]	4 [60]	4 [60]	4 [60]	4 [60]	4 [60]
<b>Min. Starting Torque daNm [lb-in]</b>	At max. press. drop Cont.	0,7 [60]	1,2 [105]	2,1 [185]	3,4 [300]	3,8 [335]	4,1 [365]
	At max. press. drop Int.*	1,0 [90]	1,7 [150]	2,9 [255]	4,8 [425]	6,2 [550]	7,9 [700]
<b>Min. Speed***, [RPM]</b>		50	40	30	30	25	20
<b>Weight, kg [lb] For "F" flange: + 0,200 [.441]</b>	MM	1,9 [4.2]	2,0 [4.41]	2,1 [4.63]	2,2 [4.85]	2,3 [5.07]	2,5 [5.51]
	MMF(S)	2,0 [4.41]	2,1 [4.63]	2,2 [4.85]	2,3 [5.07]	2,4 [5.29]	2,6 [5.73]
	MMP	2,2 [4.85]	2,3 [5.07]	2,4 [5.29]	2,5 [5.51]	2,6 [5.73]	2,8 [6.17]
	MMD	2,6 [5.73]	2,7 [5.95]	2,8 [6.17]	2,9 [6.39]	3,0 [6.61]	3,2 [7.05]

\* Intermittent operation: the permissible values may occur for max. 10% of every minute.

\*\* Peak load: the permissible values may occur for max. 1% of every minute.

\*\*\* For speeds lower than given, consult factory or your regional manager.

1. Intermittent speed and intermittent pressure must not occur simultaneously.
2. Recommended filtration is per ISO cleanliness code 20/16. A nominal filtration of 25 micron or better.
3. Recommend using a premium quality, anti-wear type mineral based hydraulic oil HLP(DIN51524) or HM ( ISO 6743/4).  
If using synthetic fluids consult the factory for alternative seal materials.
4. Recommended minimum oil viscosity 13 mm<sup>2</sup>/s [70 SUS] at 50°C [122°F].
5. Recommended maximum system operating temperature is 82°C [180°F].
6. To assure optimum motor life fill with fluid prior to loading and run at moderate load and speed for 10-15 minutes.

**FUNCTION DIAGRAMS**

**MM 8**

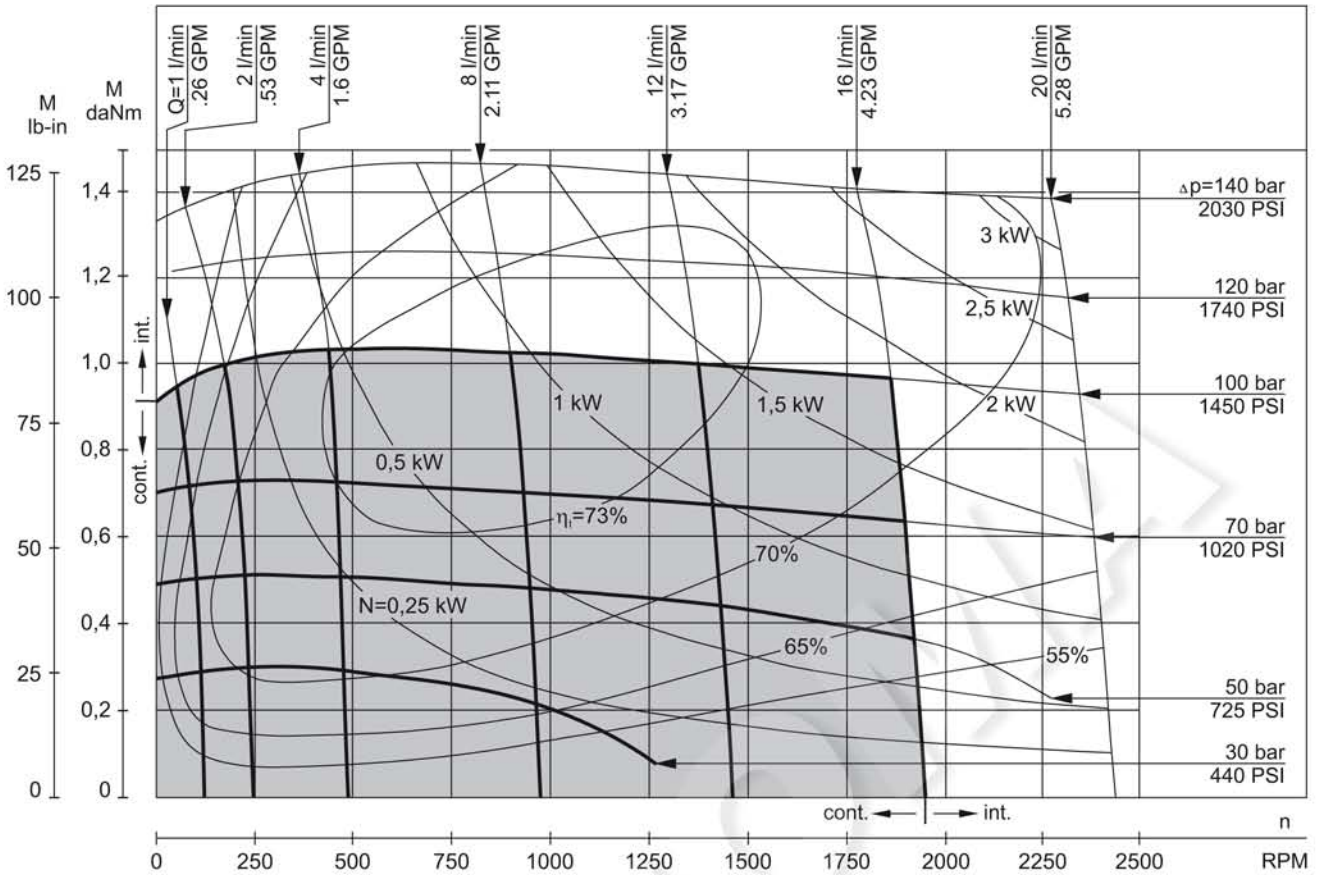

**MM 12,5**

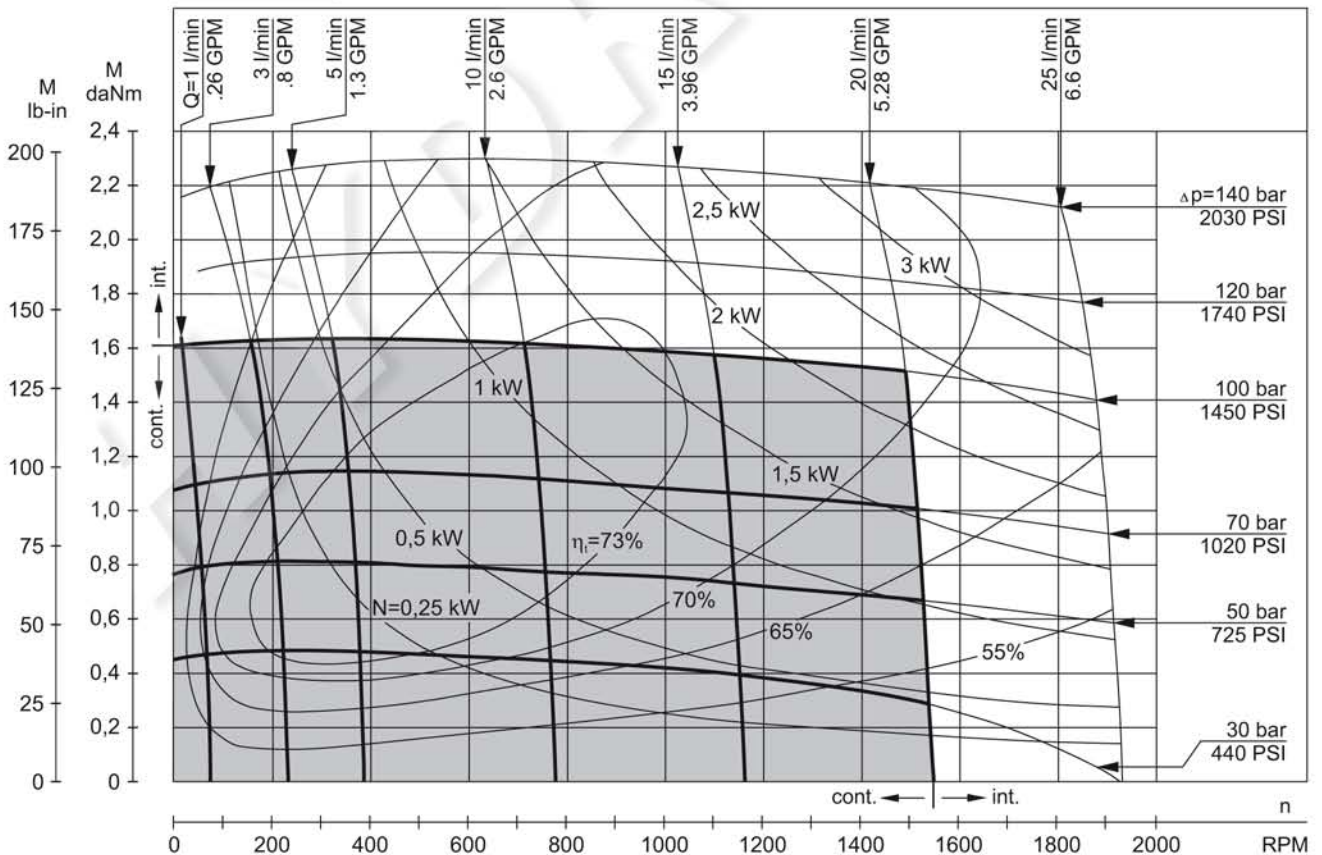

The function diagrams data is for average performance of randomly selected motors at back pressure 5÷10 bar [72.5÷145 PSI] and oil with viscosity of 32 mm<sup>2</sup>/s [150 SUS] at 50°C [122°F].

**FUNCTION DIAGRAMS**

**MM 20**

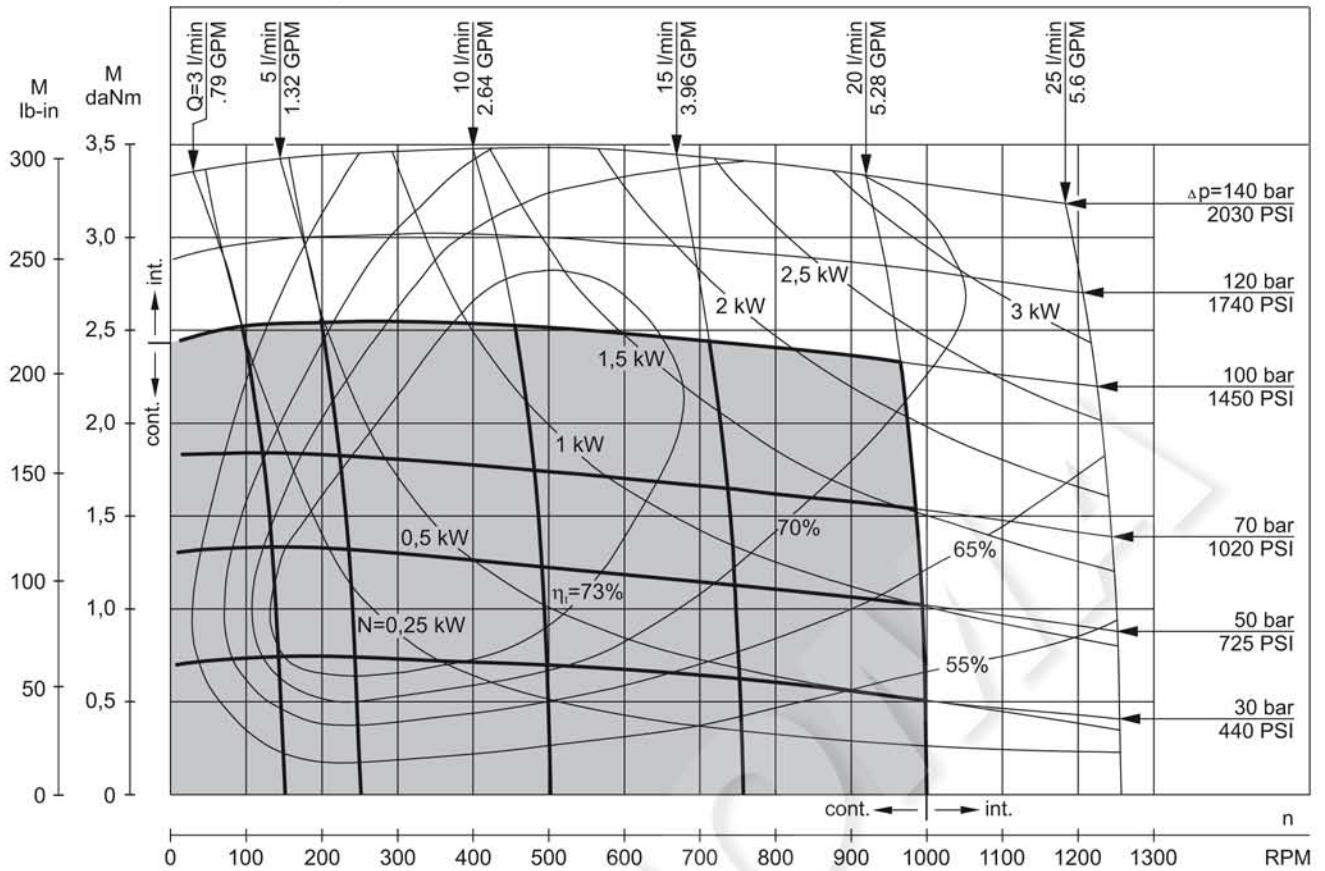

**MM 32**

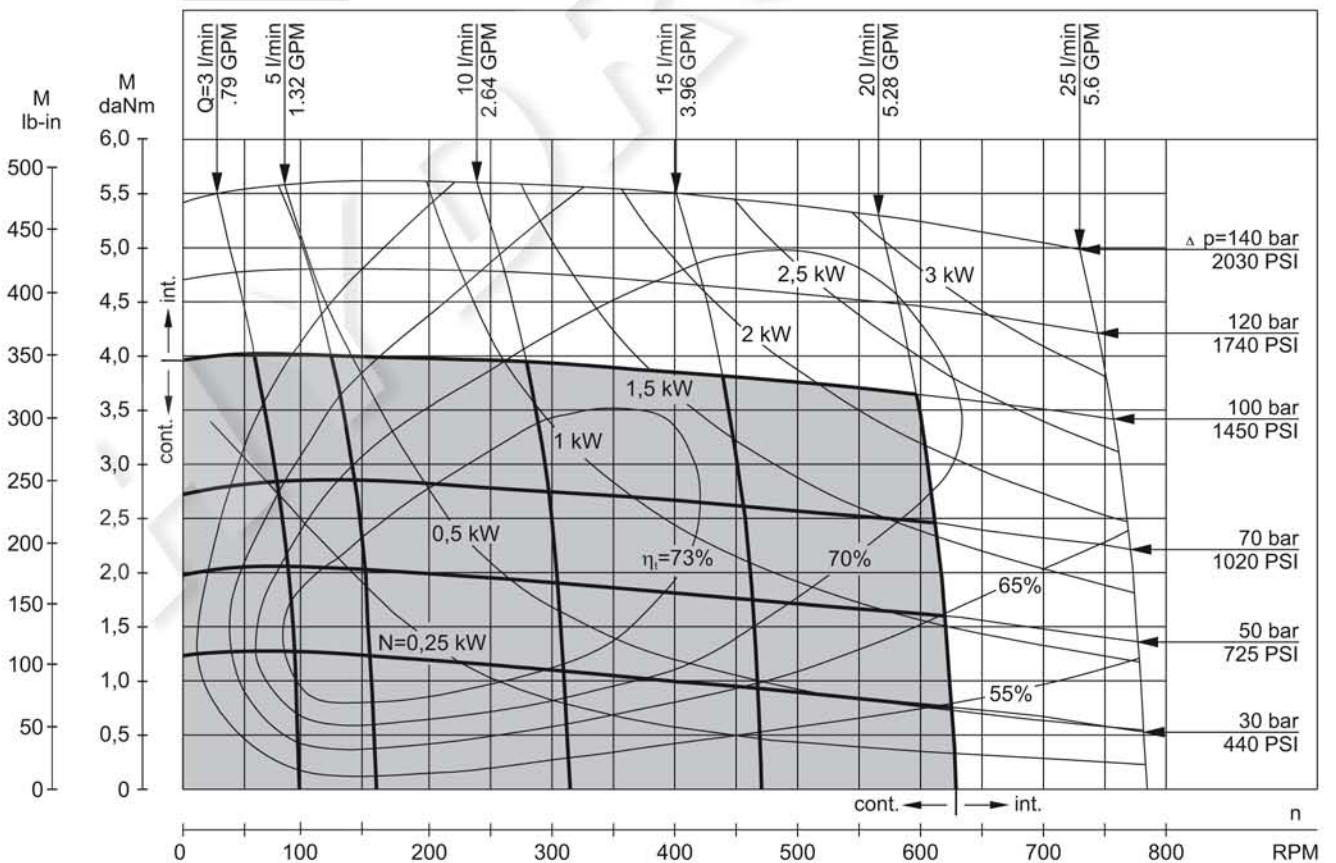

The function diagrams data is for average performance of randomly selected motors at back pressure 5÷10 bar [72.5÷145 PSI] and oil with viscosity of 32 mm<sup>2</sup>/s [150 SUS] at 50°C [122°F].

**FUNCTION DIAGRAMS**

**MM 40**

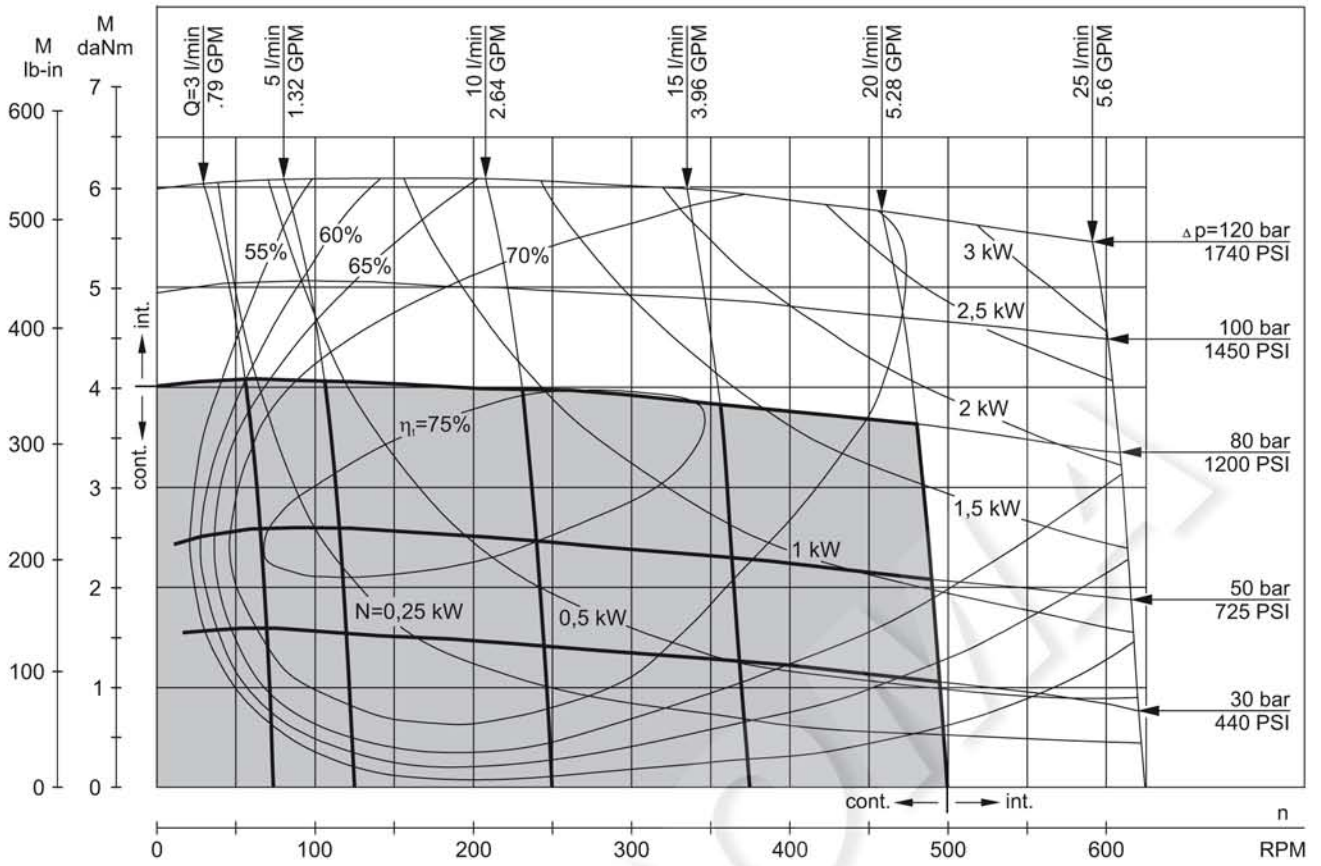

**MM 50**

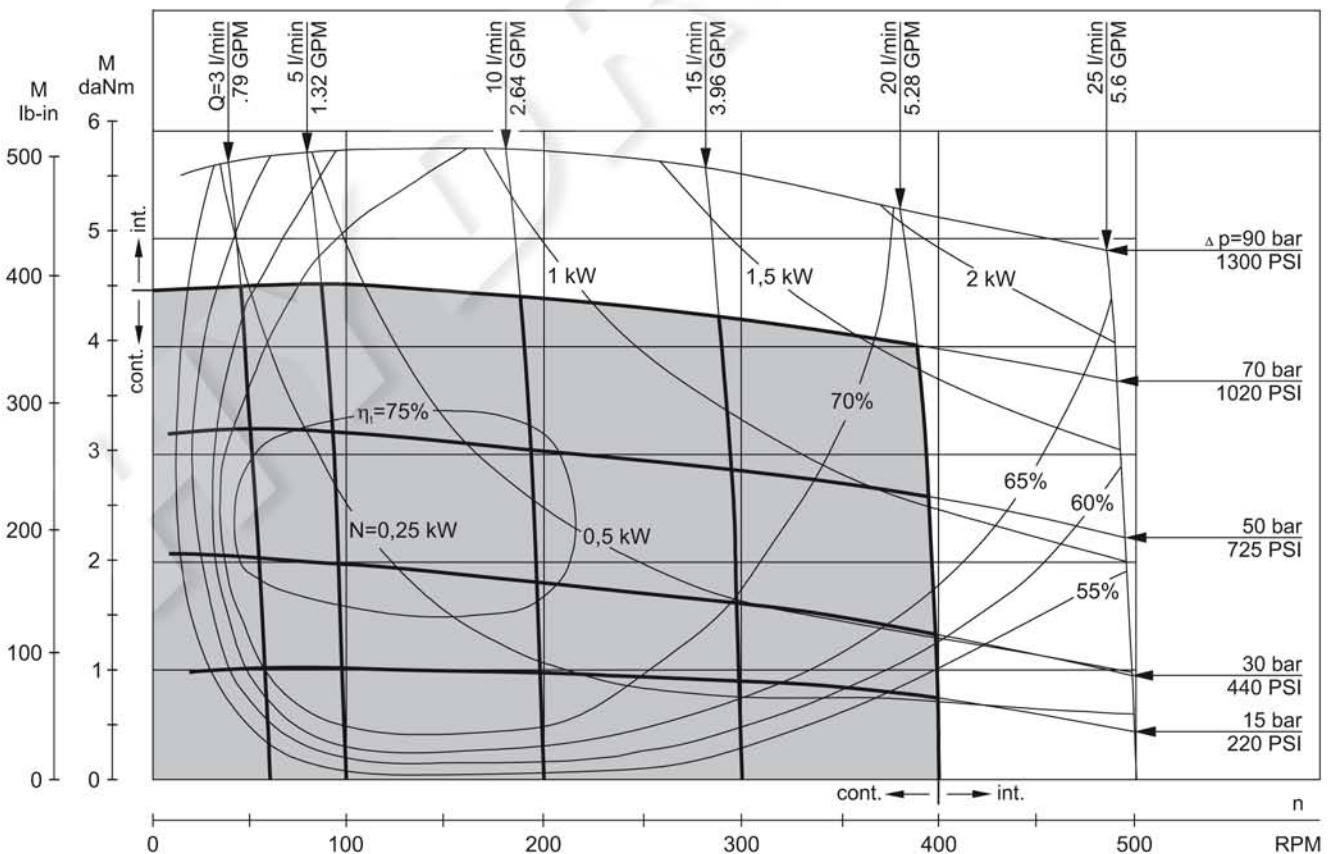

The function diagrams data is for average performance of randomly selected motors at back pressure 5÷10 bar [72.5÷145 PSI] and oil with viscosity of 32 mm<sup>2</sup>/s [150 SUS] at 50°C [122°F].

**DIMENSIONS AND MOUNTING DATA**  
**MM, MMS, MMP, MMD**

Three Bolts Mount  
SH Shaft C Shaft CK Shaft

**F** Oval Mount (2 Holes)

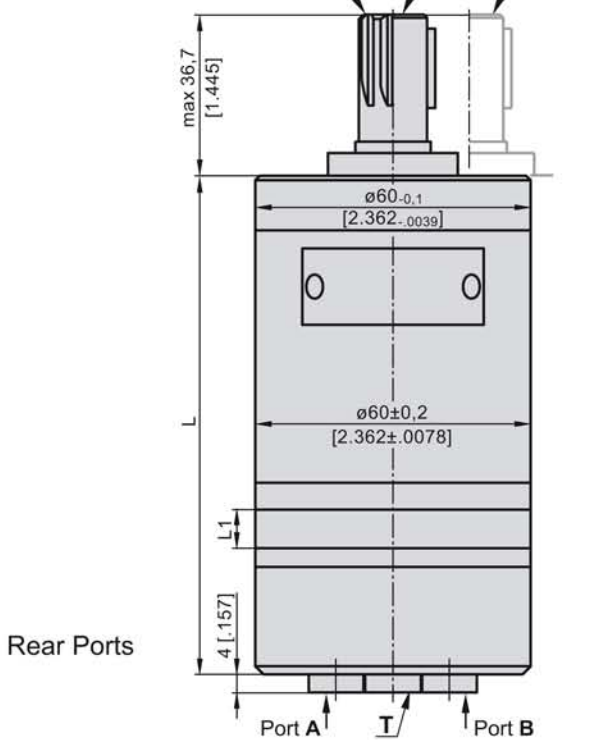

Shaft Dim.  
See Page 11

Flange Dim.  
See Page 10

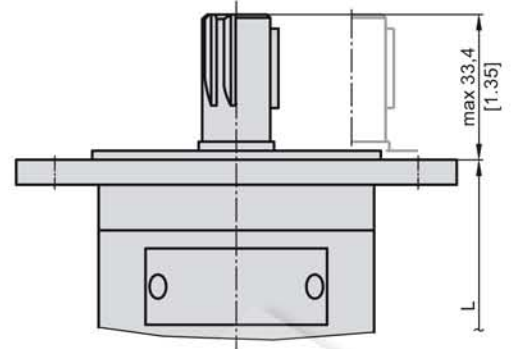

Rear Ports

**Standard Rotation**  
Viewed from Shaft End  
Port A Pressurized - **CW**  
Port B Pressurized - **CCW**

**Reverse Rotation**  
Viewed from Shaft End  
Port A Pressurized - **CCW**  
Port B Pressurized - **CW**

Port Dim.  
See Page 10

**S** Side Ports

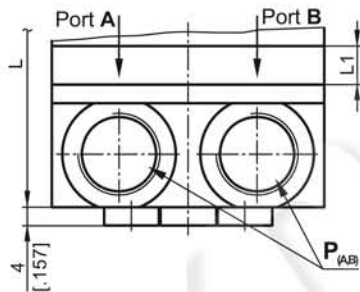

$P_{(A,B)}$ : 2xG3/8 or 2xM18x1,5 - 12 mm [.47 in] depth  
 $T$ : G1/8 or M10x1 - 10 mm [.39 in] depth

**P** Side Ports

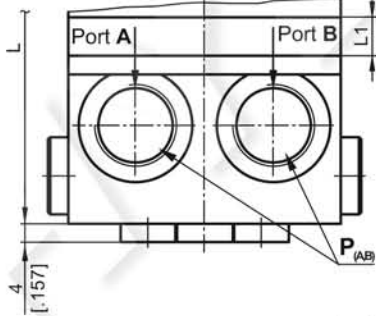

**D** Side Ports

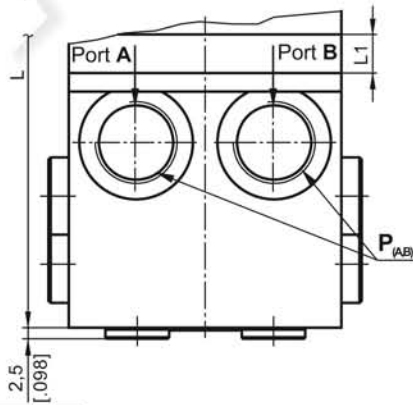

Type	L, mm [in]	Type	L, mm [in]	L <sub>1</sub> , mm [in]
MM 8	105 [4.134]	MMS 8	106,4 [4.189]	3,5 [.138]
MM 12,5	107 [4.213]	MMS 12,5	108,4 [4.268]	5,5 [.217]
MM 20	110 [4.331]	MMS 20	111,4 [4.386]	8,5 [.335]
MM 32	115 [4.528]	MMS 32	116,4 [4.583]	13,5 [.531]
MM 40	118,5 [4.665]	MMS 40	119,9 [4.720]	17 [.669]
MM 50	122,5 [4.823]	MMS 50	123,9 [4.878]	21 [.827]

Type	L, mm [in]	Type	L, mm [in]	L <sub>1</sub> , mm [in]
MMP 8	116 [4.567]	MMD 8	135,1 [5.319]	3,5 [.138]
MMP 12,5	118 [4.646]	MMD 12,5	137,1 [5.398]	5,5 [.217]
MMP 20	121 [4.764]	MMD 20	140,1 [5.516]	8,5 [.335]
MMP 32	126 [4.961]	MMD 32	145,1 [5.713]	13,5 [.531]
MMP 40	129,5 [5.098]	MMD 40	148,6 [5.850]	17 [.669]
MMP 50	133,5 [5.256]	MMD 50	152,6 [6.008]	21 [.827]

For "F" Flange +3,5 mm



**MOUNTING**

**Three Bolts Mount**

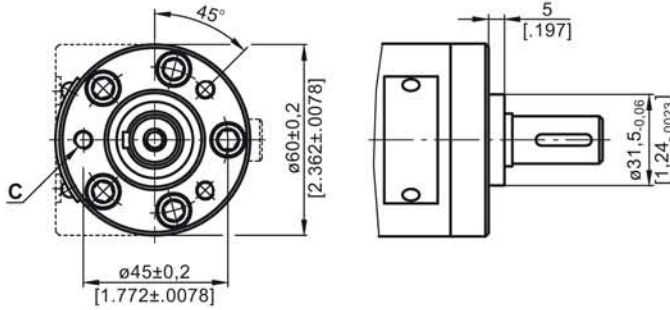

**F Oval Mount (2 Holes)**

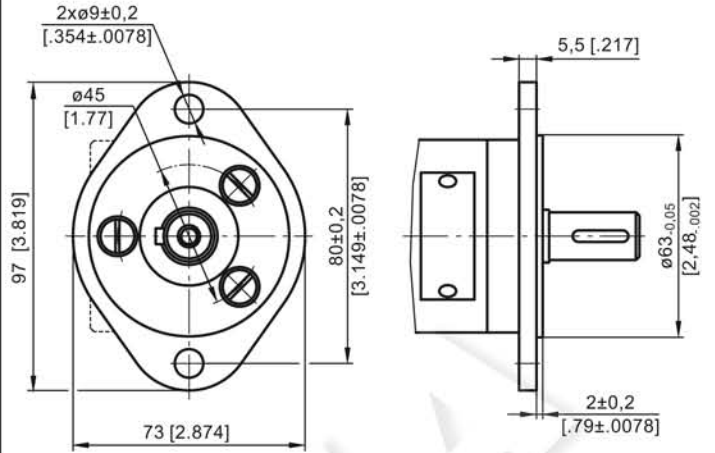

**PORTS**

**Rear Ports**

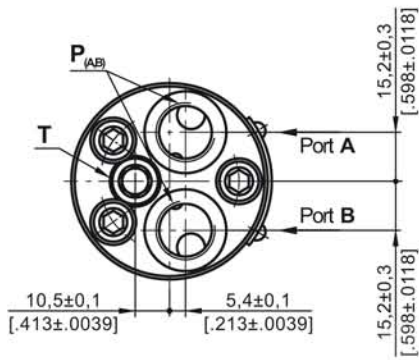

**S Side Ports**

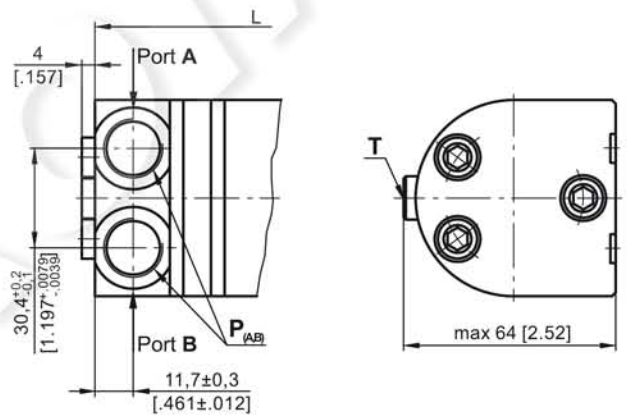

**P Side Ports with Single Crossover Relief Valve**

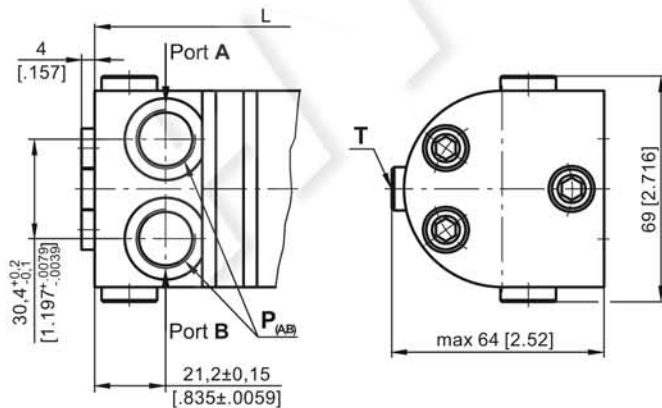

**D Side Ports with Dual Crossover Relief Valve**

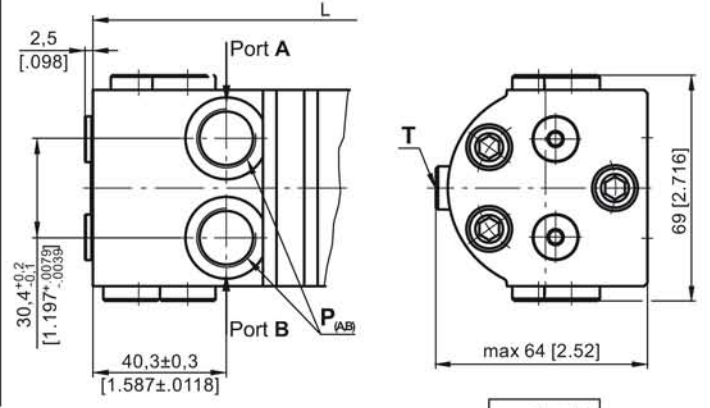

**Standard Rotation**  
Viewed from Shaft End  
Port A Pressurized - **CW**  
Port B Pressurized - **CCW**

**Reverse Rotation**  
Viewed from Shaft End  
Port A Pressurized - **CCW**  
Port B Pressurized - **CW**

**C** : 3xM6 - 12 mm [.47 in] depth  
**P<sub>(A,B)</sub>** : 2xG3/8 or 2xM18x1,5 - 12 mm [.47 in] depth  
**T** : G1/8 or M10x1 - 10 mm [.39 in] depth

**SHAFT EXTENSIONS**

**C** -  $\varnothing 16$  straight, Parallel key 5x5x16 DIN 6885  
Max. Torque 3,9 daNm [345 lb-in]

**CK** -  $\varnothing 14$  straight, Parallel key 5x5x16 DIN 6885  
Max. Torque 3 daNm [265 lb-in]

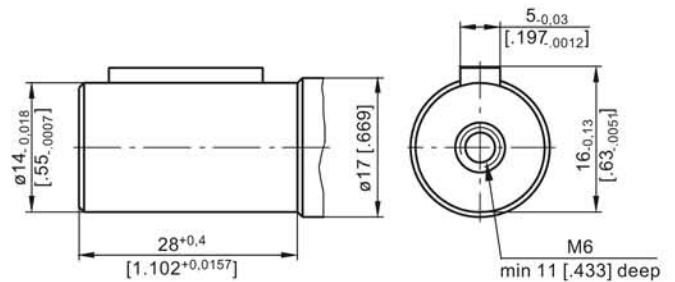
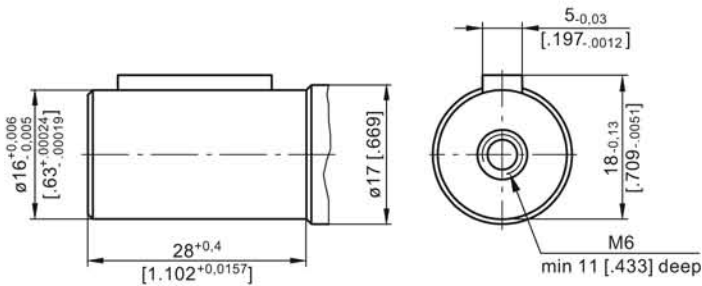

**SH** -  $\varnothing 16,5$  Splined, B17x14 DIN 5482  
Max. Torque 4,4 daNm [390 lb-in]

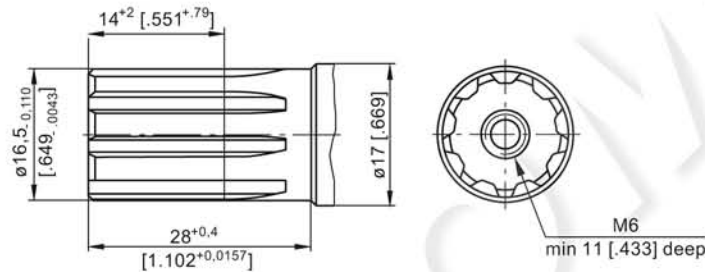

**PERMISSIBLE SHAFT LOAD**

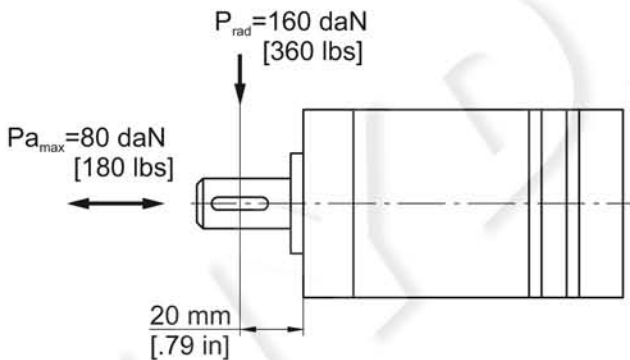

The permissible radial shaft load [Prad] is calculated from the distance [L] between the point of load application and the mounting surface:

$$P_{rad} = \frac{600}{n} \times \frac{13040}{61,5+L}, \text{ [daN]}$$

[L in mm; L ≤ 80 mm]

$$P_{rad} = \frac{600}{n} \times \frac{1155}{2.42 + L}, \text{ [lbs]}$$

[L in inch; L ≤ 3.15 in]

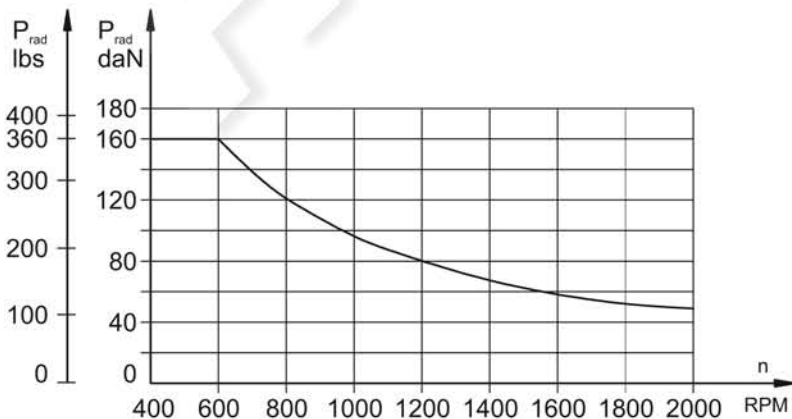

The drawing shows the permissible radial load when L=20 mm [0.79 in].

If the calculated shaft load exceeds the permissible, a flexible coupling must be used.



## ORDER CODE

	1	2	3	4	5	6	7	8	9	10
<b>MM</b>										

**Pos.1 - Adjustment Option**

- omit - without valve
- P** - Side ports with single crossover relief valve
- D** - Side ports with dual crossover relief valve

**Pos.2 - Mounting Flange**

- omit - Three bolts mount valve
- F** - Oval mount, two holes

**Pos.3 - Port type (not valid for P and D version)**

- omit - Rear ports
- S** - Side ports

**Pos.4 - Displacement code**

- 8** - 8,2 cm<sup>3</sup>/rev [ .5 in<sup>3</sup>/rev]
- 12.5** - 12,9 cm<sup>3</sup>/rev [ .79 in<sup>3</sup>/rev]
- 20** - 20,0 cm<sup>3</sup>/rev [1.22 in<sup>3</sup>/rev]
- 32** - 31,8 cm<sup>3</sup>/rev [1.93 in<sup>3</sup>/rev]
- 40** - 40,0 cm<sup>3</sup>/rev [2.44 in<sup>3</sup>/rev]
- 50** - 50,0 cm<sup>3</sup>/rev [3.05 in<sup>3</sup>/rev]

**Pos. 5 - Shaft Extensions\***

- C** - ø16 straight, Parallel key A5x5x16 DIN6885
- VC** - ø16 straight, Parallel key A5x5x16 DIN6885 with corrosion resistant bushing
- CK** - ø14 straight, Parallel key 5x5x16 DIN6885
- SH** - ø16,5 splined, B17x14 DIN 5482

**Pos. 6 - Ports**

- omit - BSPP (ISO 228)
- M** - Metric (ISO 262)

**Pos. 7 - Line to control\*\***

- /L** - B → A (left running)
- /R** - A → B (right running)

**Pos. 8 - Valve Rated Pressure\*\*\***

- /50** - Δp= 50 bar [ 725 PSI]
- /80** - Δp= 80 bar [1160 PSI]
- /100** - Δp=100 bar [1450 PSI]
- /140** - Δp=140 bar [2030 PSI]

**Pos. 9 - Special Features**
**Pos.10 - Design Series**

- omit - Factory specified

**NOTES:** \* The permissible output torque for shafts must not be exceeded!

\*\* For P option useful only.

\*\*\* For P and D option useful only.

**⚠** **MMP** and **MMD** are available with new crossover relief valves with improved characteristics. The valves are set in a wide pressure range: from 50 bar [725 PSI] to 140 bar [2030 PSI]. For more information about MMP and MMD please contact with "M+S Hydraulic".

The Valve pressure setting must be at flow rate of 2 lpm [.53 GPM].

The hydraulic motors are mangan - phosphatized as standard.

### F - FLANGE (2 Holes)

Order No for Flange:48443 014 00

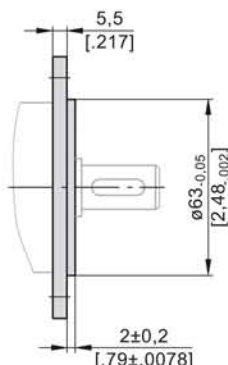
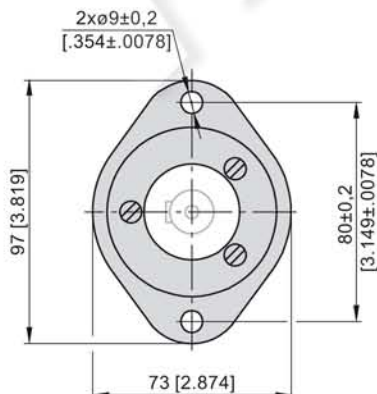

**F** Flange is mounted to the motor with 3 screws - M6x14. Tightening Torque: 5-6 Nm [44-53 lb-in].