

Part number:

**085-10005****HYDROMA**

HYDRAULICKÉ SYSTÉMY

**HIDROMA  
SYSTEMS**

UKŁADY HYDRAULICZNE

**HYDROMA**

ГИДРАВЛИЧЕСКИЕ СИСТЕМЫ

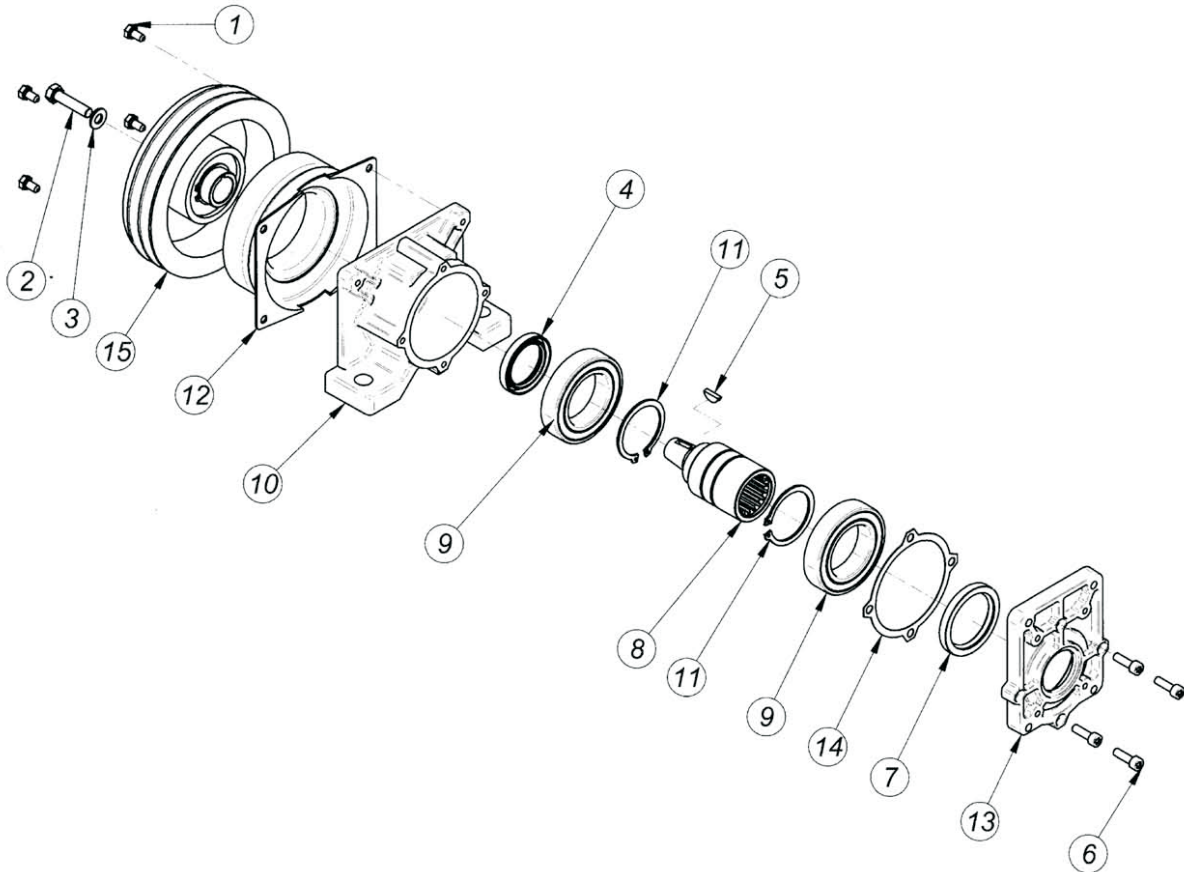

Pos.	CODICE	DENOMINAZIONE	DENOMINATION	DESCRIPTION	BEZEICHNUNG	Q.TA'
1	611428	Vite EN 24017 M6x12	Vis EN24017 M6x12	Socket EN 24017 M6x12	Befestigungsschraube EN 24017 M6x12	4
2	610516	Vite EN 24017 M8x35	Vis EN 24017 M8x35	Socket EN 24017 M8x35	Befestigungsschraube EN 24017 M8x35	1
3	RSPAL8	Rosetta per M8	Rondelle D.8	Washer d.8	Rosette durchm 8	1
4	303550	Anello di tenuta 35x50x7	Bague d'etancheite 35x50x7	Sealing ring 35x50x7	Dichtring 35x50x7	1
5	700465	Linguetta UNI 6606 4x6.5	Languette UNI 6606 4x6.5	Woodruff key UNI 6606 4x6.5	Halbrundkeil UNI 6606 4x6.5	1
6	610620	Vite T.C.E.I M6x20	Vis T.C.H.C. M6x20	Socket capscrew M6x20	Befestigungsschraube UNI 5931 M6x20	4
7	304560	Anello di tenuta 45x60x7	Bague d'etancheite 45x60x7	Sealing ring 45x60x7	Dichtring 45x60x7	1
8	A30901	Albero	Arbre	Shaft	Welle	1
9	506009/2Z	Cuscinetto 6009 2rs	Palier SKF 6009 2RS	Bearing SKF 6009 2RS	Kugellager SKF 6009-2RS	2
10	30009.1	Scatola	Carcasse	Housing	Gehäuse	1
11	904500	Anello elastico d.45	Circlip d.45	Snap ring d.45	Seegerring d.45	2
12	401210/153 402410/153	Bobina	Bobine	Coil	Zundspüle	1
13	30900.1	Flangia per pompe Gr 1 - 2	Flasque puor pompes Gr 1 - 2	Flange for pumps Gr 1 - 2	Flansch fur pompe Gr 1- 2	1
14	30009.1.1	Guarnizione	Joint	Gasket	Dichtung	1
15	4010/153P	Elettrofrizione	Electro-embayage	Electric clutch	Elektroschaltkpllung	1

SERIE: 30901 12 Volt  
 SERIE: 30903 24 Volt

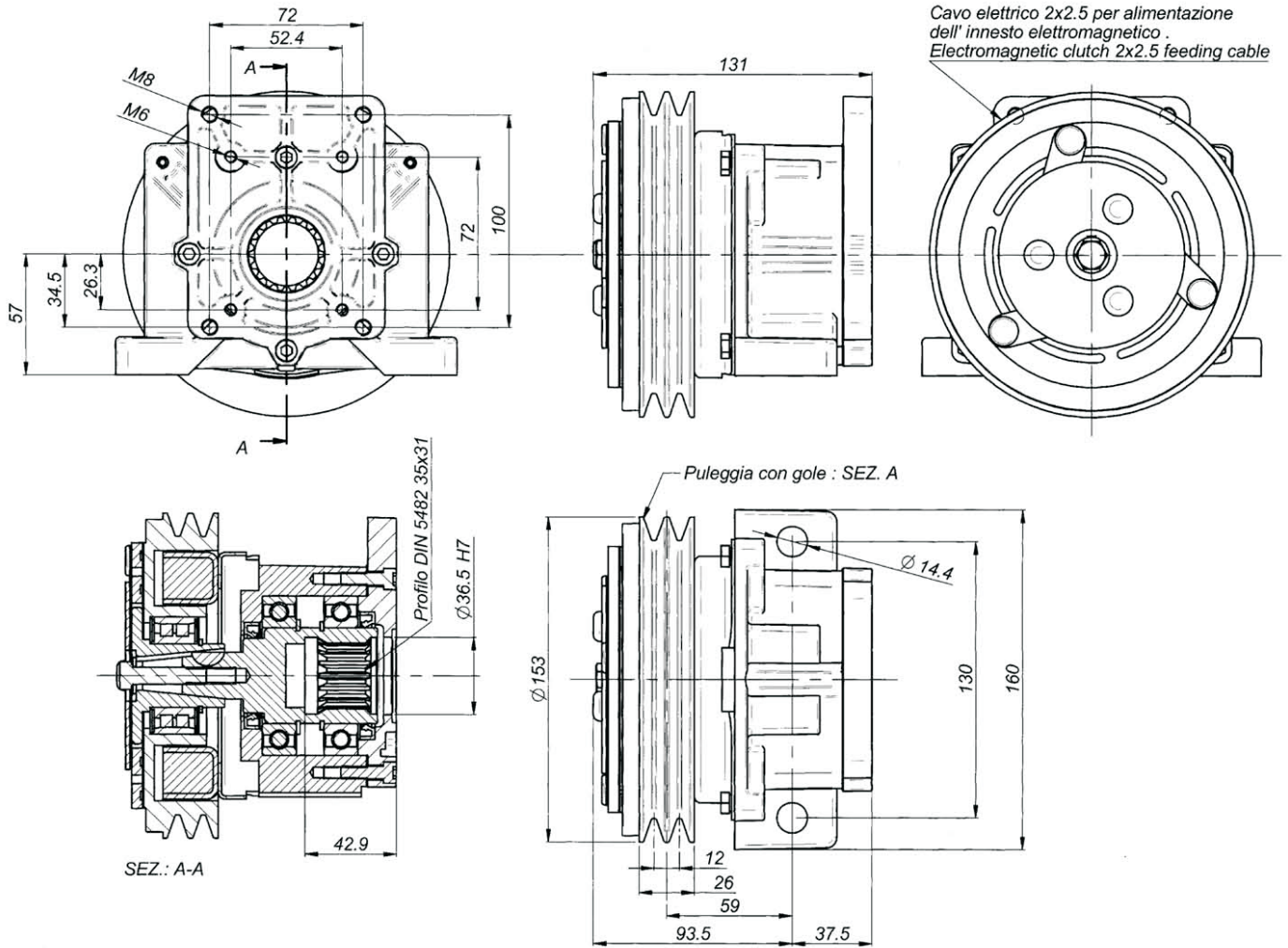

Nominal torque	7,8 daNm		Connection time		25 m/sec	
Static torque	12,5 daNm		Disconnection time		40 m/sec	
Dynamic torque	8,5 daNm	at 500 rpm	Minimun time between two connection		20 sec	
	7,0 daNm	at 1000 rpm				
	4,2 daNm	at 1500 rpm				
	3,5 daNm	at 2000 rpm	Max speed	5000 rpm		
	2,7 daNm	at 2500 rpm	Weight	5,5 Kg		
2,5 daNm	at 3000 rpm					
Electric absorption	Resistance (Ω)		Current (A)		Power (W)	
	20° C	120° C	20° C	120° C	20° C	120° C
12 V DC	4,00	5,60	3,33	2,00	40,00	24,00
24 V DC	20,00	28,00	1,26	0,77	30,30	18,18
All technical data are at 20°C / at 120 °C the performance are less 20% All electromagneteic clutches are reversible.						

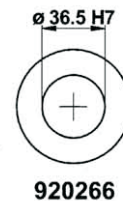
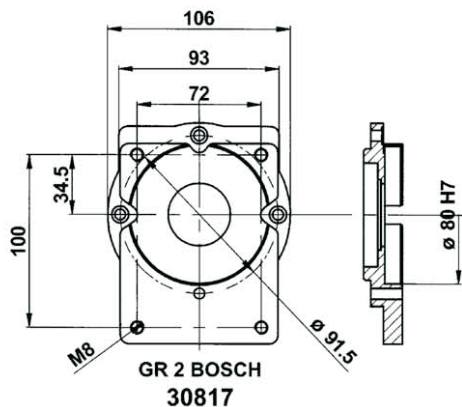
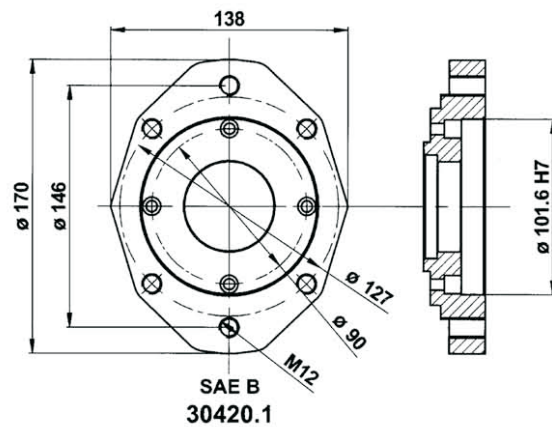
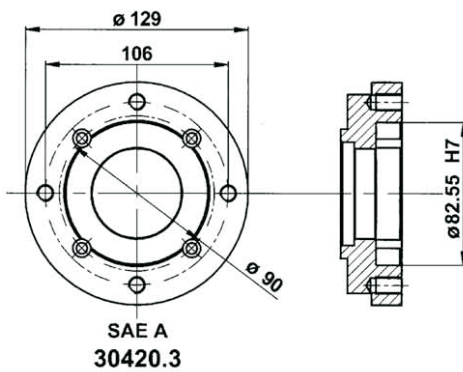
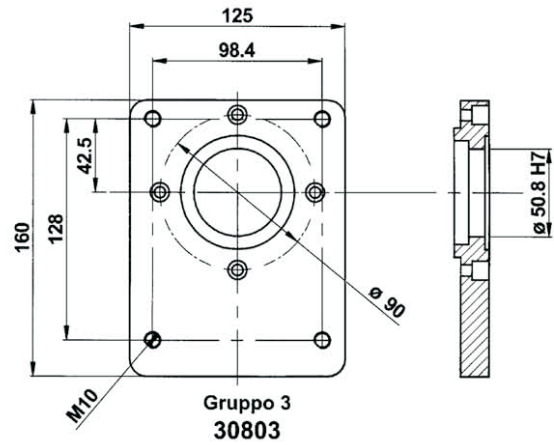
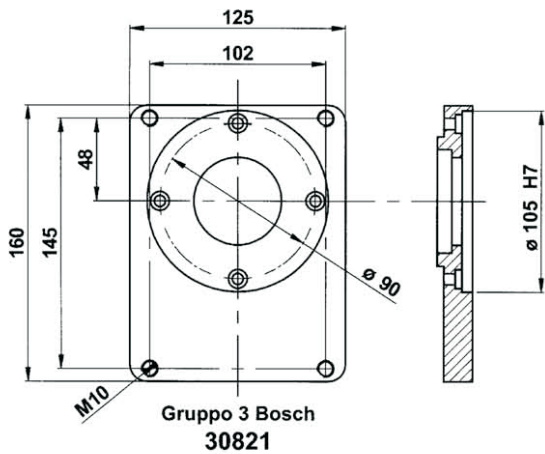

CODICE, CODE, CODE No., CODENUMMER					
Electric absorption	FLANGIA: TIPO, BRIDE: TYPE, FLANGE: TYPE, FLANSCHTYPE				
	Gr.2 BOSCH	Gr.3	Gr. 3 BOSCH	SAE A	SAE B
12 Volt	30917	30909	30925	30901/SA	30901/SB
24 Volt	30919	30911	30927	30903/SA	30903/SB