

Part number:

HYDROMA

HYDRAULICKÉ SYSTÉMY

**HIDROMA
SYSTEMS**

UKŁADY HYDRAULICZNE

HYDROMA

ГИДРАВЛИЧЕСКИЕ СИСТЕМЫ

MDF



Pressure Filters

MODULAR INLINE FILTER

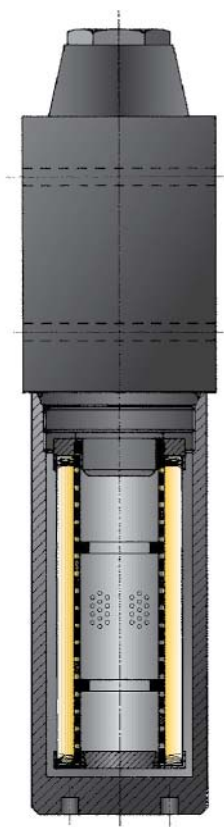
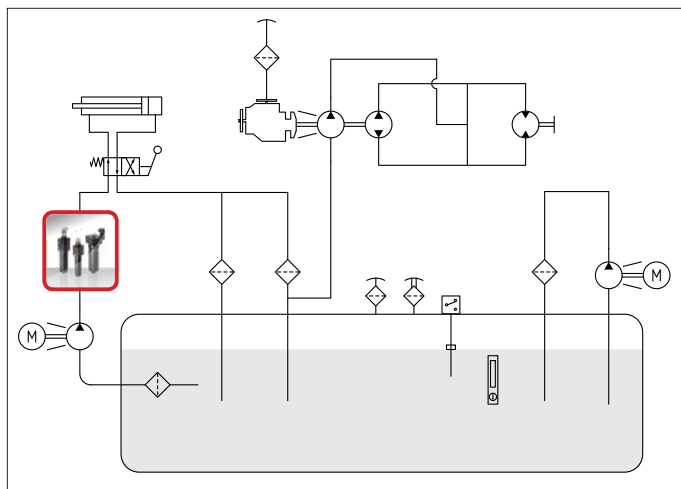

MDF

31,5 MPa (315 bar)

Port sizes: Cetop 03-05-07

Flow rates: 7 ÷ 130 l/min

TECHNICAL DATA

Max. working pressure: 31,5 MPa (315 bar)

Max. test pressure: 40 MPa (400 bar)

Bursting pressure: 94,5 MPa (945 bar)

Fatigue test: 0 ÷ 28 MPa (280 bar) / 1.000.000 cycles

Filter element collapse pressure: Δp 21 MPa (210 bar)

Working temperature: -25 ÷ +110°C

MATERIALS

Head: cast iron

Bowl: forged steel

Seals: standard NBR

on request FKM

COMPATIBILITY (ISO 2943:1999)

Full with fluids: HH-HL-HM-HV-HTG

(according to ISO 6743/4).

For fluids different than the above mentioned, please contact our Sales Department.

All tests performed according to the following standards:

ISO 2941: Element collapse resistance test

ISO 2942: Production integrity test

ISO 2943: Fluids compatibility

ISO 3723: End load test method

ISO 3724: Flow fatigue resistance method

ISO 3968: Pressure drop versus flow rate

ISO 16889: Multipass test.

For further information contact our Technical Dept.

MDF	Type	003	005	007	Type	CCH
		003	152	302		
	Filter media				Filter media	
	2T = 5 μ m ^(c)	2T	2T	2T	2T = 5 μ m ^(c)	
	2C = 7 μ m ^(c) Inorganic fiber	2C	2C	2C	2C = 7 μ m ^(c) Inorganic fiber	
	2D = 12 μ m ^(c) $\beta > 1000 - \Delta p = 21$ MPa (210 bar)	2D	2D	2D	2D = 12 μ m ^(c) $\beta > 1000 - \Delta p = 21$ MPa (210 bar)	
	2V = 21 μ m ^(c)	2V	2V	2V	2V = 21 μ m ^(c)	
	RD = 10 μ Steel wire mesh	-	RD	RD	RD = 10 μ Steel wire mesh	
	MV = 25 μ	-	MV	MV	MV = 25 μ	
	Seals				Seals	
	1 = NBR Nitrile	1	1	1	1 = NBR Nitrile	
	2 = FKM Fluoroelastomer	2	2	2	2 = FKM Fluoroelastomer	
0	Bypass type					
	0 = Whitout	0	0	0		
	Ports					
	C = CETOP	C	C	C		
	Y = Bowl on side B	Y	-	-		
	Port size					
	3 = CETOP 3	3	-	-		
	5 = CETOP 5	-	5	-		
	7 = CETOP 7	-	-	7		
	Indicators					
	03 = Port, plugged	03	03	03		
	5F = Visual differential 800 kPa (8 bar)	5F	5F	5F		
	6F = Electrical differential 800 kPa (8 bar)	6F	6F	6F		
	7F = 6F with LED	7F	7F	7F		
	T3 = Electrical 800 kPa (8 bar) with thermostat 30°C	T3	T3	T3		
					Indicator 73 on request only	
When the filter is ordered with FKM seals, the first digit of the indicator code is a letter (please see page 188-189).						
XX	Accessories					
	XX = Not available	XX	XX	XX		

NBR	FKM	Differential VISUAL indicator
5F	AF	Setting 800 kPa (8 bar)

Recommended tightening torque 90 Nm

NBR	FKM	Differential ELECTRICAL indicator
6F	CF	Setting 800 kPa (8 bar)

SPDT differential switch. C.C. 14 - 30 V: > max resistive or inductive load 4 - 3 A respectively
C.A. 125-250 V: > max resistive or inductive load 1 A - Protection IP65 - Connector DIN 43650

Recommended tightening torque 90 Nm

NBR	FKM	Differential ELECTRICAL indicator with LED (24V) for visual indication
7F	EF	Setting 800 kPa (8 bar)

SPDT differential switch. C.C. 14 - 30 V: > max resistive or inductive load 4 - 3 A respectively
C.A. 125-250 V: > max resistive or inductive load 1 A - Protection IP65 - Connector DIN 43650

Recommended tightening torque 90 Nm

NBR	FKM	Differential ELECTRICAL indicator with THERMOSTAT 30°C
T3	DF	Setting 800 kPa (8 bar)

SPDT differential switch. C.C. 14 - 30 V: > max resistive or inductive load 4 - 3 A respectively
C.A. 125-250 V: > max resistive or inductive load 1 A - Protection IP65 - Connector DIN 43650

Recommended tightening torque 90 Nm

NBR	FKM	Differential VISUAL ELECTRICAL indicator
73	E3	Setting 800 kPa (8 bar)

SPDT differential switch. C.C. 14 - 30 V: > max resistive or inductive load 4 - 3 A respectively
C.A. 125-250 V: > max resistive or inductive load 1 A - Protection IP65 - Connector DIN 43650

Recommended tightening torque 90 Nm

FLOW RATES

(l/min)

Type	Filter Media	Δp			Type	Filter Media	Δp			Type	Filter Media	Δp		
		100 kPa (1 bar)	150 kPa (1,5 bar)	200 kPa (2 bar)			100 kPa (1 bar)	150 kPa (1,5 bar)	200 kPa (2 bar)			100 kPa (1 bar)	150 kPa (1,5 bar)	200 kPa (2 bar)
MDF 003	2T	7,4	9,4	11	MDF 005	2T	24	30	36	MDF 007	2T	60	75	83
	2C	8	10	11,5		2C	25	31	37		2C	66	83	90
	2D	9	11,5	13,5		2D	26	33	39		2D	80	95	112
	2V	9,6	12,2	14,5		2V	27	34	40,5		2V	112	130	130
	RD	14,5	21	28		RD	32	39	48		RD	130	130	130
	MV	16	24	31		MV	36	43	55		MV	130	130	130

The reference fluid has a kinematic viscosity of 30 cSt and a density of 0,86 Kg/dm³.
For different oil viscosity please contact our Sales Department for further information.

DIRT HOLDING CAPACITY(g) ISO MTD $\Delta p = 500$ kPa (5 bar)

Type	Filter Media			
	2T	2C	2D	2V
CCH 003	1,5	2,0	2,5	3,8
CCH 152	3,0	3,8	4,2	6,2
CCH 302	10,9	14,1	15,6	21,8

The reference fluid has a kinematic viscosity of 30 cSt and a density of 0,86 Kg/dm³.
For different oil viscosity please contact our Sales Department for further information.

FILTER AREA(cm²)

Type	Filter Media	
	RD	MV
CCH 003	333	333
CCH 152	430	430
CCH 302	1455	1455