

Part number:

RE 18309-45/04.10 1/2
Replaces: RE 00171/02.07

Flow regulator, 3-way, pressure compensated, with relief

VRFC3-VS

0M.33.03 - X - Y

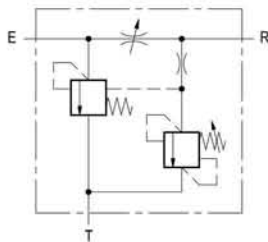
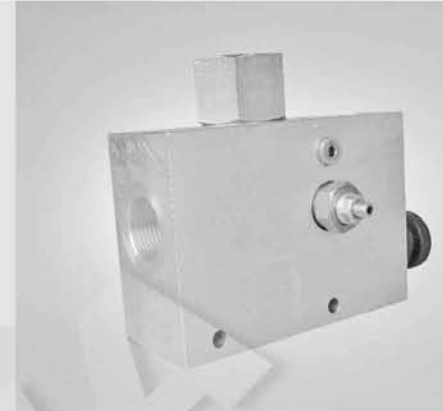

Performance

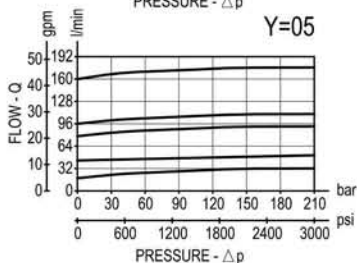
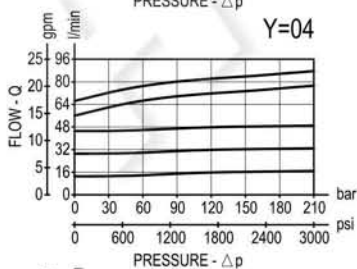
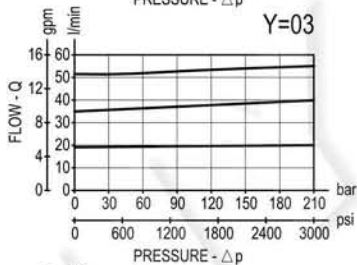
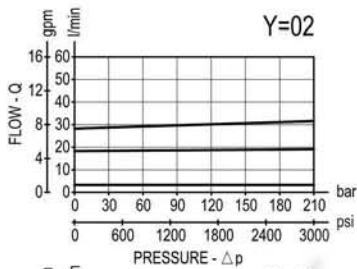

Description

A constant pressure compensated flow rate is established from E to R, while a minimum pressure differential of appr. 5 bar (70 psi) exists between the two ports. Input flow supplied to E in excess of the regulated output at R is by-passed to T. Output flow can be varied from closed to the nominal maximum rating for the valve. The valve module includes a small pilot relief cartridge which senses the pressure of the Regulated flow and diverts it to tank if the maximum allowed pressure is reached. Reverse flow from R to E is limited by the selected opening of the restrictor and is not pressure compensated. Flow from T to E or from T to R is not permitted.

Technical data

Hydraulic

Max. pressure	bar (psi)	210 (3000)
---------------	-----------	------------

Adj. relief valve: range 35-210 bar (500-3000 psi).

Standard setting: 210 bar (3000 psi)

QE = max inlet flow "E" port (see "Dimensions")

QR = max regulated flow "R" port (see "Dimensions")

Flow range adjustment : 0 - 3 turns

General

Manifold material	Aluminium
-------------------	-----------

Note: aluminium bodies are often strong enough for operating pressures exceeding 210 bar (3000 psi), depending from the fatigue life expected in the specific application. If in doubt, consult our Service Network.

Weight	see "Dimensions"
--------	------------------

Fluid temperature range	°C (°F)	between -30 (-22) and +100 (212)
-------------------------	---------	----------------------------------

Other technical data	see data sheet RE 18350-50
----------------------	----------------------------

Note: for applications outside these parameters, please consult us.

Dimensions

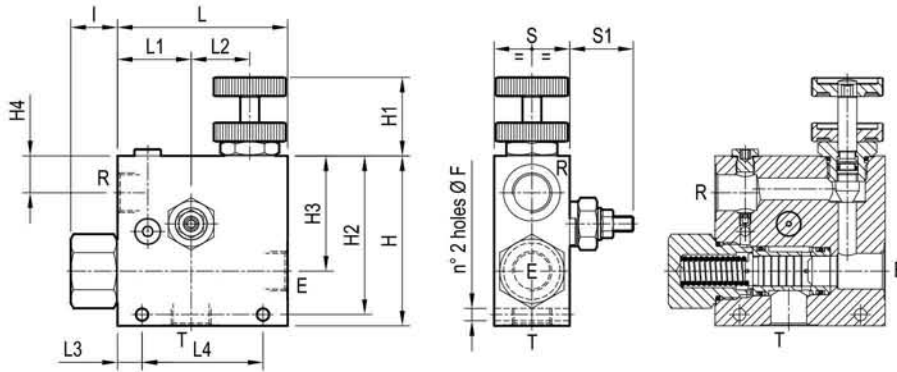

34 (1.34)	60 (2.36)	75 (2.95)	20 (0.79)	62 (2.44)	65 (2.56)	155 (6.1)	25 (0.98)	46 (1.81)	83 (3.27)	100 (3.94)	40 (1.58)	110 (4.33)	8.5 (0.34)	190 l/min 50 gpm	280 l/min 74 gpm	G 1	3.3 (7.3)
34 (1.34)	50 (1.97)	88 (3.47)	10 (0.39)	35 (1.38)	44 (1.73)	108 (4.25)	25 (0.98)	23 (0.91)	73 (2.87)	101 (3.98)	40 (1.58)	108 (4.25)	8.5 (0.34)	90 l/min 24 gpm	150 l/min 40 gpm	G 3/4	2 (4.4)
34 (1.34)	40 (1.58)	64 (2.52)	13 (0.51)	31 (1.22)	39 (1.54)	90 (3.54)	25 (0.98)	17.5 (0.69)	60 (2.36)	84 (3.31)	40 (1.58)	90 (3.54)	6.5 (0.26)	55 l/min 15 gpm	90 l/min 24 gpm	G 1/2	1.1 (2.42)
34 (1.34)	40 (1.58)	64 (2.52)	13 (0.51)	31 (1.22)	39 (1.54)	90 (3.54)	25 (0.98)	17.5 (0.69)	60 (2.36)	84 (3.31)	40 (1.58)	90 (3.54)	6.5 (0.26)	30 l/min 8 gpm	55 l/min 15 gpm	G 3/8	1.1 (2.42)
S1	S	L4	L3	L2	L1	L	I	H4	H3	H2	H1	H	F	QR	QE	Y	Weight kg (lbs)

[mm (inches)]

Ordering code

OM.33.03 | **X** | **Y**

Flow regulator,
3-way, pressure compensated
with relief

Adjustments

= 70 Handknob and locknut



= 80 Screw and locknut



= 40 Graduated handknob



Port sizes	E - R - T
= 02	G 3/8
= 03	G 1/2
= 04	G 3/4
= 05	G 1

Type	Material number
OM330370020000A	R930004260
OM330370030000A	R930004262
OM330370040000A	R930004263
OM330370050000A	R930004264
OM330380020000A	R930004266
OM330380030000A	R930004267
OM330380040000A	R930004268
OM330380050000A	R930004270

Type	Material number
OM330340020000A	R930004251
OM330340030000A	R930004252
OM330340040000A	R930004254
OM330340050000A	R930004255